

FOR OFFICIAL USE

Centre No.	Subject No.	Grade	Paper No.	Group No.	Marker's No.
------------	-------------	-------	-----------	-----------	--------------

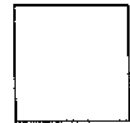

[C069/SQP118]

Total Marks

Intermediate 1 Time: 1 hour 30 minutes
Physics
Specimen Question Paper

NATIONAL
QUALIFICATIONS

Fill in these boxes and read what is printed below.

Full name of centre

Town

First name and initials

Surname

Date of birth

Day Month Year

--	--	--	--	--	--	--	--

Candidate number

--	--	--	--	--	--	--	--	--	--

Number of seat

- 1 All questions should be answered.
- 2 The questions may be answered in any order but all answers must be written clearly and legible in this book.
- 3 For questions 1–9, write down, in the space provided, the letter corresponding to the answer you think is correct. There is only **one** correct answer.
- 4 For questions 10–22, write your answer where indicated by the question or in the space provided at the end of the answer book.
- 5 If you change your mind about your answer you may score it out and replace it in the space provided at the end of the answer book.
- 6 Before leaving the examination room you must give this book to the invigilator. If you do not, you may lose all the marks for this paper.

1. Which colours of light do the coatings on a colour television screen give out when struck by electrons?
- A Red, yellow, blue
 - B Red, yellow, green
 - C Red, white, blue
 - D Red, green, blue
 - E Red, green, white

Answer

(1)

2. The block diagram below shows the parts of a television receiver. Only some of the blocks have been named.

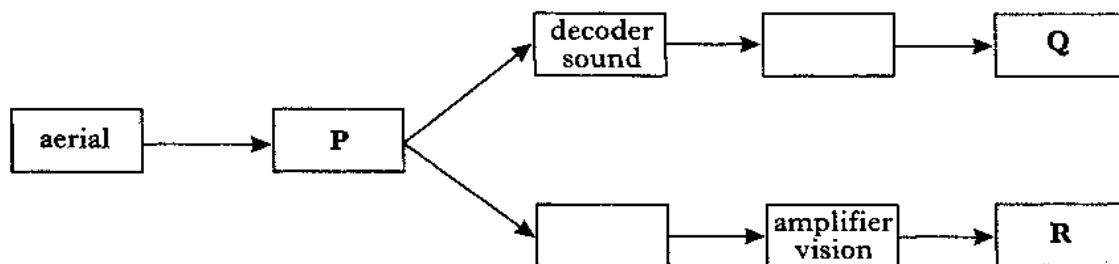

Which entry in the table identifies the parts labelled P, Q and R?

	P	Q	R
A	decoder vision	amplifier sound	tuner
B	loudspeaker	amplifier sound	decoder vision
C	decoder vision	picture tube	tuner
D	tuner	picture tube	loudspeaker
E	tuner	loudspeaker	picture tube

Answer

(1)

3. Which of the following entries matches the terminals in a 13 ampere plug with the colours of the insulation on the wires?

	Live	Neutral	Earth
A	green/yellow	blue	brown
B	blue	brown	green/yellow
C	brown	blue	green/yellow
D	brown	green/yellow	blue
E	blue	green/yellow	brown

Answer

(1)

4. Which of the following uses the most electrical energy?
- A An appliance of power 1 kilowatt used for $\frac{1}{2}$ hour
 - B An appliance of power 1 kilowatt used for 2 hours
 - C An appliance of power 2 kilowatts used for $\frac{1}{2}$ hour
 - D An appliance of power 2 kilowatts used for 1 hour
 - E An appliance of power 2 kilowatts used for 2 hours

Answer (1)

5. Which type of radiation can cause skin cancer?

- A Gamma rays
- B Ultraviolet
- C X-rays
- D Infrared
- E Visible light

Answer (1)

6. The diagram shows the path of a ray of light, X, directed at a plane mirror. Which line, A, B, C, D, or E, shows the path of the reflected ray?

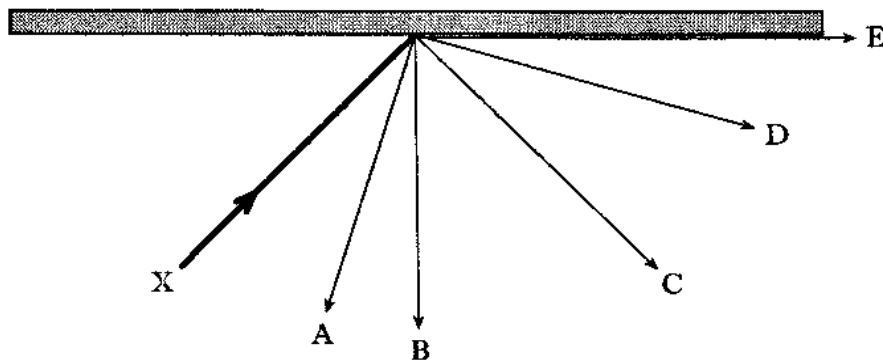

Answer (1)

7. Sound level is measured in

- A hertz
- B ohms
- C watts
- D decibels
- E metres per second.

Answer (1)

8. Which of the following lists contains only **input** devices?

- A Microphone, buzzer, LDR
- B Thermistor, LDR, switch
- C Thermistor, switch, lamp
- D Loudspeaker, LED, motor
- E Microphone, LED, loudspeaker

Answer (1)

10. (continued)

- (ii) Give one advantage of using optical fibres compared to radio waves for communication.

(1)

- (iii) A student measures the length of the optical fibre and the time taken for the light signal to travel between the transmitter and the receiver. The student then calculates the speed of light through the fibre.

Explain why this information would not give an accurate result for the speed of light through the fibre.

(2)

11. (a) A student sets up the circuit shown in figure 1.

Voltmeter V_1 gives a reading of 3 volts.

What is the reading on the voltmeter V_2 ?

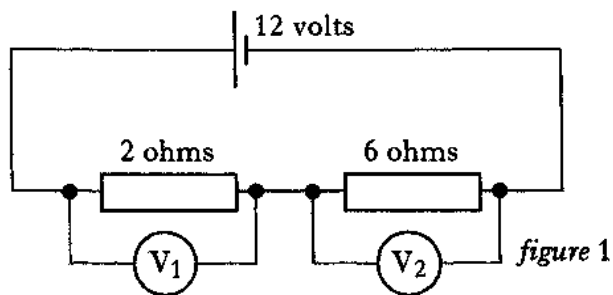

(1)

- (b) The student now sets up the circuit shown in figure 2.

Ammeter A_1 gives a reading of 6 amperes.

Ammeter A_2 gives a reading of 8 amperes.

What is the reading on the ammeter A_3 ?

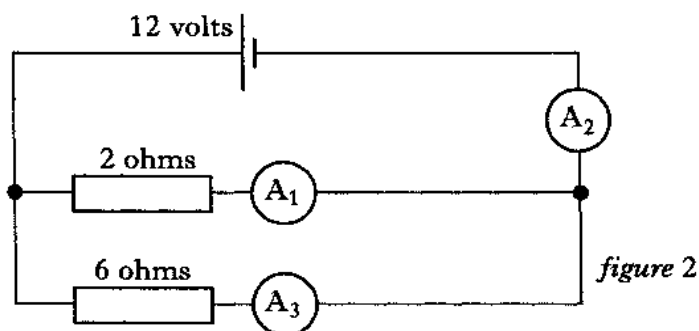

(1)

- (c) Draw the symbol for a variable resistor.

(1)

- (d) A resistor R is connected across a battery as shown in figure 3. The ammeter reading is 3 amperes.

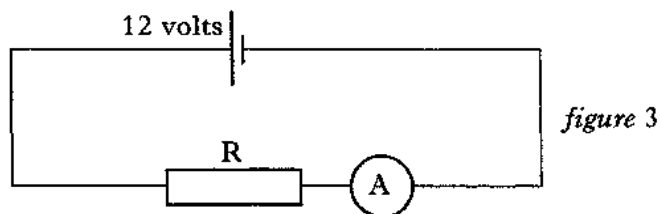

Calculate the resistance of resistor R .

(2)

12. A student constructs a continuity tester which can be used to test fuses to see if they are blown.

The fuse to be tested is inserted between the terminals marked X and Y.

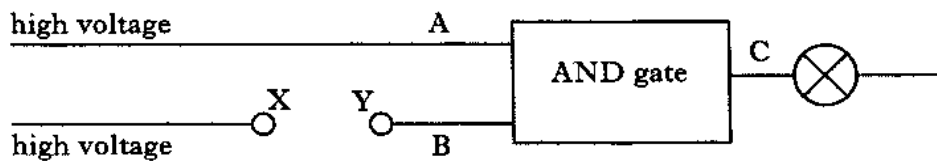

When point C is at a high voltage the lamp lights.

- (a) Draw the circuit symbol for a fuse.

(1)

- (b) Explain how the student's continuity tester can show whether a fuse is blown or not.

(3)

13. The flex of a vacuum cleaner is connected to a plug as shown.

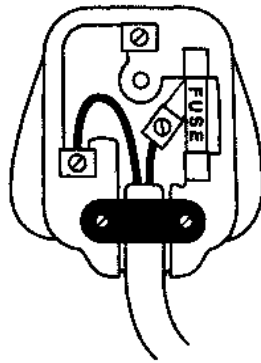

(a) Which wire is not required for the vacuum cleaner?

(1)

(b) What is the name given to appliances that only have two wires in their flexes?

(1)

(c) The vacuum cleaner is supplied with the same voltage no matter which socket it is connected to in the house.
How are the sockets connected in the household wiring?

(1)

13. (continued)

- (d) An electric fire is connected to the mains supply in a house.
The power rating of the fire is 920 watts.

A suitable fuse is required for the plug of the fire.

The following fuses are available: 3 amperes, 5 amperes and 13 amperes.

Which fuse should be fitted to the plug?

You should show a calculation to support your answer.

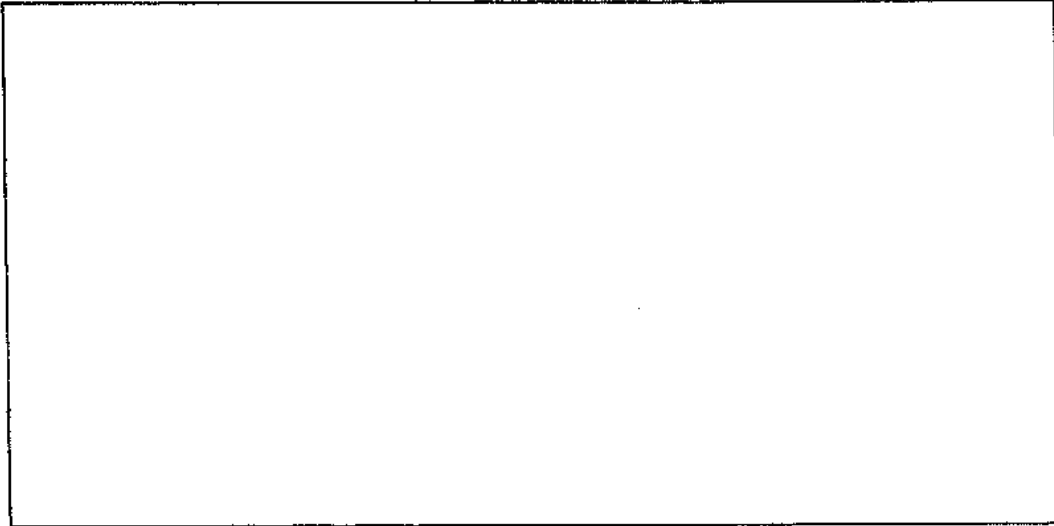
**(3)**

14. Visible light, X-rays, infrared, gamma and ultraviolet rays all have important uses.

(a) Complete the table below to match the names of these different radiations with their descriptions.

invisible can kill living cells	invisible can damage living cells	invisible detected by fluorescent material	visible produces colours of the spectrum	invisible called heat radiation
can pass through most materials	detected by photographic film			
			VISIBLE LIGHT	

(2)

(b) Figure 1 shows the apparatus which could be used to monitor the radiation given out by a radioactive source.

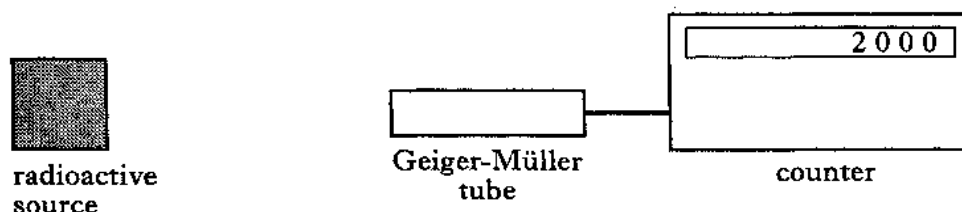

figure 1

(i) The counter is switched on for one minute and it records a reading of 2000 counts.

If this experiment is repeated at later times, what would you expect to happen to this reading?

(1)

(ii) The source is now removed. The counter is again switched on for one minute.

What will happen to the reading on the counter?

Explain your answer.

(2)

15. (a) Contact lenses are prescribed for a person who is short sighted.

Complete the figure to show the path of the rays through the eye for a person with short sight before the contact lenses are fitted.

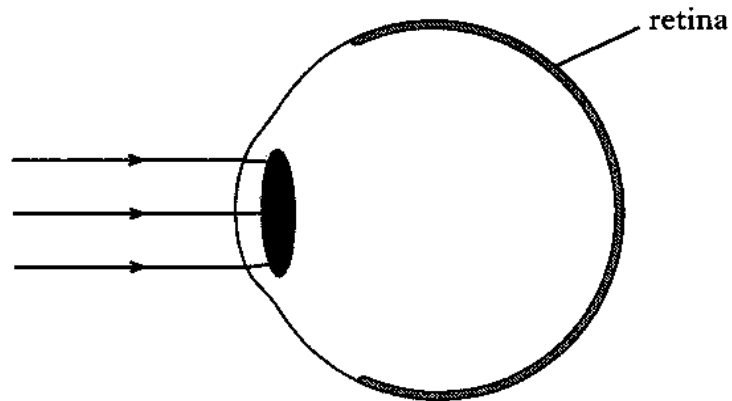

(2)

(b) Complete the table to show which type of lens should be used to correct long sight and short sight.

<i>Eye defect</i>	<i>Type of lens required</i>
Long sight	
Short sight	

(2)

16. Use information from the following passage to answer the questions below.

The living body gives out heat energy.

It is possible to detect this heat with a camera which produces a special photograph called a thermogram.

Thermograms show different coloured patches with each colour representing different temperatures. The hottest parts show up as white and the coldest parts show up as blue. The highest temperatures correspond to the shorter wavelengths of the radiation and the lower temperatures correspond to the longer wavelengths.

Diseased tissue is warmer than healthy tissue and because of this it is possible to detect areas of diseased tissue.

Another application of Physics in medicine is the use of ultrasound waves by physiotherapists to help repair damaged tissue. The ultrasound waves can be used to set up vibrations in areas of the body which are difficult or impossible to reach using normal massage treatment.

(a) What colour would diseased tissue be on a thermogram?

(1)

(b) Complete the table to show how temperature and wavelength are related in a thermogram:

<i>Temperature</i>	<i>Wavelength</i>
Low	
High	

(1)

(c) (i) What use do physiotherapists make of ultrasound waves?

(ii) What advantage do ultrasound waves have over normal massage treatment?

(2)

17. A guitarist can produce many different musical notes from a guitar.

- (a) Give **two** ways in which the guitarist can increase the frequency of the note produced.

(2)

- (b) Two different notes produced by the guitar are displayed on the screen of an oscilloscope as shown in figure 1.

Which trace represents the louder note?

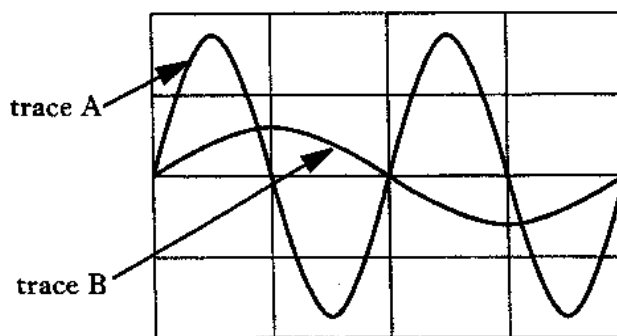

figure 1

Which trace represents the note with the higher frequency?

(2)

- (c) The guitarist uses an amplifier when performing in front of a large audience.

The input signal to the amplifier and the output signal from the amplifier are displayed on oscilloscopes.

The traces obtained are shown in figure 2.

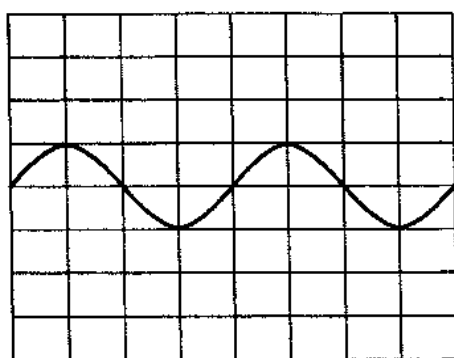

Input signal

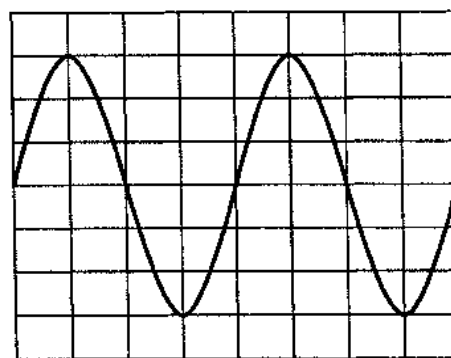

Output signal

figure 2

Both oscilloscopes have the same settings.

Calculate the voltage gain of the amplifier.

(3)

18. A form of sound wave which cannot be heard by humans has important applications in medicine and in industry.

(a) (i) What is the normal range of human hearing in hertz?

(ii) What is the name given to high frequency sounds that are above the normal range of human hearing?

(2)

(b) The speed of a sound wave travelling through air can be measured using the apparatus shown in the diagram below.

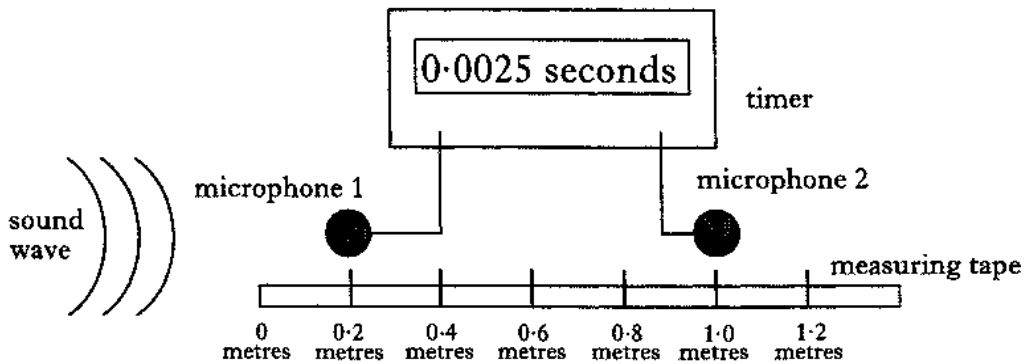

The sound wave reaches microphone 1 and starts the timer.
When the sound wave reaches microphone 2 the timer is stopped.

Use the information shown in the diagram to calculate the speed of sound through air.

(3)

19. A spacecraft is on a journey in outer space.

- (a) A spacesuit on board the craft has a mass of 40 kilograms.
Calculate the weight of this spacesuit on Earth.

(2)

- (b) During part of the flight the spacecraft travels a distance of 800 metres in a time of 2 seconds.
Calculate the average speed of the spacecraft during this time.

(2)

- (c) The spacecraft has four identical rockets A, B, C and D.
When rockets A and B only are firing, the spacecraft moves to the right.
When rockets C and D only are firing, the spacecraft moves to the left.

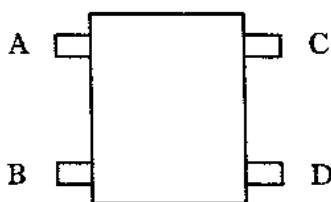

figure 1

Fill in each line in the table saying whether the forces acting on the spacecraft are **balanced** or **not balanced**.

<i>Condition of rockets</i>	<i>Forces on spacecraft</i>
A and B on C and D on	
A and B off C and D off	
A and B on C and D off	

(3)

19. (continued)

- (d) The astronauts on board the spacecraft communicate with Earth using radio waves.

The spacecraft is fitted with a dish aerial for both transmitting and receiving signals.

The astronauts have headsets for communication as shown in figure 2.



figure 2

- (i) Complete the diagram to show how the dish aerial can make an incoming signal stronger.

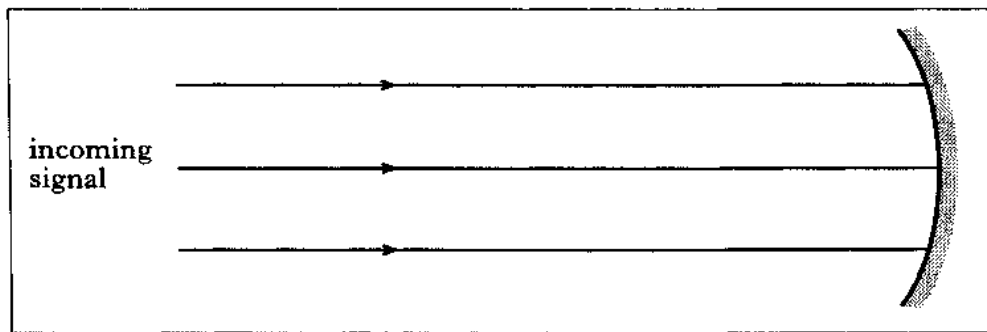

(2)

- (ii) What device is contained in the mouthpiece of the headset?

(1)

- (iii) The earpiece in the headset contains a loudspeaker.
What energy change takes place in the earpiece?

(1)

- (iv) The signal received in the astronaut's earpiece can be made stronger.
What device is used to make the signal stronger?

(1)

20. (a) Figure 1 shows the path taken by a golf ball after it has been struck by a club.



- (i) Without changing the club in any way, give **two** factors which would increase the speed of the ball as it leaves the club.

(2)

- (ii) The golf ball hits the ground and rebounds to a new height as shown in figure 2.

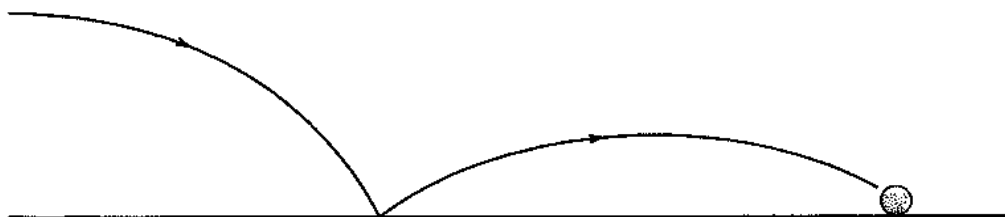

figure 2

Give **two** factors which affect the height to which the golf ball rebounds.

(2)

- (b) A student uses a putter to hit a golf ball across the floor of a laboratory. Describe how you could measure the instantaneous speed of the ball as it leaves the club.

(3)

21. (a) A logic gate has the symbol shown in figure 1.

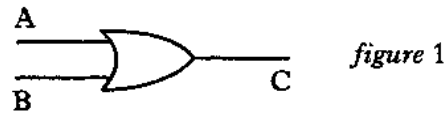

(i) Name this logic gate.

(1)

(ii) The table shows the possible input levels to the gate. Complete the table to show the correct output levels.

A	B	C
0	0	
0	1	
1	0	
1	1	

(1)

(b) Two different logic gates are built into a circuit as shown in figure 2.

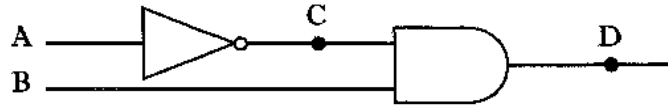

figure 2

Complete the table for the logic diagram shown in figure 2.

A	B	C	D
0	0		
0	1		
1	0		
1	1		

(2)

22. (a) The electronic circuit used in a calculator is represented by the block diagram shown in figure 1.

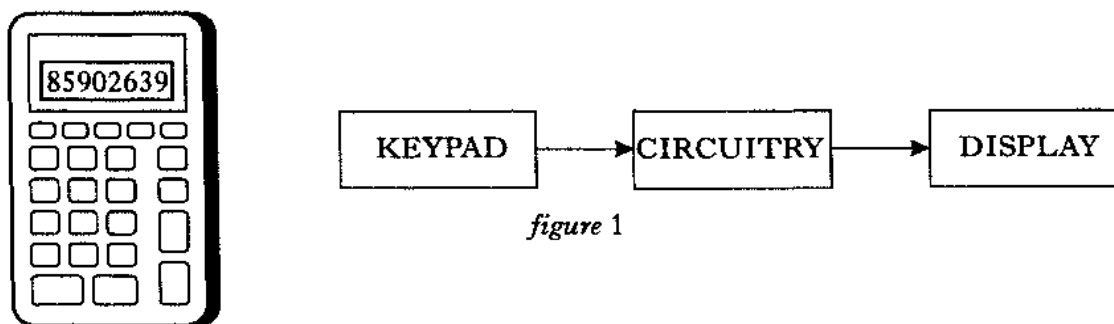

figure 1

Which of the three blocks represents the output device of the calculator?

(1)

- (b) The graphs in figure 2 show three ways in which resistance could change with brightness.
Only one of these graphs is possible for a light dependent resistor (LDR).

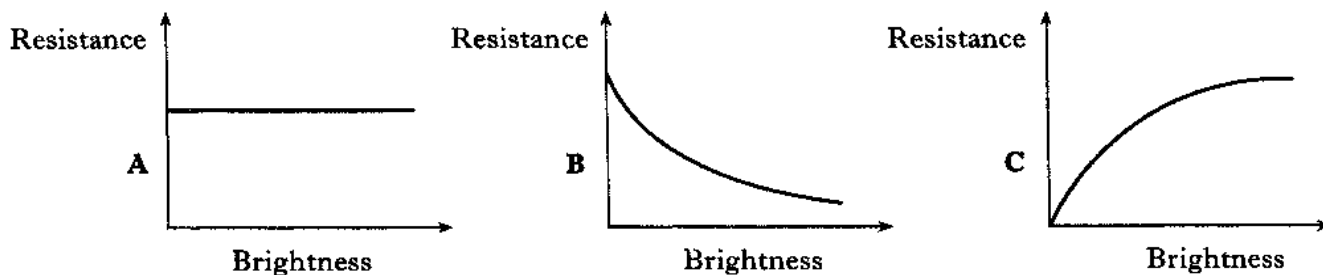

figure 2

Which graph, **A**, **B**, or **C**, shows how the resistance of the LDR varies with brightness?

(1)

22. (continued)

(c) A greenhouse is fitted with heaters and lights.

The lights should always come on at night.

The heaters can be switched on by the owner if the temperature in the greenhouse falls below a certain value.

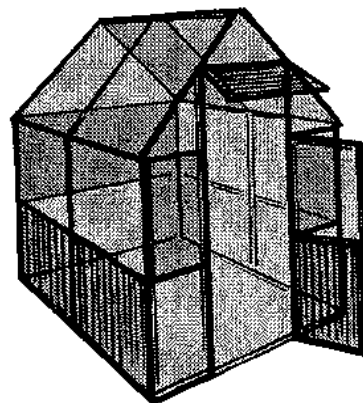

Complete figure 3 using an OR gate and two NOT gates to show the design of a circuit which will sound an alarm buzzer to warn the owner of the greenhouse if either the lights fail or the heaters need switching on.



figure 3

(3)

[END OF QUESTION PAPER]

Marks

YOU MAY USE THE SPACE ON THIS PAGE TO REWRITE ANY ANSWER YOU HAVE DECIDED TO CHANGE IN THE MAIN PART OF THE ANSWER BOOKLET. TAKE CARE TO WRITE IN CAREFULLY THE APPROPRIATE QUESTION NUMBER.

--

YOU MAY USE THE SPACE ON THIS PAGE TO REWRITE ANY ANSWER YOU HAVE DECIDED TO CHANGE IN THE MAIN PART OF THE ANSWER BOOKLET. TAKE CARE TO WRITE IN CAREFULLY THE APPROPRIATE QUESTION NUMBER.

--

[C069/SQP118]

Intermediate 1
Physics
Specimen Marking Instructions

NATIONAL
QUALIFICATIONS

General advice to markers

The general comments given below should be considered at all times during the marking process.

- 1 Where a question requires a numerical response, the part marks shown in the marking scheme are for use in marking partially correct answers.
- 2 Unless a question requires evidence of working to be shown explicitly, full marks should be awarded for a correct answer on its own.
- 3 Where 1 mark is shown for the final answer to a numerical problem, a half mark should be deducted for an incorrect or missing unit unless otherwise stated in the marking scheme.
- 4 Deduct half a mark if an answer is wrong because of an arithmetical slip.
- 5 No further marks should be awarded for a part-question after the application of a wrong physics principle unless specifically allowed for in the marking scheme.
- 6 Where a relationship is written down by the candidate in a “triangle” format and then not used or used incorrectly, the mark which is allocated by the scheme to recalling the relationship should not be awarded.
- 7 Full marks should be given where the response required by the question is conveyed correctly by a diagram.
- 8 Where a wrong numerical answer (already penalised) is carried forward to another part of the question, no further penalty is incurred provided that it is used correctly.

1. D 2. E 3. C 4. E 5. B 6. C 7. D 8. B 9. B
1 mark for each

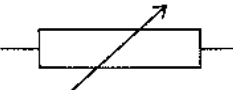
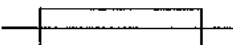
10. (a) 300 000 000 metres per second {1} 1
- (b) loudspeaker {1/2}
 amplifier {1/2}
 aerial {1/2}
 tuner {1/2} 2
- (c) (i) radio signal {1} 1
- (ii) less interference {1} 1
 (or other suitable response)
- (iii) the distance travelled by the light is longer {1}
 than the length of the fibre {1} 2
11. (a) 9 volts {1} 1
- (b) 2 amperes {1} 1
- (c)  {1} 1
- (d) resistance = $\frac{\text{voltage}}{\text{current}} = \frac{12}{3} = 4 \text{ ohms}$ {1} 2
12. (a)  {1} 1
- (b) complete fuse: 2 high inputs to gate (or B high) {1}
 high output (or C high) {1}
 lamp lights {1} 3
- or** blown fuse: 1 high input to gate (or B low) {1}
 low output (or C low) {1}
 lamp unlit {1}
13. (a) the earth wire {1} 1
- (b) double insulated {1} 1
- (c) parallel {1} 1
- (d) current = $\frac{\text{power}}{\text{voltage}} = \frac{920}{230} = 4 \text{ amperes}$ {1}
- chosen fuse = 5 amperes {1} 3
- chosen fuse must be consistent with value obtained for current to obtain final mark

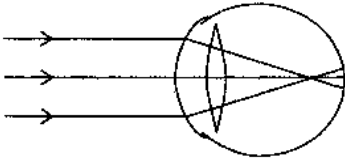
14. (a)
- | | | | | | |
|------------|-----------|-------------------|--|---------------|---|
| gamma rays | X-rays | ultra-violet rays | | infrared rays | |
| $\{1/2\}$ | $\{1/2\}$ | $\{1/2\}$ | | $\{1/2\}$ | 2 |
- (b) (i) reading will fall (below 2000) as time goes on $\{1\}$ 1
- (ii) reading will fall to a low value (**not** zero) because it is now detecting background radiation $\{1\}$ 2
15. (a)
- 
- for rays coming to focus $\{1\}$
- for focus in front of retina $\{1\}$ 2
- (b) long sight → convex (converging) lens $\{1\}$
- short sight → concave (diverging) lens $\{1\}$ 2
16. (a) white $\{1\}$ 1
- (b)
- | | |
|---------|-----------|
| longer | $\{1/2\}$ |
| shorter | $\{1/2\}$ |
- 1
- (c) (i) help repair damaged tissue $\{1\}$
- (ii) to get to parts of the body impossible to reach using normal massage $\{1\}$ 2
- 17 (a) increase the tension in the string $\{1\}$
- shorten the length of the string $\{1\}$ 2
- (b) trace A is louder $\{1\}$
- trace A has a higher frequency $\{1\}$ 2
- (c) voltage gain
- $$= \frac{\text{output voltage}}{\text{input voltage}} = \frac{3}{1} = 3$$
- $\{1/2\}$ $\{1\}$ $\{1/2\}$ 3
- deduct $1/2$ mark for any units in answer

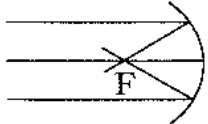
18. (a) (i) 20 hertz to 20 000 hertz {1}
- (ii) ultrasound {1} 2
- (b) distance between microphones = 0.8 metres {1}
- $$\text{speed} = \frac{\text{distance} \left\{ \frac{1}{2} \right\}}{\text{time}} = \frac{0.8 \left\{ \frac{1}{2} \right\}}{0.0025} = 320 \text{ metres per second } \{1\}$$
- 3
19. (a) weight = mass $\times 10 \left\{ \frac{1}{2} \right\} = 40 \times 10 \left\{ \frac{1}{2} \right\} = 400$ newtons {1} 2
- (b) $\text{speed} = \frac{\text{distance} \left\{ \frac{1}{2} \right\}}{\text{time}} = \frac{800 \left\{ \frac{1}{2} \right\}}{2} = 400$ metres per second {1} 2
- (c) balanced {1}
- balanced {1}
- not balanced {1} 3
- (d) (i) 
- correct reflections {1}
- clearly marked focus {1} 2
- (ii) microphone {1} 1
- (iii) electrical \rightarrow sound {1} 1
- (iv) amplifier {1} 1
20. (a) (i) size of the force of club on ball {1}
- time of contact between club and ball {1} 2
- (or other acceptable response)
- (ii) speed with which the ball hits the ground {1}
- type of surface (of ball, ground or both) {1} 2
- (or other acceptable response)
- (b) use light gate {1}
- measure diameter of ball $\left\{ \frac{1}{2} \right\}$
- record time on clock $\left\{ \frac{1}{2} \right\}$
- use speed = distance/time {1} 3
- (award first mark for a diagram showing light gate)

21. (a) (i) OR {1} 1

(ii)

C
0
1
1
1

{1} 1

(b)

C	D
1	0
1	1
0	0
0	0

{1} {1}

2

22. (a) display {1} 1

(b) B {1} 1

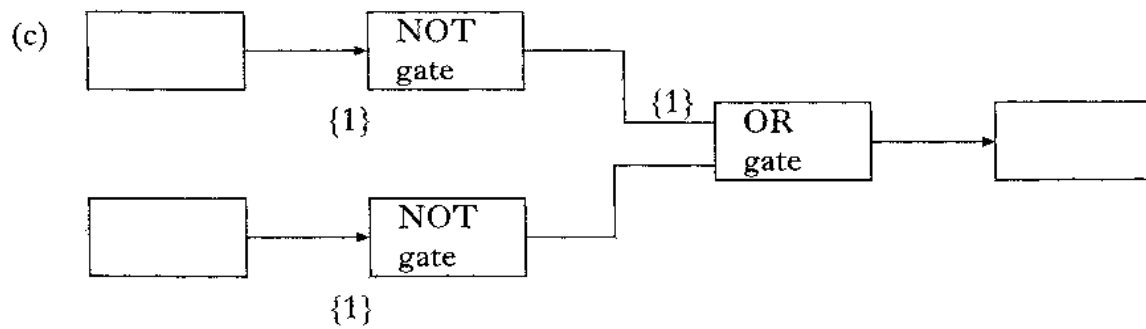

3

[END OF MARKING INSTRUCTIONS]

Int 1	OUTCOME 1				OUTCOMES 2 & 3			
Question	Quantities Units Symbols	Relationships	Methods	Facts	2 a	2 b 3 d	2 c 3 e	3 b
1				1				
2				1				
3				1				
4						1		
5				1				
6			1					
7	1							
8				1				
9				1				
10 (a)	1							
(b)					2			
(c) (i)							1	
(ii)				1				
(iii)							2	
11 (a)		1						
(b)		1						
(c)	1							
(d)		2						
12 (a)	1							
(b)							3	
13 (a)								
(b)				1			1	
(c)				1				
(d)						3		
14 (a)					2			
(b) (i)							1	
(b) (ii)							2	
15 (a)			2					
(b)				2				
16 (a)								
(b)					1		1	
(c)							2	
17 (a)								
(b)				2				
(c)					2		3	
18 (a)								
(b)				2			3	

Int 1	OUTCOME 1				OUTCOMES 2 & 3			
Question	Quantities Units Symbols	Relationships	Methods	Facts	2 a	2 b 3 d	2 c 3 e	3 b
19 (a) (b) (c) (d) (i) (ii) (iii) (iv)		2 2		2 1 1 1			3	
20 (a) (i) (ii) (b)				2 2				3
21 (a) (i) (ii) (b)	1			1			2	
22 (a) (b) (c)				1			1 3	
Totals	5	8	5	24	7	10	22	3
	42				42			

MARKS ANALYSIS INT 1 EXEMPLAR COURSE ASSESSMENT

	Outcome 1	Outcomes 2 and 3	Total
Telecom	9	5	14
Electricity	9	6	15
Radiations	6	7	13
Sound and music	5	10	15
Movement	8	6	14
Electronics	5	8	13
Totals	42	42	84

NATIONAL COURSE SPECIFICATION PHYSICS (INTERMEDIATE 1)

Details of the instrument for external assessment

The instrument of assessment will be an externally set question paper of 1.5 hours duration. The question paper will sample the Content Statements of all six component units. The question paper will consist of a mixture of objective questions and questions requiring: a short answer (a few words); a response in the form of a numerical calculation; a restricted response (a few sentences or a paragraph). Candidates will be expected to answer all of the questions in the paper.

There will be a total of 84 marks for the paper.

Approximately 42 marks will be allocated to questions which require candidates to demonstrate achievement of a sample of the performance criteria associated with Outcome 1 for the six component units.

Approximately 42 marks will be allocated to questions which require candidates to:

- demonstrate achievement of a sample of the performance criteria associated with Outcome 2 and Outcome 3 for the six component units;
- integrate knowledge and understanding, problem solving and analytical skills acquired through study of the component units;
- apply knowledge and understanding to solve problems set in contexts which are less familiar than those associated with a study of the component units.

A summary of the breakdown of the marks allocation across the outcomes and component units is as follows:

	Outcome 1	Outcomes 2 and 3	Total
Mark allocation for whole paper	42 ± 4	42 ± 4	84
Each component unit (20h)	7 ± 3	7 ± 3	14 ± 4