

[C069/SQP031]

**Higher
Physics**
Specimen Question Paper

Time: 2 hours 30 minutes

**NATIONAL
QUALIFICATIONS**

Read Carefully

- 1 All questions should be attempted.

Section A (questions 1 to 20)

- 2 Check that the answer sheet is for Higher Physics (Section A).
- 3 Answer the questions numbered 1 to 20 on the answer sheet provided.
- 4 Fill in the details required on the answer sheet.
- 5 Rough working, if required, should be done only on this question paper, or on the first two pages of the answer book provided—**not** on the answer sheet.
- 6 For each of the questions 1 to 20 there is only **one** correct answer and each is worth 1 mark.
- 7 Instructions as to how to record your answers to questions 1–20 are given on page three.

Section B (questions 21 to 29)

- 8 Answer questions numbered 21 to 29 in the answer book provided.
- 9 Fill in the details on the front of the answer book.
- 10 Enter the question number clearly in the margin of the answer book beside each of your answers to questions 21 to 29.
- 11 Care should be taken **not** to give an unreasonable number of significant figures in the final answers to calculations.

DATA SHEET
COMMON PHYSICAL QUANTITIES

<i>Quantity</i>	<i>Symbol</i>	<i>Value</i>	<i>Quantity</i>	<i>Symbol</i>	<i>Value</i>
Speed of light in vacuum	c	$3.00 \times 10^8 \text{ m s}^{-1}$	Mass of electron	m_e	$9.11 \times 10^{-31} \text{ kg}$
Charge on electron	e	$-1.60 \times 10^{-19} \text{ C}$	Mass of neutron	m_n	$1.675 \times 10^{-27} \text{ kg}$
Gravitational acceleration	g	9.8 m s^{-2}	Mass of proton	m_p	$1.673 \times 10^{-27} \text{ kg}$
Planck's constant	h	$6.63 \times 10^{-34} \text{ J s}$			

REFRACTIVE INDICES

The refractive indices refer to sodium light of wavelength 589 nm and to substances at a temperature of 273 K.

<i>Substance</i>	<i>Refractive index</i>	<i>Substance</i>	<i>Refractive index</i>
Diamond	2.42	Water	1.33
Crown glass	1.50	Air	1.00

SPECTRAL LINES

<i>Element</i>	<i>Wavelength/nm</i>	<i>Colour</i>	<i>Element</i>	<i>Wavelength/nm</i>	<i>Colour</i>
Hydrogen	656	Red	Cadmium	644	Red
	486	Blue-green		509	Green
	434	Blue-violet		480	Blue
	410	Violet	<i>Lasers</i>		
	397	Ultraviolet	<i>Element</i>	<i>Wavelength/nm</i>	<i>Colour</i>
	389	Ultraviolet	Carbon dioxide	9550 } 10590 }	Infrared
Sodium	589	Yellow	Helium-neon	633	Red

PROPERTIES OF SELECTED MATERIALS

<i>Substance</i>	<i>Density/ kg m⁻³</i>	<i>Melting Point/ K</i>	<i>Boiling Point/ K</i>
Aluminium	2.70×10^3	933	2623
Copper	8.96×10^3	1357	2853
Ice	9.20×10^2	273
Sea Water	1.02×10^3	264	377
Water	1.00×10^3	273	373
Air	1.29
Hydrogen	9.0×10^{-2}	14	20

The gas densities refer to a temperature of 273 K and a pressure of $1.01 \times 10^5 \text{ Pa}$.

SECTION A

For questions 1 to 20 in this section of the paper, an answer is recorded on the answer sheet by indicating the choice A, B, C, D or E by a stroke made in ink in the appropriate box of the answer sheet—see the example below.

EXAMPLE

The energy unit measured by the electricity meter in your home is the

- A ampere
- B kilowatt-hour
- C watt
- D coulomb
- E volt.

The correct answer to the question is B—kilowatt-hour. Record your answer by drawing a heavy vertical line joining the two dots in the appropriate box on your answer sheet in the column of boxes headed B. The entry on your answer sheet would now look like this:

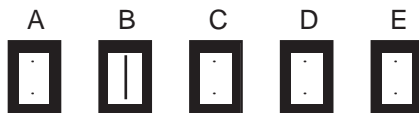

If after you have recorded your answer you decide that you have made an error and wish to make a change, you should cancel the original answer and put a vertical stroke in the box you now consider to be correct. Thus, if you want to change an answer D to an answer B, your answer sheet would look like this:

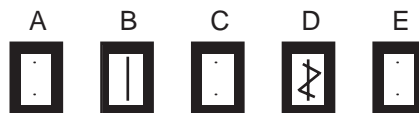

If you want to change back to an answer which has already been scored out, you should enter a tick (✓) to the RIGHT of the box of your choice, thus:



SECTION A

Answer questions 1–20 on the answer sheet.

1. A student sets up the apparatus in the diagram to measure the average acceleration of a model car as it travels between P and Q.

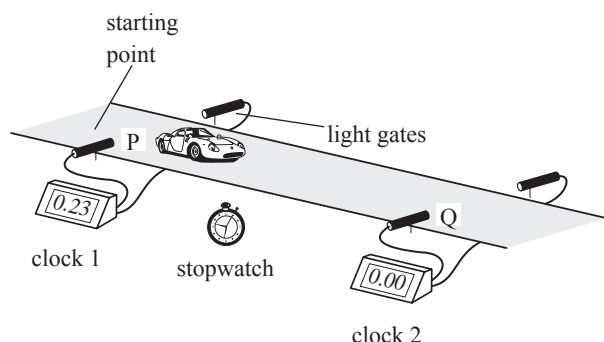

For one run, the following measurements were recorded along with their estimated uncertainty.

clock 1 reading	=	0.23 s ± 0.01 s
clock 2 reading	=	0.12 s ± 0.01 s
stopwatch reading	=	0.95 s ± 0.20 s
length of car	=	0.050 m ± 0.002 m
distance PQ	=	0.30 m ± 0.01 m

The measurement which gives the largest percentage uncertainty is the

- A reading on clock 1
 - B reading on clock 2
 - C reading on the stopwatch
 - D length of the car
 - E distance PQ.
2. Which of the rows in the following table is correct?

	<i>Scalar</i>	<i>Vector</i>
A	weight	force
B	force	mass
C	mass	distance
D	distance	momentum
E	momentum	time

3. An object is projected with a velocity V at an angle θ with the horizontal.

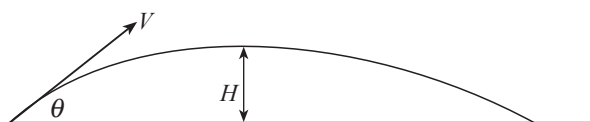

At the point of maximum height H reached by the object, the vertical acceleration and the vertical and horizontal velocities are given by

	<i>Vertical acceleration</i>	<i>Vertical velocity</i>	<i>Horizontal velocity</i>
A	g	0	$V \sin \theta$
B	0	$V \cos \theta$	$V \sin \theta$
C	0	0	$V \cos \theta$
D	0	$V \sin \theta$	0
E	g	0	$V \cos \theta$

4. An inelastic collision takes place between a moving object and a stationary object. Both objects have the same mass. In this situation, which of the following quantities is/are conserved for this system?

- I Momentum
- II Total energy
- III Kinetic energy

- A III only
- B I and II only
- C I and III only
- D II and III only
- E I, II and III

5. The diagram shows two trolleys X and Y about to collide. The momentum of each trolley before impact is given.



After the collision, the trolleys travel in opposite directions.

The magnitude of the momentum of trolley X is 2 kg m s^{-1} .

What is the corresponding magnitude of the momentum of trolley Y in kg m s^{-1} ?

- A 6
 B 8
 C 10
 D 30
 E 34
6. A motorcycle safety helmet has a soft, thick, inner lining which is compressed on impact with the skull. This design protects the skull because it
- A decreases the impulse applied to the skull
 B increases the time of impact with the skull
 C decreases the time of impact with the skull
 D decreases the change in momentum of the skull
 E increases the change in momentum of the skull.

7. A container of cross-sectional area A contains a liquid of density ρ .

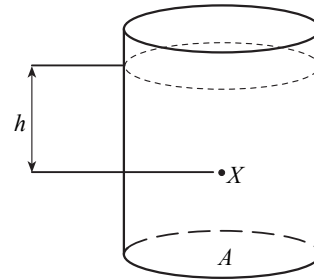

At point X, a distance h below the surface, the pressure due to the liquid is

- A $\rho g/A$
 B ρh
 C hg/A
 D $\rho h/A$
 E ρhg .
8. The diagram shows an 8 V supply connected to two lamps. The supply has negligible internal resistance.

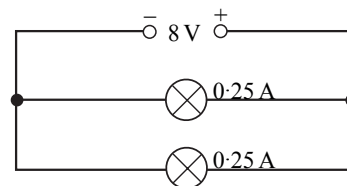

In 16 s, the total electrical energy converted in the two lamps is

- A 2 J
 B 4 J
 C 32 J
 D 48 J
 E 64 J.

9. The diagram shows a circuit used to determine the e.m.f. E and the internal resistance r of a cell.

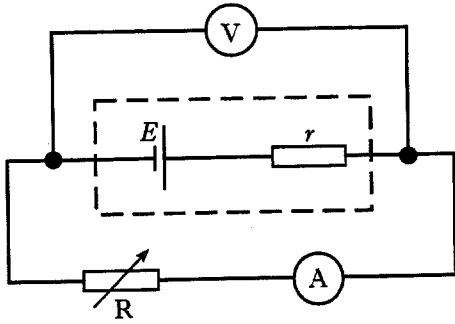

Which graph correctly shows how the potential difference V across the terminals of the cell varies with the current I in the circuit?

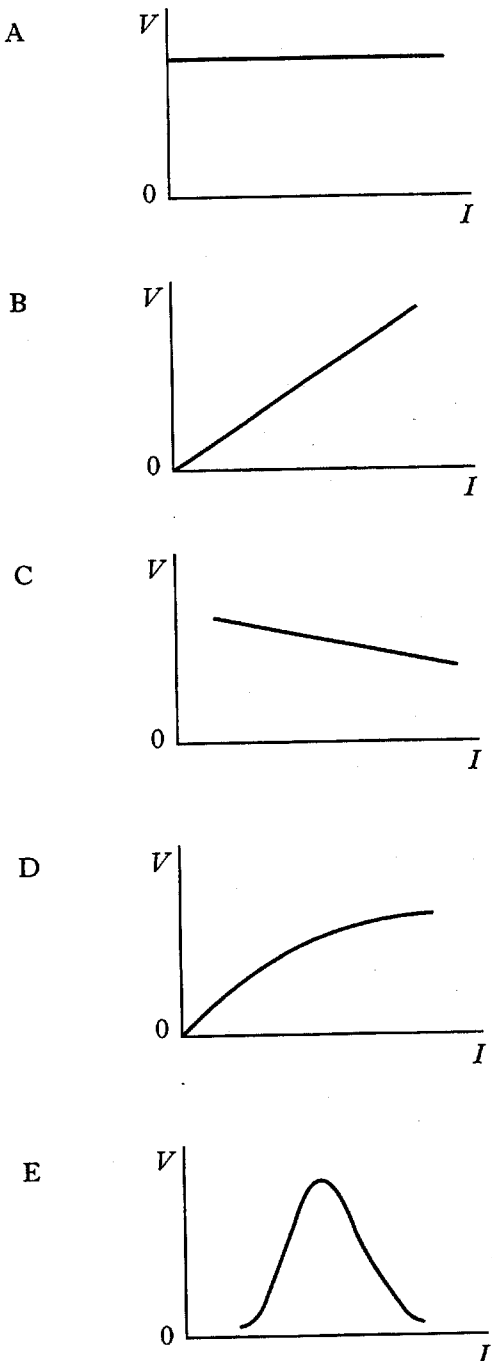

10. The graph represents a sinusoidal alternating voltage.

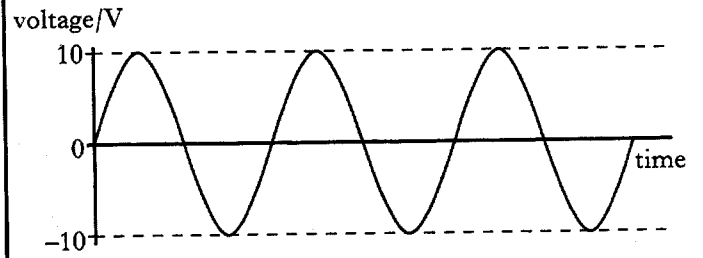

The r.m.s. (root mean square) voltage is

- A 5 V
 B $\frac{10}{\sqrt{2}}$ V
 C 10 V
 D $10\sqrt{2}$ V
 E 20 V.

11. A resistor and an ammeter are connected to a signal generator as shown below.

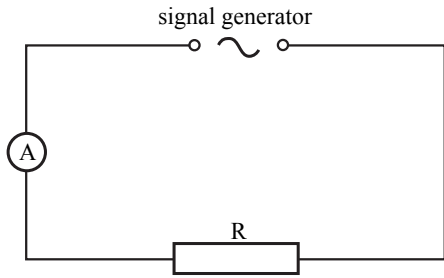

The signal generator has an output voltage of constant amplitude and variable frequency.

Which of the following graphs shows the correct relationship between the current I in the resistor and the frequency f of the output voltage of the signal generator?

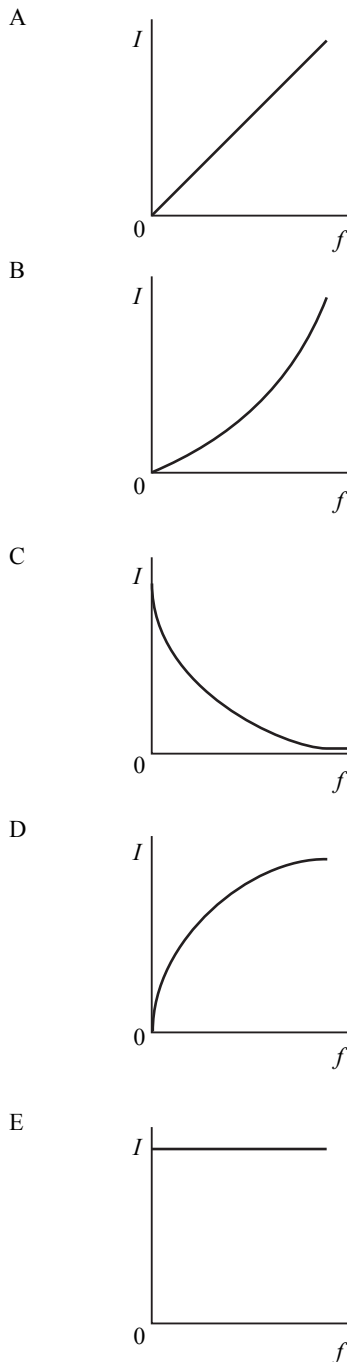

12. An ideal operational amplifier is connected as shown.

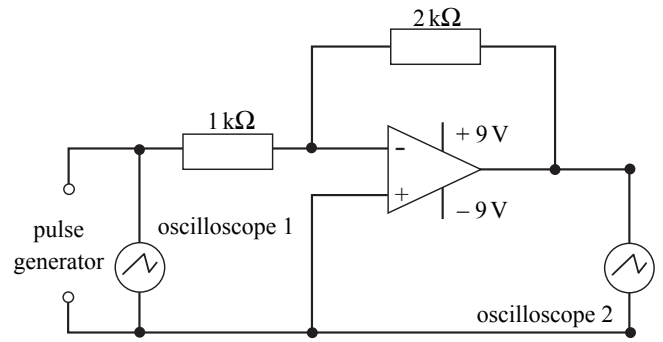

Oscilloscope 1 displays the following input signal.

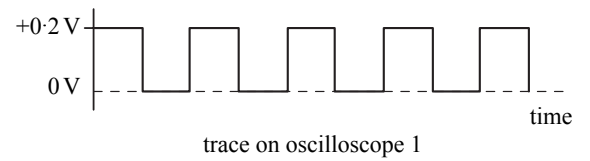

For this input signal, which output signal would be displayed by oscilloscope 2?

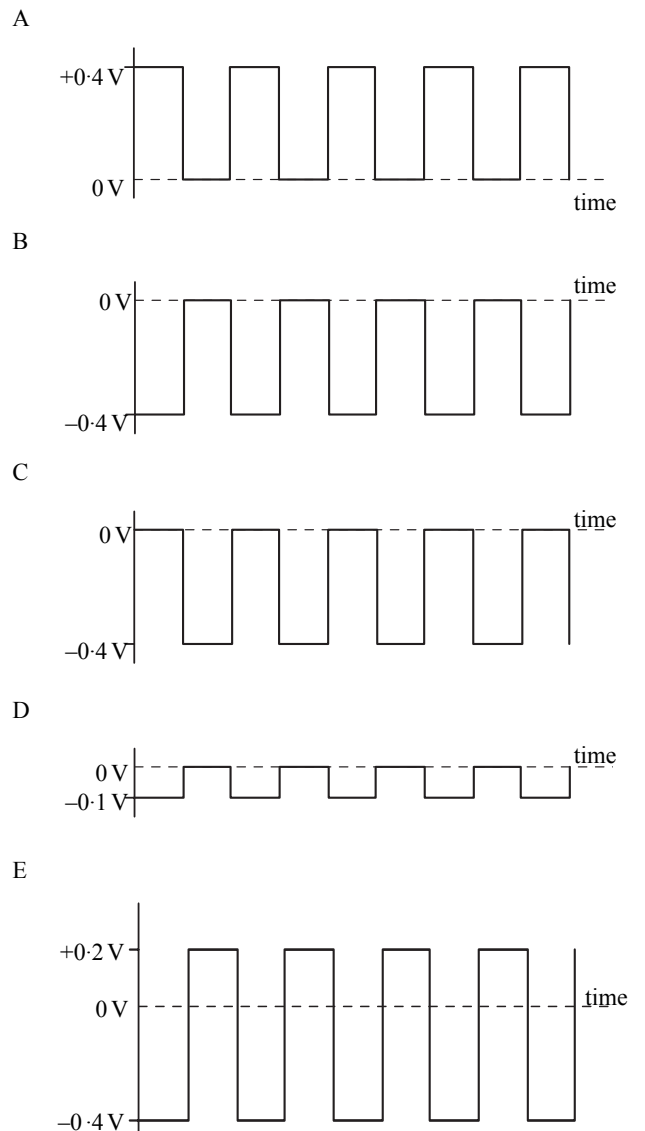

13. Two identical loudspeakers are connected to a signal generator as shown below.

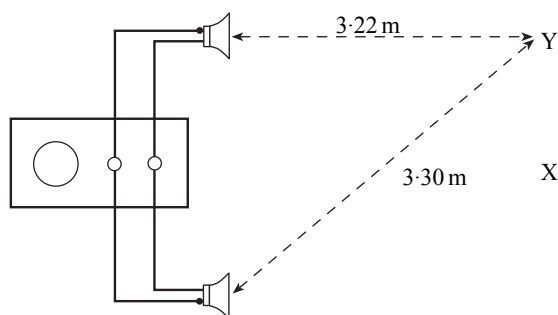

A microphone at X detects a maximum of intensity of sound.

When the microphone is moved slowly in the direction XY, it detects the first minimum of intensity of sound at Y.

The wavelength of the sound emitted from the loudspeakers is

- A 0.08 m
 B 0.16 m
 C 0.32 m
 D 0.80 m
 E 1.60 m.
14. Light of frequency 5×10^{14} Hz passes from air into glass.

The refractive index of the glass for this light is 1.5.

The speed of light in air is $3 \times 10^8 \text{ m s}^{-1}$.

What is the wavelength of this light in the glass?

- A 4.0×10^{-7} m
 B 6.0×10^{-7} m
 C 9.0×10^{-7} m
 D 1.0×10^{23} m
 E 1.5×10^{23} m

15. A space probe is positioned 3×10^{11} m from the Sun. It needs solar panels with an area of 4 m^2 to absorb energy from the Sun to enable all the systems of the probe to operate normally.

The space probe is to be repositioned at a distance of 6×10^{11} m from the Sun. What area of solar panels would now be needed to enable the probe's systems to operate normally?

- A 1 m^2
 B 2 m^2
 C 4 m^2
 D 8 m^2
 E 16 m^2

16. The diagram represents four possible energy levels of an atom.

Electrons can make transitions between the levels.

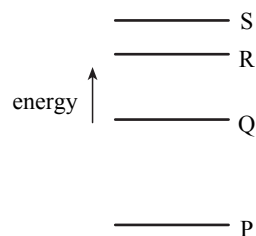

Which transition involves the greatest energy change and which transition produces radiation of the longest wavelength?

	<i>Transition with greatest energy change</i>	<i>Transition with longest wavelength</i>
A	QP	SR
B	SP	SP
C	QP	SP
D	SP	SR
E	SR	SP

17. The diagram shows the line spectrum from a hot gas. Lines X, Y and Z are associated with different electron transitions within an atom of the gas.

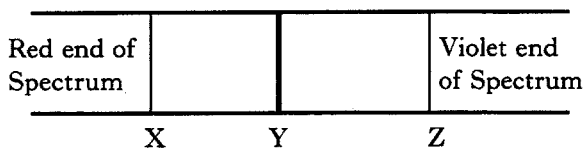

Which of the following reasons can account for the line Y appearing much brighter than lines X and Z?

- A Light causing line Y has the longest wavelength.
 - B Light causing line Y has the highest frequency.
 - C Light causing line Y originates in the hottest part of the gas.
 - D Light causing line Y is the result of electrons making a much larger transition than those responsible for lines X and Z.
 - E Light causing line Y is the result of more electrons making that particular transition than either of the other two lines.
18. Which of the following statements is/are true?

- I In a light emitting diode, positive and negative charge carriers recombine to emit light.
- II In a p-n junction diode, the majority charge carriers in the p-type material are electrons.
- III In a photodiode, electron-hole pairs are produced by the action of light.

- A I only
- B I and II only
- C I and III only
- D II and III only
- E I, II and III

19. In a laser, a photon is emitted when an electron makes a transition from a higher energy level to a lower one, as shown below.

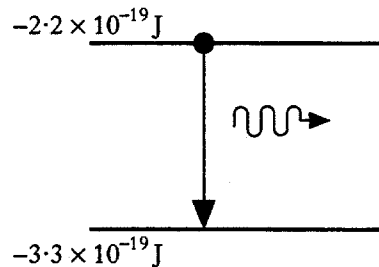

The energy in each pulse of light from the laser is 10 J. How many photons are there in each pulse?

- A $\frac{10}{5.5 \times 10^{-19}}$
- B $\frac{10}{(1.1 + 1.6) \times 10^{-19}}$
- C $\frac{10}{3.3 \times 10^{-19}}$
- D $\frac{10}{2.2 \times 10^{-19}}$
- E $\frac{10}{1.1 \times 10^{-19}}$

20. Two materials X and Y are joined together and used as an absorber for a source of gamma rays.

X has a half-value thickness of 2 cm for the gamma rays.

Y has a half-value thickness of 4 cm for the gamma rays.

The intensity of the gamma rays at the left side of the absorber is I .

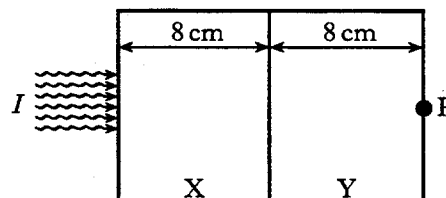

The intensity of the gamma rays at point P, on the right side of the absorber is

- A $I/8$
- B $I/16$
- C $I/32$
- D $I/64$
- E $I/128$.

SECTION B

Write your answers to questions 21 to 29 in the answer book.

Marks

21. The diagram below represents a catapult about to launch a small steel ball horizontally. The mass of the ball is 0.10 kg.

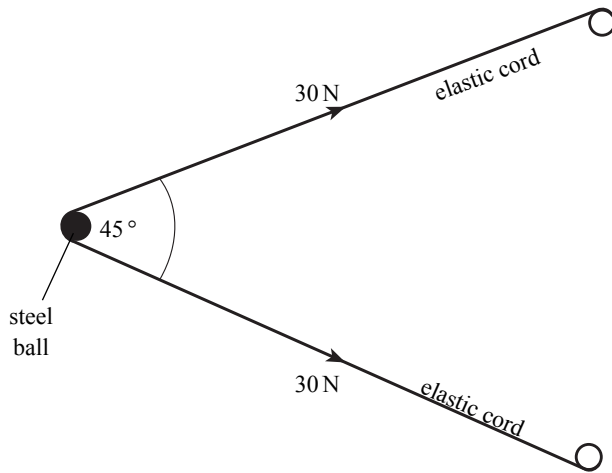

- (a) Calculate
- (i) the size of the resultant force exerted by the catapult on the steel ball
 - (ii) the initial acceleration of the steel ball in the horizontal direction.
- (b) The steel ball is aimed at the centre of a target which is 6.0 m away. The ball leaves the catapult travelling at 34 m s^{-1} in a horizontal direction.

4

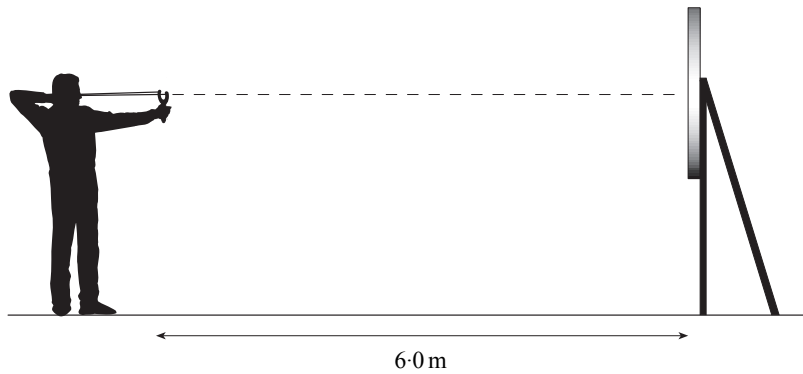

The effect of air friction may be neglected.

The ball hits the target below the centre.

Calculate the distance between the centre of the target and the point of impact.

3

(7)

22. A girl is playing with her sledge on a snow covered slope.
The girl is pulled up to the top of the slope by her father.
The combined mass of the girl and her sledge is 40 kg.

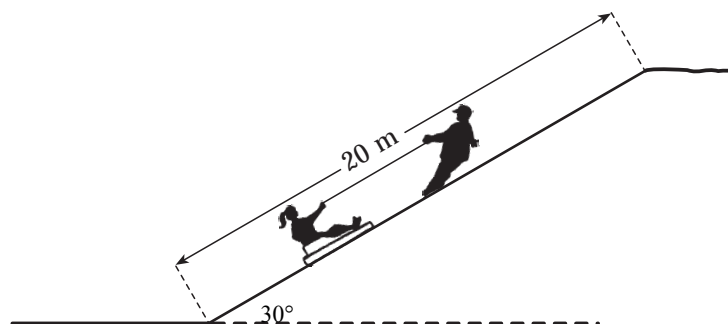

The frictional force exerted by the snow on the sledge is 120 N and can be assumed to be constant in magnitude.

- (a) How much work is done **against friction** by her father when pulling the girl and sledge a distance of 20 m up the slope? 2
- (b) At the top of the slope, the girl and sledge are released from rest, and slide back down the slope.
- (i) What is the unbalanced force acting down the slope on the girl and sledge? 5
- (ii) Calculate the speed of the girl and sledge at the foot of the slope. (7)

23. A student carries out an investigation into the relationship between the volume and temperature of a trapped sample of air. He sets up the apparatus shown below in diagram I.

The student decides to use a temperature sensor connected as part of a Wheatstone bridge circuit, as shown in the diagram II, to measure the temperature of the water. The resistance of the sensor varies uniformly as its temperature changes.

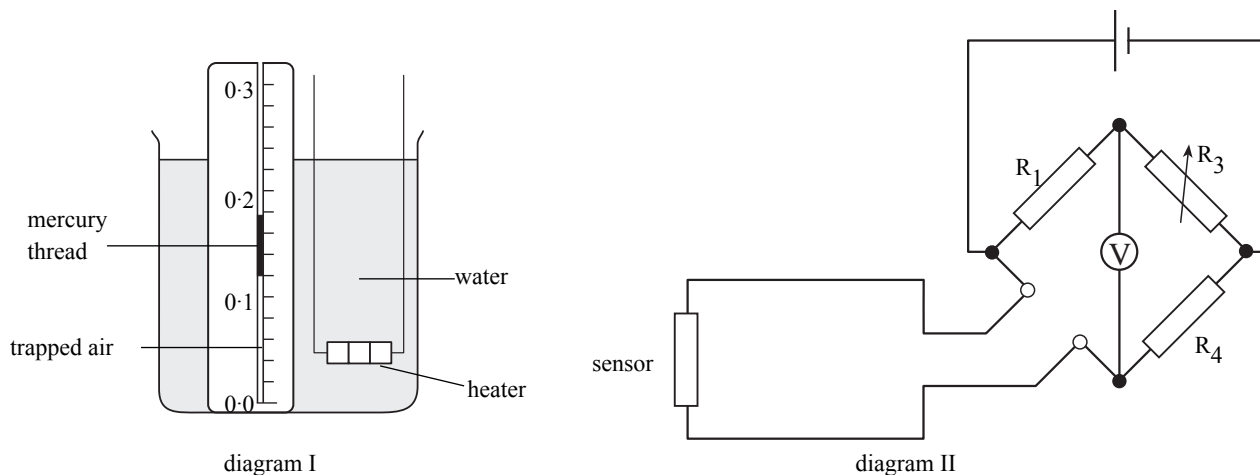

- (a) (i) Explain what is meant by a **balanced** Wheatstone bridge.
- (ii) How should the student calibrate the voltmeter as part of the bridge circuit for use as a thermometer over the range 0 °C to 100 °C. No other thermometer is available for use.
- (b) Using the apparatus shown in diagram I, the student places the temperature sensor in the beaker of water. By heating the water, the student obtains a series of results for the volume and temperature of the trapped air. The results are shown in the table below.

3

Volume/units	42	45	46	49	51
Temperature/°C	15	30	45	60	75
Temperature/K					

- (i) Copy the above table. Complete the table, giving the temperature in kelvin.
- (ii) Use **all** of the data from your completed table to establish the relationship between the volume and temperature of the trapped air.
- (iii) State **two** properties of the trapped air which should be kept constant during this investigation.

4

(7)

24. The diagram illustrates a cathode ray tube used in an oscilloscope.

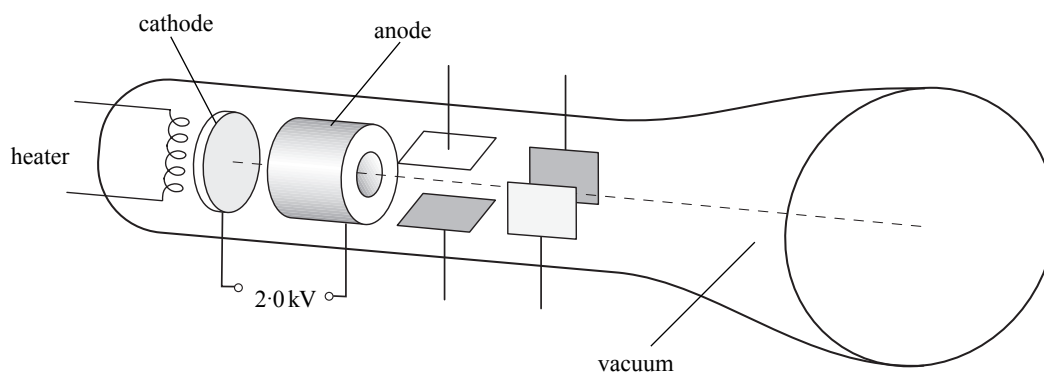

Electrons are released from the hot cathode and are accelerated uniformly by a p.d. of 2.0 kV between the cathode and anode. The distance between the cathode and anode is 0.10 m.

- (a) Show that the amount of work done in accelerating an electron between the cathode and anode is 3.2×10^{-16} J. 1
- (b) Assuming that the electrons start from rest at the cathode, calculate the speed of an electron just as it reaches the anode. 2
- (c) (i) Show that the acceleration of an electron as it moves from the cathode to the anode is $3.5 \times 10^{15} \text{ m s}^{-2}$. 4
- (ii) Calculate the time taken by an electron to travel from the cathode to the anode. 4
- (d) The distance between the cathode and anode in the cathode ray tube is increased. The same p.d. is applied between the cathode and anode. Explain the effect this has on the speed of an electron just as it reaches the anode. 2

(9)

25. The diagram shows a circuit used to control the temperature in a water bath.

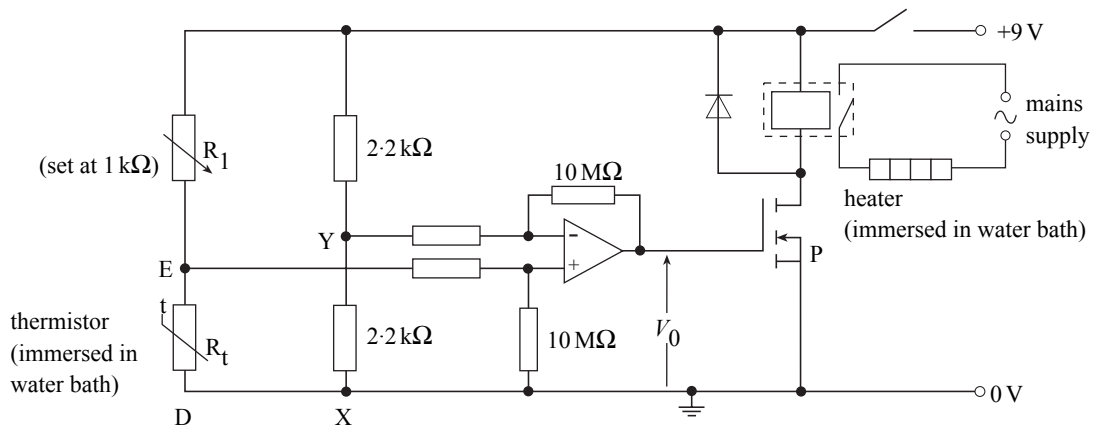

The graph below shows how the resistance of the thermistor varies with its temperature.

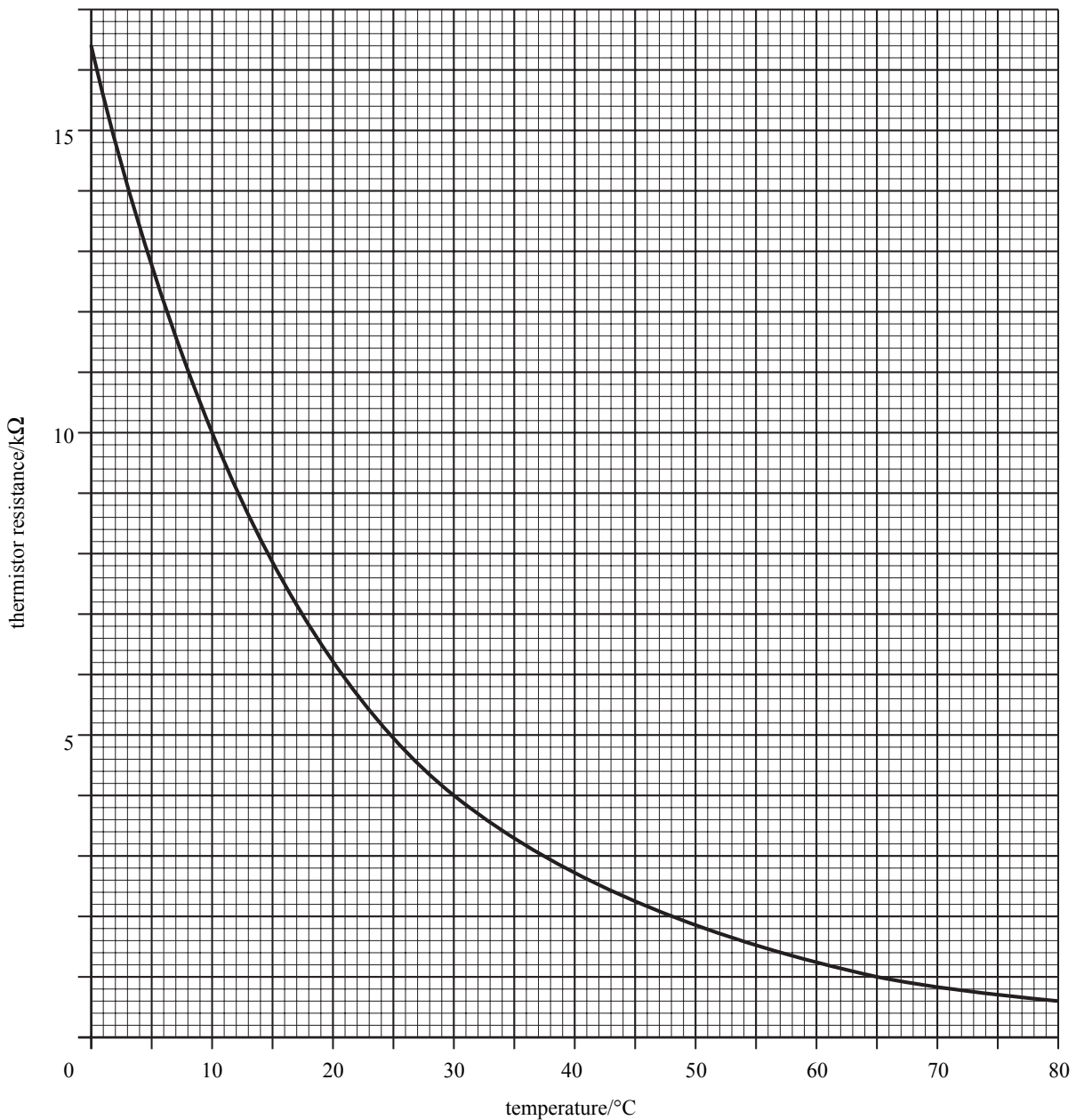

25.(continued)

Switch S is now closed. The temperature of the water in the bath is 8°C .

- | | |
|--|------------|
| (a) Calculate the potential difference across XY. | 1 |
| (b) Calculate the potential difference across DE. | 3 |
| (c) When the switch S is closed and the temperature of the water is 8°C , the heater is switched on by the circuit.
Explain fully how this happens. | 2 |
| (d) In the circuit diagram, what is the component whose symbol is labelled P? | 1 |
| | (7) |

26.A $220\ \mu\text{F}$ capacitor is to be charged using the circuit shown below.

The $12\ \text{V}$ battery has negligible internal resistance.

The capacitor is initially uncharged.

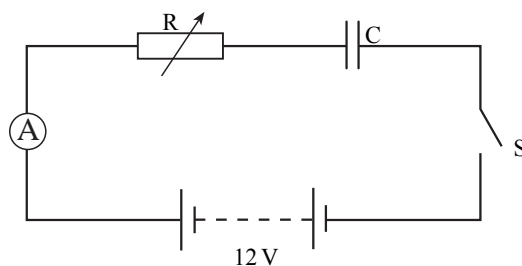

After switch S is closed, the charging current is kept constant at $20\ \mu\text{A}$ by adjusting the resistance of the variable resistor, R , while the capacitor is charging.

- (a) What is the initial resistance of R ? 2
- (b) While the capacitor is charging, should the resistance of R be increased or decreased to keep the current constant?
Justify your answer. 2
- (c) Calculate
- (i) the charge on the capacitor $45\ \text{s}$ after the switch S is closed
 - (ii) the potential difference across R at this time. 5
- (9)**

27.(a) Describe, with the aid of a diagram, how you would use a source of monochromatic light and a semi-circular glass block to measure the critical angle for the light in this glass.

2

(b) A ray of monochromatic light is incident on the face XY of the right angled glass prism as shown below. The diagram is drawn to scale. The refractive index of the glass for this light is 1.49.

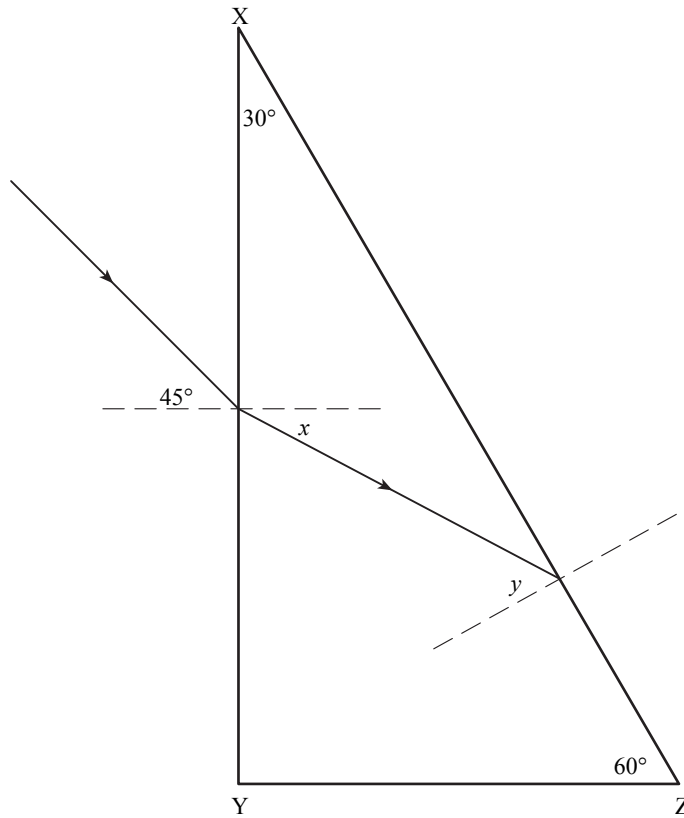

- (i) Use the value given for the refractive index to calculate the size of angle x .
Your working must be shown.
- (ii) Using a protractor, or otherwise, find the size of angle y .
- (iii) Calculate the critical angle for this ray of light in the glass.
- (iv) Describe and explain what happens to the ray of light at face XZ.

7

(9)

- 28.(a) A source of bright red light and a source of faint blue light are shone in turn on to a metal surface for the same length of time.

Light from both sources is found to eject electrons from the metal surface.

- Explain why the maximum kinetic energy of the electrons ejected by the faint blue light is greater than the maximum kinetic energy of the electrons ejected by the bright red light.
- Will the light from the red source eject the same number of electrons every second as the light from the blue source?

Justify your answer.

3

- (b) Radiation of frequency 6.8×10^{14} Hz is shone on to a lithium surface in an evacuated glass tube as shown below. A potential difference V is applied between the collector and the lithium surface by closing switch S.

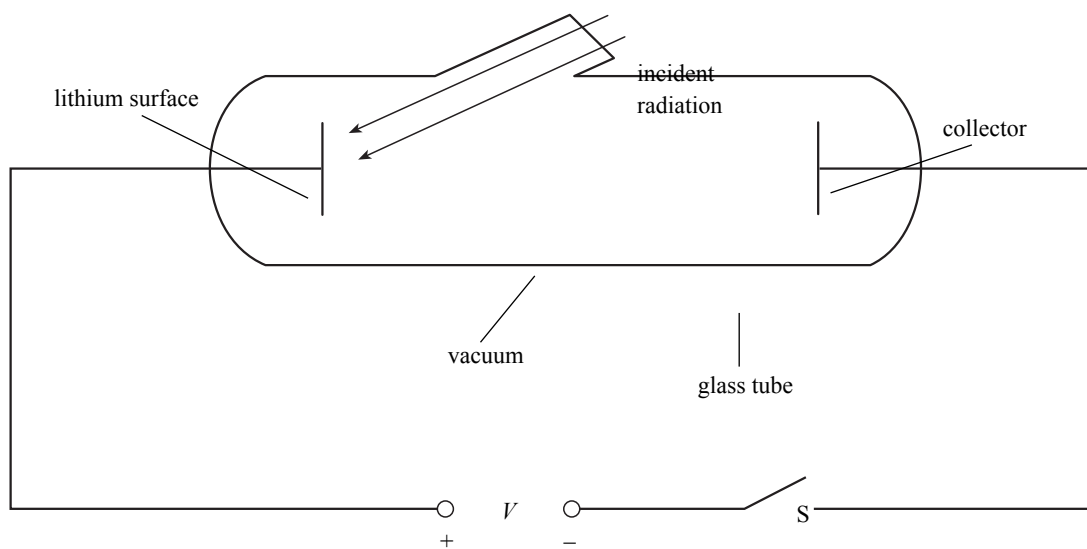

The work function of lithium is 3.7×10^{-19} J.

- Calculate the energy of each photon of the incident radiation.
- Switch S is open.

Determine the maximum kinetic energy of an electron which is ejected from the surface of the lithium by the incident radiation.

- Switch S is now closed.

Calculate the minimum value of the potential difference, V , which would prevent any photoelectrons from reaching the collector.

5

(8)

29.(a) One reaction which takes place in the core of a nuclear reactor is represented as follows.



- (i) State the name given to the above type of reaction.
- (ii) Determine the value of x .
- (iii) Explain briefly why this reaction releases energy.
- (b) In a test laboratory, a sample of tissue is exposed to three different radiations at the same time. Information relating to the radiations and the absorbed dose rates for this tissue is given in the table below.

3

<i>Type of radiation</i>	<i>Quality factor</i>	<i>Absorbed dose rate</i>
Gamma	1	$1000 \mu\text{Gy h}^{-1}$
Thermal neutrons	3	$200 \mu\text{Gy h}^{-1}$
Fast neutrons	10	$40 \mu\text{Gy h}^{-1}$

- (i) Explain the meaning of “absorbed dose”.
- (ii) The sample of tissue is to receive a total dose equivalent of 50 mSv from these radiations. Use the information given to calculate the number of hours of exposure needed for the sample of tissue to receive this required dose equivalent.

4

(7)

[END OF QUESTION PAPER]

PHYSICS

HIGHER

Section A

Specimen Question Paper

NATIONAL QUALIFICATIONS

ANSWER SHEET

Full name of school or college

Town

First name and initials

Surname

Date of birth

Day Month Year

--	--	--	--	--	--

Candidate number

--	--	--	--	--	--	--	--	--	--	--	--

Number of seat

Using ink, indicate your choice of answer by a single stroke joining the two dots in the box, as in the following example:

A	B	C	D	E
· ·	 ·	· ·	· ·	· ·

	A	B	C	D	E
1	· ·	· ·	· ·	· ·	· ·
2	· ·	· ·	· ·	· ·	· ·
3	· ·	· ·	· ·	· ·	· ·
4	· ·	· ·	· ·	· ·	· ·
5	· ·	· ·	· ·	· ·	· ·
6	· ·	· ·	· ·	· ·	· ·
7	· ·	· ·	· ·	· ·	· ·
8	· ·	· ·	· ·	· ·	· ·
9	· ·	· ·	· ·	· ·	· ·
10	· ·	· ·	· ·	· ·	· ·

	A	B	C	D	E
11	· ·	· ·	· ·	· ·	· ·
12	· ·	· ·	· ·	· ·	· ·
13	· ·	· ·	· ·	· ·	· ·
14	· ·	· ·	· ·	· ·	· ·
15	· ·	· ·	· ·	· ·	· ·
16	· ·	· ·	· ·	· ·	· ·
17	· ·	· ·	· ·	· ·	· ·
18	· ·	· ·	· ·	· ·	· ·
19	· ·	· ·	· ·	· ·	· ·
20	· ·	· ·	· ·	· ·	· ·