



2006 Graphic Communication

Intermediate 2

Finalised Marking Instructions

© The Scottish Qualifications Authority 2006

The information in this publication may be reproduced to support SQA qualifications only on a non-commercial basis. If it is to be used for any other purposes written permission must be obtained from the Assessment Materials Team, Dalkeith.

Where the publication includes materials from sources other than SQA (secondary copyright), this material should only be reproduced for the purposes of examination or assessment. If it needs to be reproduced for any other purpose it is the centre's responsibility to obtain the necessary copyright clearance. SQA's Assessment Materials Team at Dalkeith may be able to direct you to the secondary sources.

These Marking Instructions have been prepared by Examination Teams for use by SQA Appointed Markers when marking External Course Assessments. This publication must not be reproduced for commercial or trade purposes.

Question 1

a. Hatch

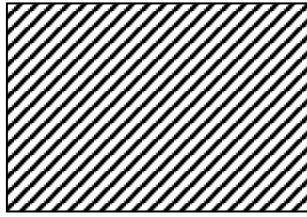

b. Solid

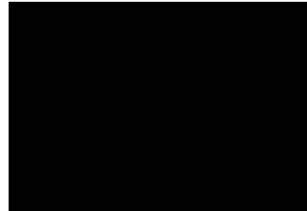

c. Gradient



1 mark each

3 Marks

Question 2

a. Scale, Wiring, Plumbing, Doors, Windows, Room Layout, Furniture, etc.

Any 2 – 1 mark each

b. Plot outline, Building position, Drainage, Trees and Shrubs, North Symbol

Any 2 – 1 mark each

c. Streets etc., Surrounding building plots, Street names, North, Boundaries

Any 2 – 1 mark each

**NB 6 different answers must be given for full marks.
The same answer cannot be used for a, b and c.**

6 Marks

Question 3

- a. Scanner 1 mark
- b. Digital Camera 1 mark

2 Marks

Question 4

- a. Mirror 1 mark
- b. Library 1 mark
- c. Layers 1 mark

3 Marks

Question 5

- a. Radius W shown correctly 1 mark
(2 out of the three components – ½ mark)
- b. Angle X shown correctly 1 mark
(2 out of the three components – ½ mark)
- c. Height Y shown correctly 1 mark
(2 out of the three components – ½ mark)
- d. Length Z shown correctly 1 mark
(2 out of the three components – ½ mark)

Total marks

4 marks

NB Dimensioning components are: **leader lines**, **dimension line with arrows** and **position of text**.

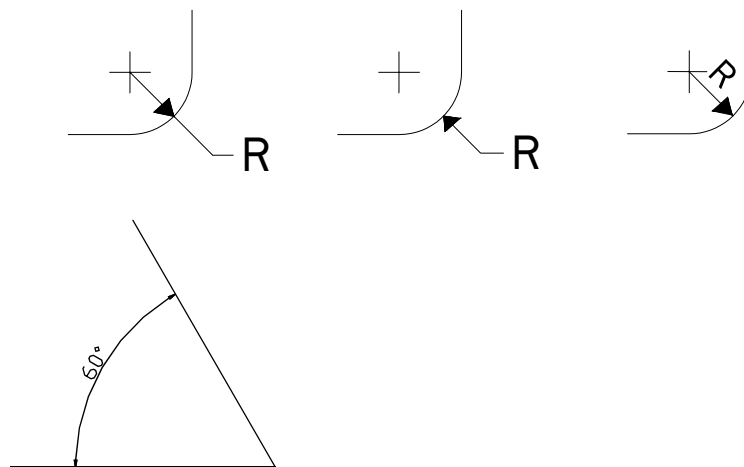

Question 6

- a. i. Header 1 mark
- ii. Footer 1 mark

- b. 1 mark

3 Marks

Notes for drawing questions:

- Tolerances for all drawings $\pm 1\text{mm}$
- When marking drawings, all markers must operate the “follow-on rule” and ensure that candidates are **not** penalised twice.
- Marks should be entered in the appropriate place and no other comments added to the candidates scripts.

Half marks should not be rounded up for each question, but when adding up the marks on the front cover, if the total mark has a half mark, this should be rounded up

Question 7

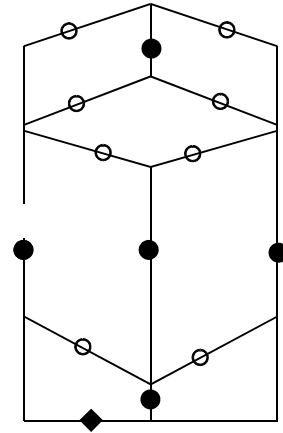
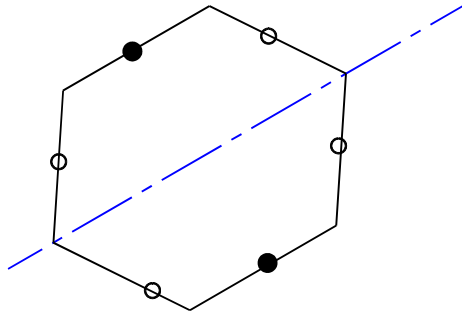

End Elevation



- a. 5 Vertical lines marked ● **1 mark**
- 4-5 1 mark
- 2-3 ½ mark
- b. 1 Horizontal line marked ◆ ½ mark
- c. 8 Sloping lines marked ○ **2 marks**
- 7-8 2 marks
- 5-6 1½ marks
- 3-4 1 mark
- 1-2 ½ mark

True Shape

- d. 2 lines marked ● **1 mark**
- 2 1 mark
- 1 ½ mark
- e. 4 lines marked ○ **1 mark**
- 3-4 1 mark
- 1-2 ½ mark

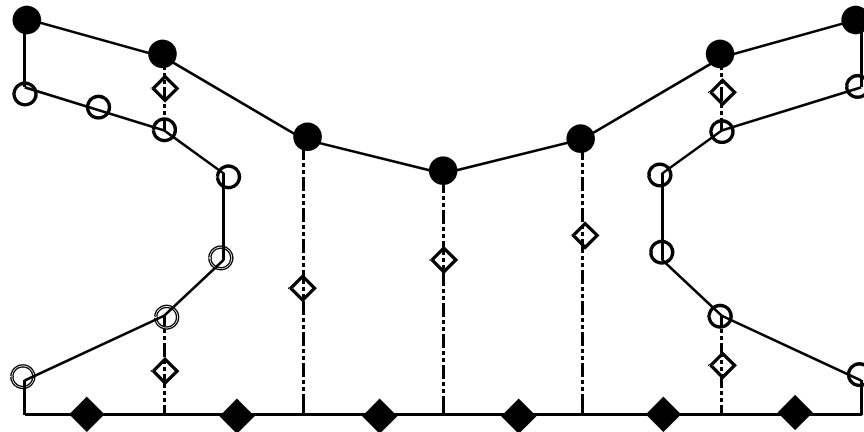
Development



- f. 6 correctly spaced sides marked  **1 mark**
- g. Development opened correctly along seam A:A **½ mark**
- h. 7 Heights marked  **1½ marks**
- | | |
|-----|----------|
| 6-7 | 1½ marks |
| 4-5 | 1 mark |
| 2-3 | ½ mark |
- i. 12 Heights marked  **2½ marks**
- | | |
|-------|----------|
| 10-12 | 2½ marks |
| 7-9 | 2 marks |
| 5-6 | 1½ marks |
| 3-4 | 1 mark |
| 1-2 | ½ mark |
- j. 5 fold lines shown correctly **1 mark**

Total 12 marks

Question 8

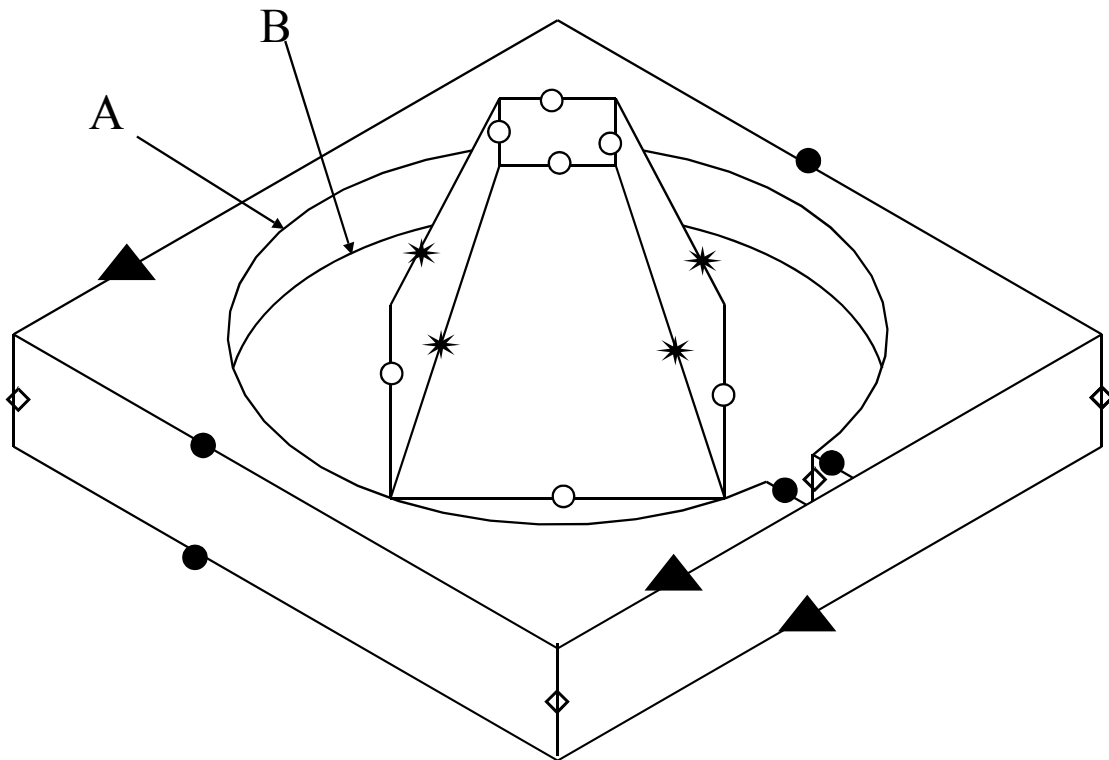

- | | | | |
|----|-------------------------|----------|----------------|
| a. | 4 Vertical lines marked | ◇ | 1 mark |
| | 1-3 | ½ mark | |
| b. | 5 LH lines marked | ● | 1 mark |
| | 4-5 | 1 mark | |
| | 1-3 | ½ mark | |
| c. | 3 RH lines marked | ▲ | 1 mark |
| | 3 | 1 mark | |
| | 1-2 | ½ mark | |
| d. | Construction on plan | | ½ mark |
| e. | Curve A – 12 points | | 2 marks |
| | 10-12 | 2 marks | |
| | 7-9 | 1½ marks | |
| | 4-6 | 1 mark | |
| f. | Quality of curve | | 1 mark |
| | Good | 1 mark | |
| | Poor | ½ mark | |

Question 8 cont'd

- g. Curve B – 6 points **1½ marks**
- | | |
|------------|----------|
| 5-6 points | 1½ marks |
| 3-4 points | 1 mark |
- h. Quality of curve **1 mark**
- | | |
|------|--------|
| Good | 1 mark |
| Poor | ½ mark |
- i. 7 lines marked ○ **3 marks**
- | | |
|------------|---------|
| 6-7 points | 3 marks |
| 4-5 points | 2 marks |
| 2-3 points | 1 mark |
- j. 4 sloping lines marked * **2 marks**
- | | |
|-----------|---------|
| 3-4 lines | 2 marks |
| 1-2 lines | 1 mark |

Total 14 marks

Question 9 – Section End Elevation

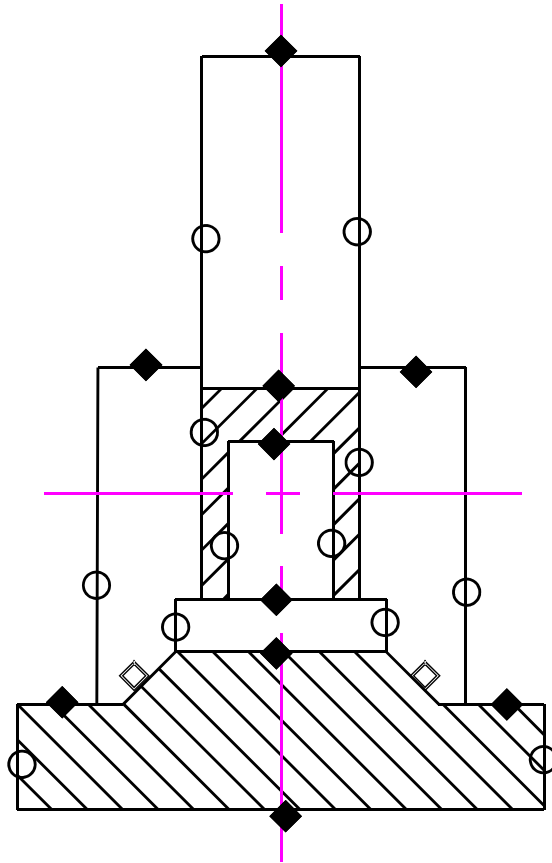

- i. 12 vertical lines marked 2 marks
- | | |
|-------|----------|
| 11-12 | 2 marks |
| 8-10 | 1½ marks |
| 5-7 | 1 mark |
| 2-4 | ½ mark |
- j. 10 horizontal lines marked 1½ marks
- | | |
|------|----------|
| 8-10 | 1½ marks |
| 5-7 | 1 mark |
| 2-4 | ½ mark |
- k. 2 sloping lines marked ½ mark
- l. 3 parts treated correctly for hatching 1½ marks
(2 parts hatched correctly – 1 mark)
- m. 45° angle used ½ mark
- n. Differentiation between sectioned surfaces ½ mark

Total 13 marks

Question 10

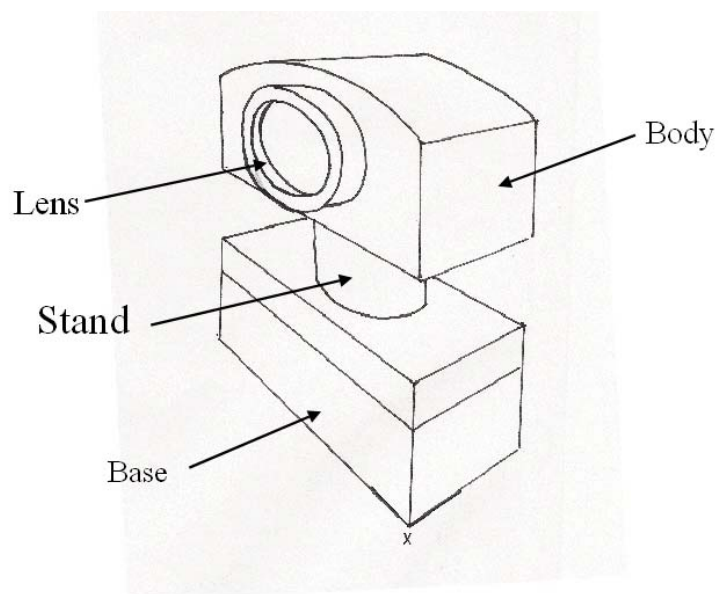

Base

- a. Base drawn in good proportion/perspective **1 mark**
- b. Base detail **½ mark**

Stand

- c. Stand drawn in good proportion/perspective **1 mark**
- d. Stand centred to Base/Body **½ mark**
- e. Curve on face **½ mark**

Body

- f. Body drawn in good proportion/perspective **1 mark**
- g. Curve on Face **1 mark**
- h. Curve on Back **1 mark**

Lens

- i. Lens drawn in good proportion/perspective **1 mark**
- j. Lens centred to body **½ mark**
- k. 4 Circles/Curves @ ½ each **2 marks**

Total 10 marks

[END OF MARKING INSTRUCTIONS]