

**2006 Graphic Communication**

**Standard Grade – General**

**Finalised Marking Instructions**

© The Scottish Qualifications Authority 2006

The information in this publication may be reproduced to support SQA qualifications only on a non-commercial basis. If it is to be used for any other purposes written permission must be obtained from the Assessment Materials Team, Dalkeith.

Where the publication includes materials from sources other than SQA (secondary copyright), this material should only be reproduced for the purposes of examination or assessment. If it needs to be reproduced for any other purpose it is the centre's responsibility to obtain the necessary copyright clearance. SQA's Assessment Materials Team at Dalkeith may be able to direct you to the secondary sources.

These Marking Instructions have been prepared by Examination Teams for use by SQA Appointed Markers when marking External Course Assessments. This publication must not be reproduced for commercial or trade purposes.

**General**

- 1 (a) 2 & 4 KI 2  
 (b) Isometric KI 1

**TOTAL KI 3**

- 2 (a) P...1pt Perspective Q...Planometric  
 R...Oblique S...2pt Perspective KI 4  
 (b) Angle X...45 Degrees KI 1  
 Angle Y...30 Degrees KI 1  
 Angle Z...60 Degrees

**TOTAL KI 6**

- 3 (a) Arc  
 (b) Hatch/ Pattern Fill  
 (c) Text  
 (d) Line/ Polyline  
 (e) Rectangle  
 (f) Fillet  
 (g) Circle  
 (h) Chamfer/ Trim bevel  
 (i) Zoom/ Magnify/ Detail/ Scale  
 (j) Dimension  
 (k) Copy/ Linear array/ Box array/ Array/ Duplicate  
 (l) Mirror/ Flip

**TOTAL KI 11**

- 4 (a) A...Site B...Location/ Block C...Floor KI 3  
 (b) D...Site E...Sawn Timber  
 F...North G...Brickwork  
 H...Socket outlet I...Lamp/ Light fitting  
 J...Switch KI 7

**TOTAL KI 10**

5

<i>Safe condition</i>		<i>Green</i>	<i>None</i>		KI 1
-----------------------	---	--------------	-------------	--	------

<i>Prohibition</i>		<i>White</i>	<i>Red</i>		KI 2
--------------------	---	--------------	------------	--	------

<i>Warning</i>		<i>Yellow</i>	<i>Black</i>		KI 2
----------------	---	---------------	--------------	--	------

**TOTAL KI 5**

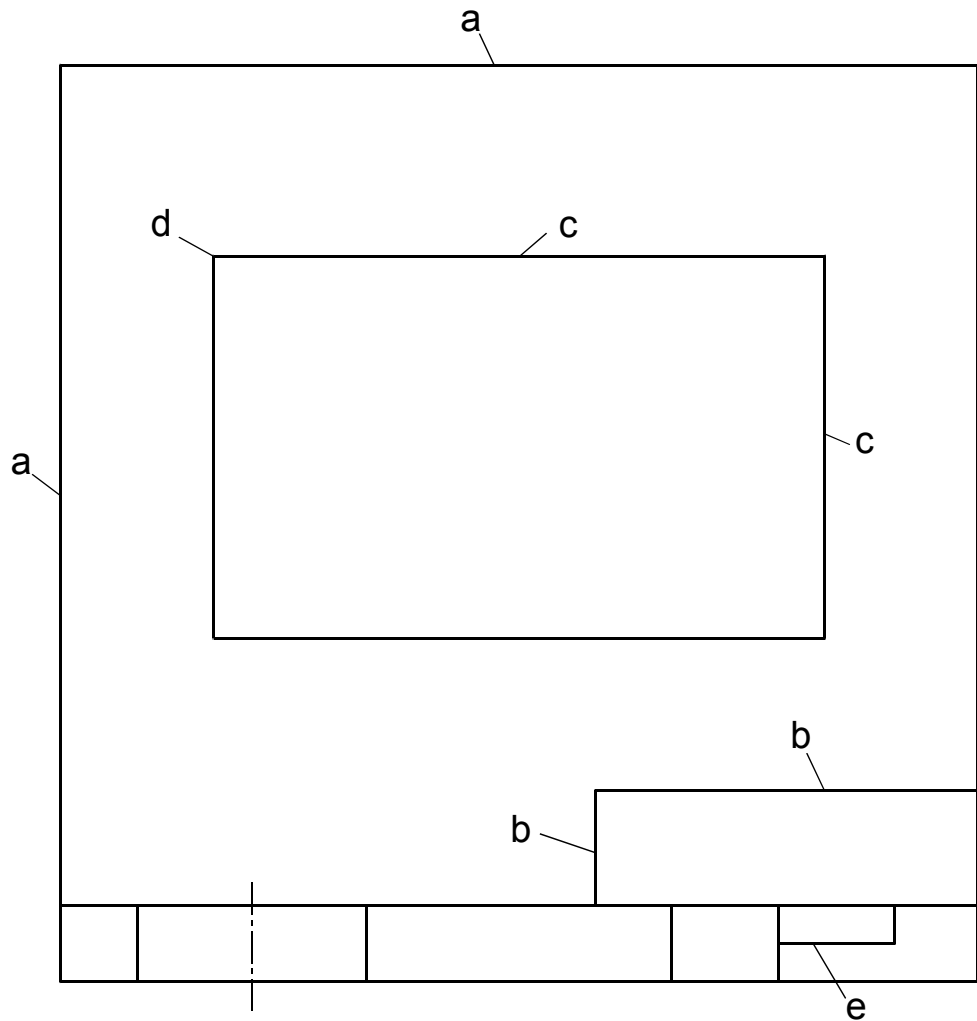

- (a) Width + Length 1
- (b) Lines width correct 1
- (c) Rect. Size 1
- (d) Rect. Position 1
- (e) Button size 1
- (f) Width = Line 1

DA 6

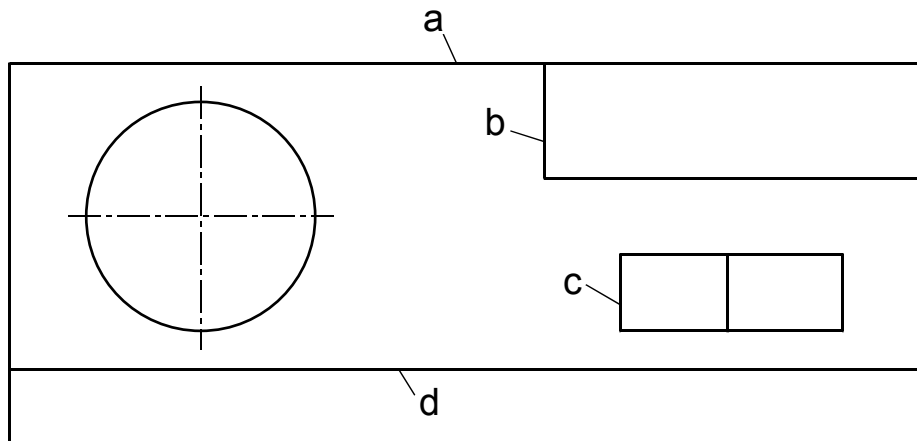

General 2006 qu. 6.

- (a) Length 120 1
- (b) Length 50 + vert line 1
- (c) Button size + pos. 1
- (d) Line 1

DA 4

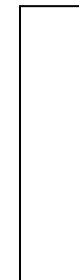

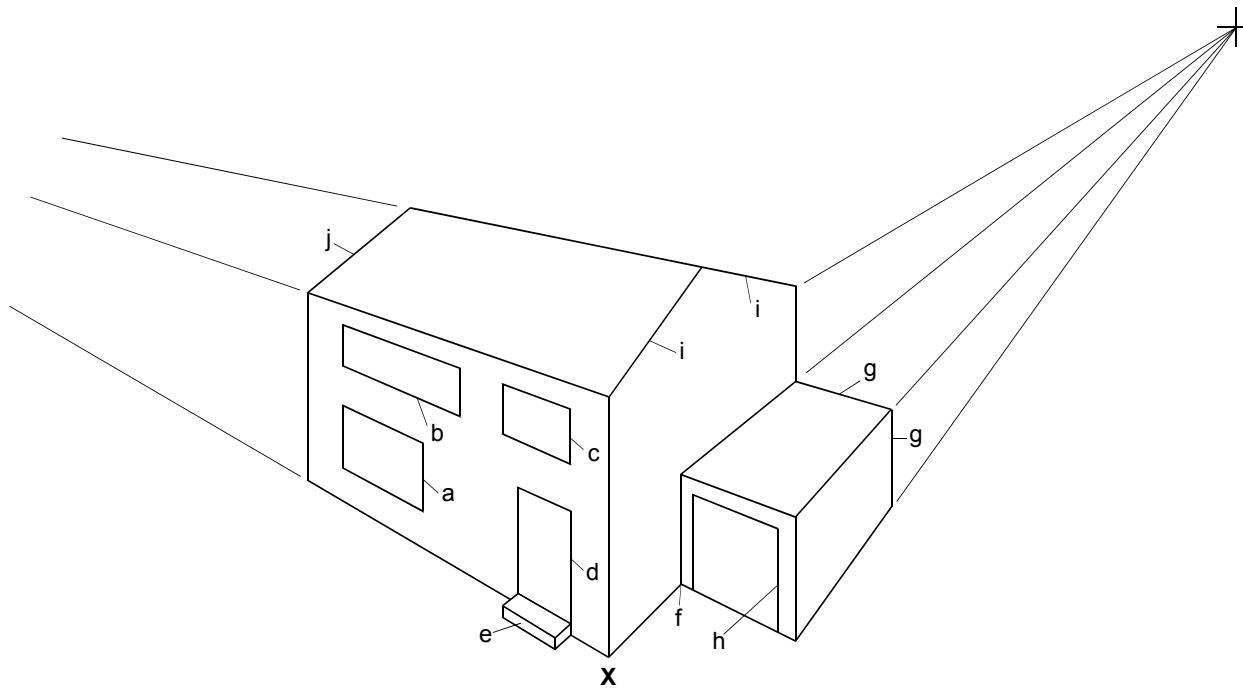

**General 2006 qu.7.**

**Sketch in good perspective 2**

**House in good proportion 2**

- |                                 |          |
|---------------------------------|----------|
| <b>(a) Window</b>               | <b>1</b> |
| <b>(b) Window</b>               | <b>1</b> |
| <b>(c) Window</b>               | <b>1</b> |
| <b>(d) Door</b>                 | <b>1</b> |
| <b>(e) Step width + height</b>  | <b>1</b> |
| <b>(f) Garage position</b>      | <b>1</b> |
| <b>(g) Garage in good prop.</b> | <b>1</b> |
| <b>(h) Door</b>                 | <b>1</b> |
| <b>(i) Roof lines</b>           | <b>1</b> |
| <b>(j) Roof line</b>            | <b>1</b> |

**Total DA 14**

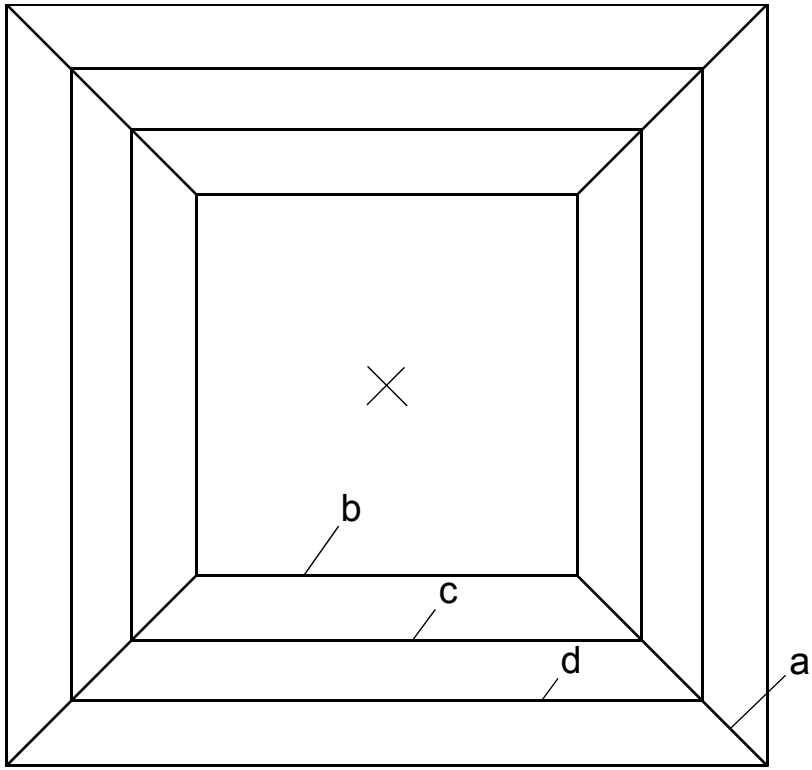

**General 2006 qu. 8.**

- (a) Sloping lines**                    1
- (b) Correct size**                    1
- (c) Correct size**                    1
- (d) Correct size**                    1

**DA 4**

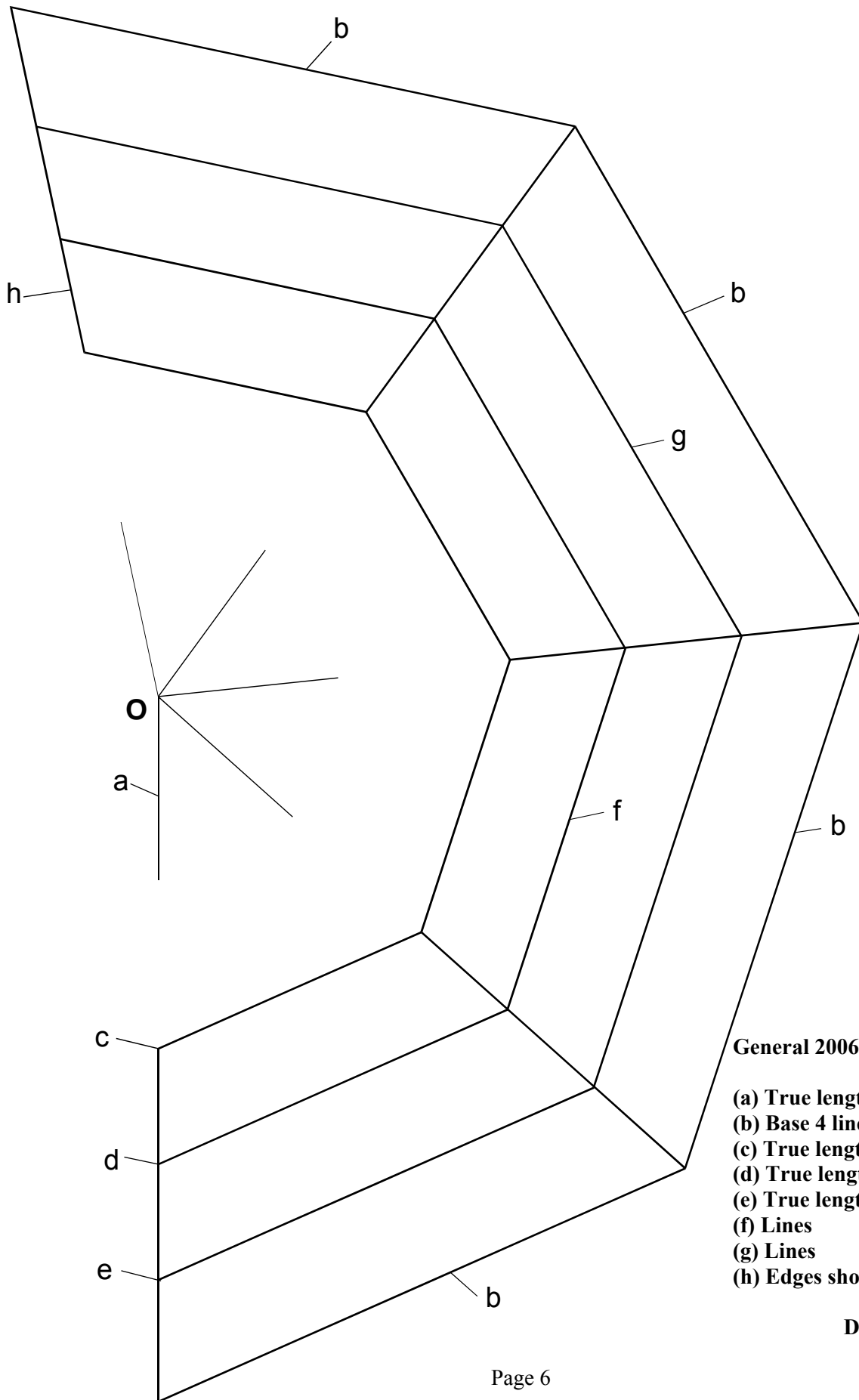

General 2006 qu. 8.

- |                         |   |
|-------------------------|---|
| (a) True length correct | 1 |
| (b) Base 4 lines shown  | 1 |
| (c) True length         | 1 |
| (d) True length         | 1 |
| (e) True length         | 1 |
| (f) Lines               | 1 |
| (g) Lines               | 1 |
| (h) Edges shown         | 1 |

DA 8

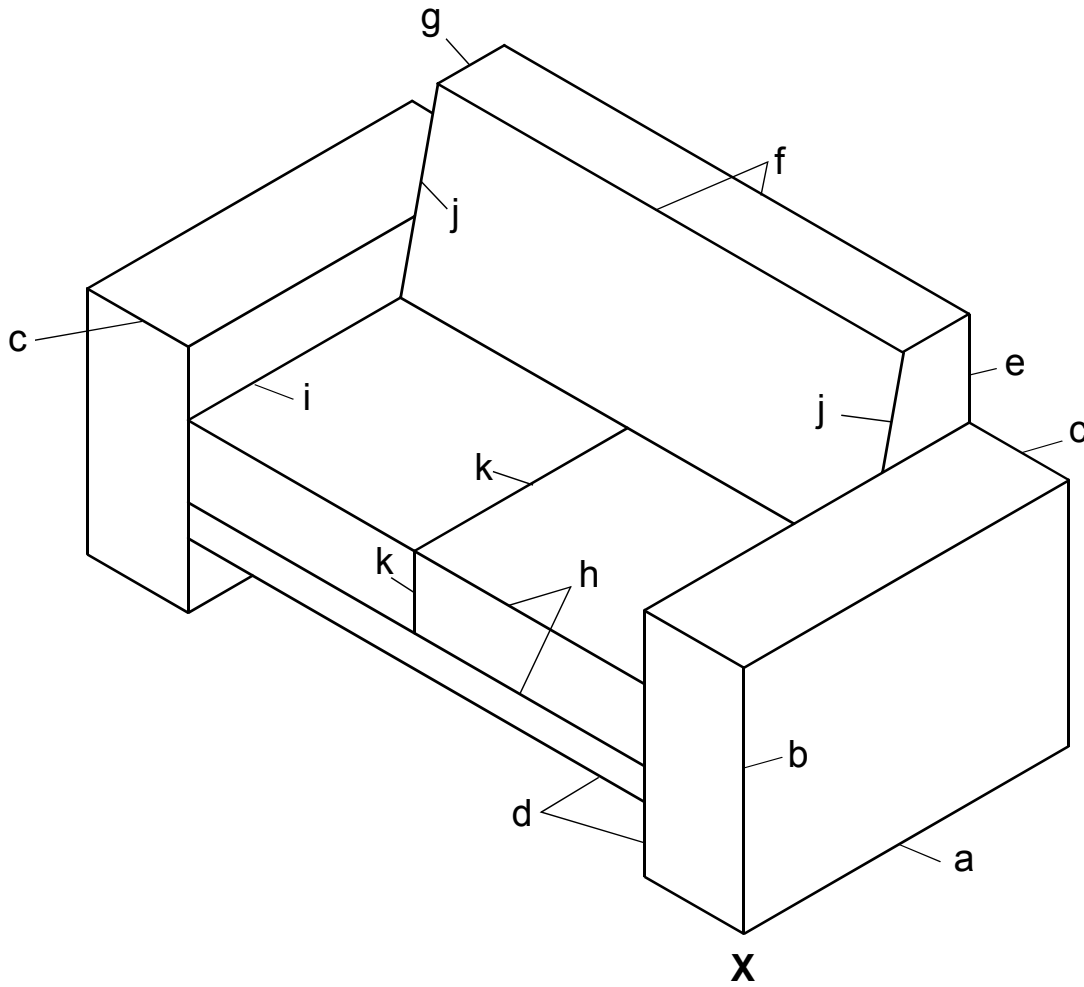

**General 2006 qu.9.**

<b>(a) Width</b>	<b>1</b>
<b>(b) Height</b>	<b>1</b>
<b>(c) Length</b>	<b>1</b>
<b>(d) Height + line</b>	<b>1</b>
<b>(e) Height</b>	<b>1</b>
<b>(f) Length + 2 lines</b>	<b>1</b>
<b>(g) Width</b>	<b>1</b>
<b>(h) 2 lines</b>	<b>1</b>
<b>(i) Width</b>	<b>1</b>
<b>(j) Sloping lines</b>	<b>1</b>
<b>(k) Cushion lines (both)</b>	<b>1</b>

**Total DA 14**

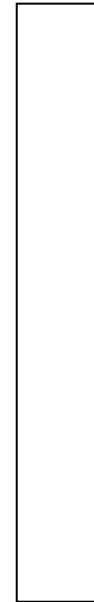

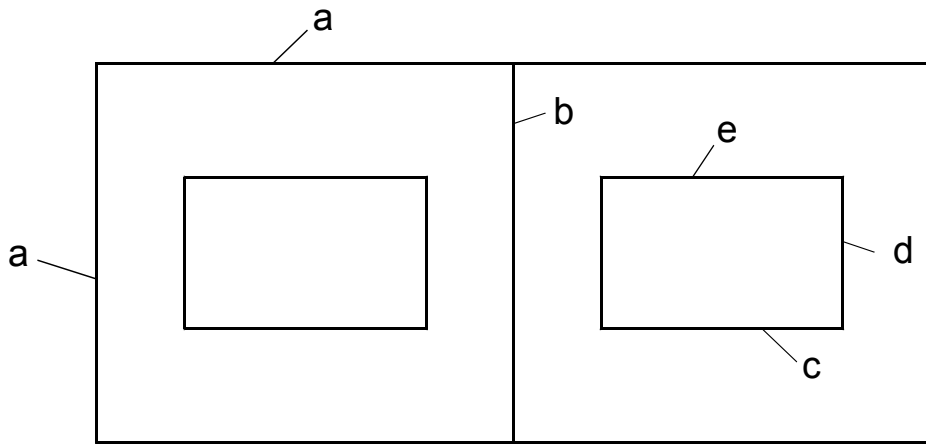

**Plan**

- (a) Width 1
- (b) Line 1
- (c) Position 1
- (d) Width 1
- (e) Size 1
- (f) Both inserts 1

DA 6

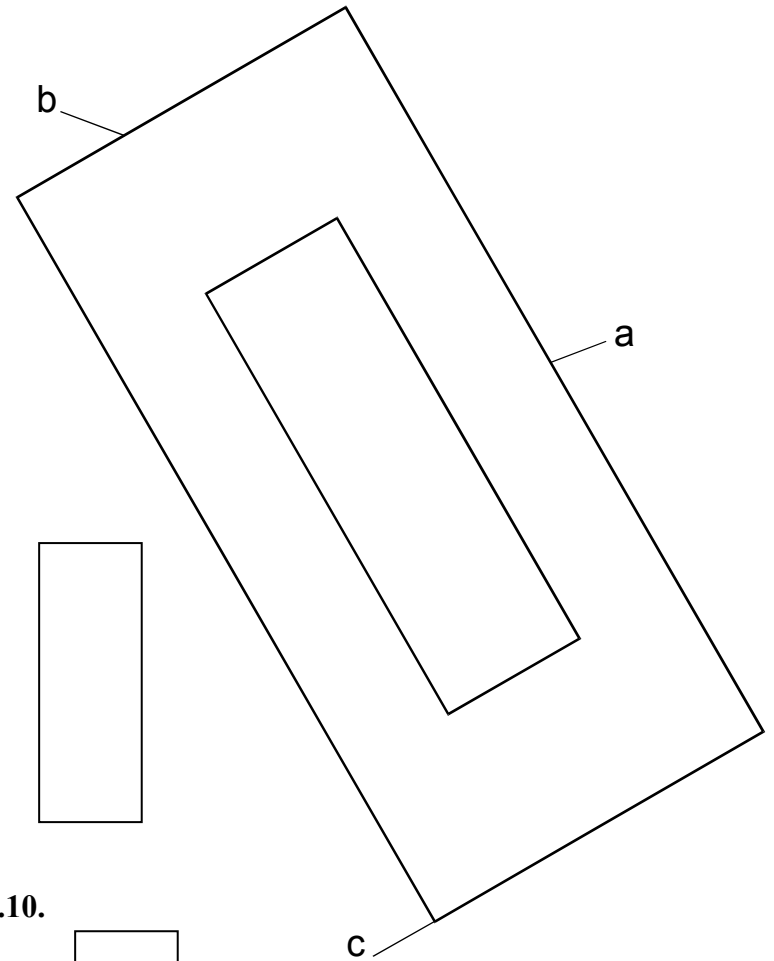
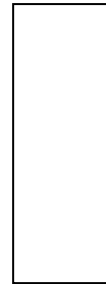

**True Shape**

- (a) Length 1
  - (b) Width 1
  - (c) Projection 1
- DA 3

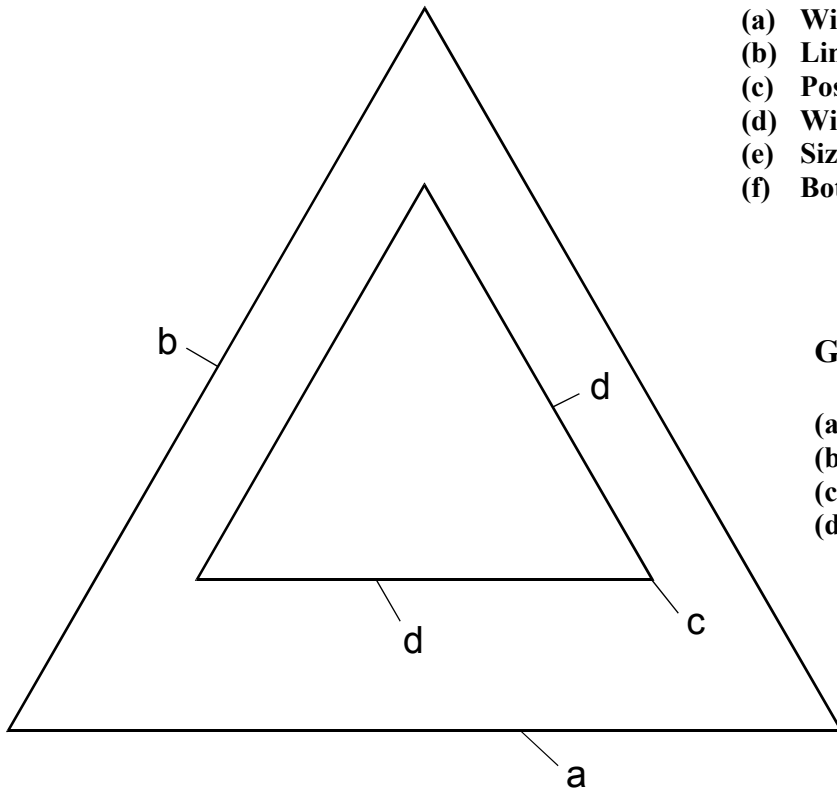

**General 2006 qu.10.**

- (a) Length 110 1
- (b) Triangle size 1
- (c) Position 1
- (d) Triangle size 1

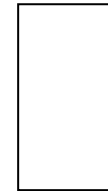

[END OF MARKING INSTRUCTIONS]