

C033/SQP315

Graphic Communication
Intermediate 1

NATIONAL
QUALIFICATIONS

<i>Contents</i>	<i>Page</i>
Course Assessment Specification	2
Specimen Question Paper	5
Specimen Marking Instructions	15

Course Assessment Specification

Intermediate 1 Graphic Communication

The purpose of this document is to provide:

- ◆ Details of the structure of the Course Assessment for this Course
- ◆ Guidance to Centres on how to use information gathered from the Question Paper and the Graphic Presentation Folio to estimate candidate performance.

Part 1

This part of the Course Assessment Specification details the structure of the Course Assessment for this Course.

The Course Assessment consists of two components as follows:

Component	Time Allocation	Mark Allocation
Question Paper	2 hours	70
Graphic Presentation Folio	Completed During Course	30

The Question Paper

- ◆ The Question Paper has a mark allocation of 70 marks.
- ◆ The Question Paper has a time allocation of 2 hours.
- ◆ The Question Paper contains short response questions on British Standards, computer terminology, colour theory and the advantages of computer graphics.
- ◆ The Question Paper contains questions on manual drawing which test application of pictorial and orthographic projections.
- ◆ The ratio of marks allocated to Knowledge and Drawing questions is approximately 15:55.

More information on the Question Paper can be found in the Course Arrangements document.

The Graphic Presentation Folio

- ◆ The Graphic Presentation Folio has a mark allocation of 30 marks.
- ◆ Items for the folio are produced throughout the duration of the Course.
- ◆ Candidates can select their best Unit work suitably enhanced. Or create additional items for inclusion in the Graphic Presentation Folio.
- ◆ The folio must contain:
 - one presentation example of manual rendering (mono or colour)
 - one CAD orthographic drawing of an everyday object
 - one CAD pictorial drawing of an everyday object
 - one single page illustration and presentation graphic produced using an illustration and presentation package
 - one single page DTP layout containing text and graphics.
- ◆ The folio is marked internally, using the Guidance to Assessment document which is produced by the SQA, and subject to external verification.

More information on the Graphic Presentation Folio can be found in the Course Arrangements document and the Guidance to Assessment document.

Part 2

This part of the Course Assessment Specification provides guidance on how to use assessment information gathered from a preliminary Question Paper and the Graphic Presentation Folio to estimate candidate performance.

Component	Mark Range
Question Paper	0-70
Graphic Presentation Folio	0-30
Total Marks	100

The mark range for each component takes account of the weighting of each component.

In National Qualifications cut-off scores should be set at approximately 70% for Grade A and 50% for Grade C with Grade B falling midway.

For a total mark range of 0-100, the following gives an indication of the cut-off scores based on the candidate's **total** score.

Grade	Band	Mark Range
A	1	85-100
A	2	70-84
B	3	65-69
B	4	60-64
C	5	55-59
C	6	50-54
D	7	45-49
NA	8	40-44
NA	9	0-39

These cut-off scores may be lowered if the Question Paper component turns out to be more demanding or raised if less demanding.

Worked example

- ◆ In a centre's own prelim, a candidate scores 40/70, and the candidate scores 21/30 in the Graphic Presentation Folio
- ◆ The two marks are added together, giving a total of 61/100
- ◆ The centre's view is that the prelim is slightly less demanding than the SQA examination
- ◆ Using the mark range, a realistic estimate may be **band 5** rather than band 4.

STAPLE HERE

FOR OFFICIAL USE

--	--	--	--	--	--

C033/SQP315

Graphic
Communication
Intermediate 1
Specimen Question Paper

Time: 2 hours

NATIONAL
QUALIFICATIONS

Fill in these boxes and read what is printed below.

Full name of centre

Town

Forename(s)

Surname

Date of birth

Day Month Year

--	--	--	--	--	--	--	--

Scottish candidate number

--	--	--	--	--	--	--	--	--	--

Number of seat

70 marks are allocated to this paper

- 1 Answer **all** questions.
- 2 Read each question carefully before you answer.
- 3 Written answers may be in **ink** or **pencil**.
- 4 Drawings and sketches **must be in pencil**.
- 5 Dimensions are given in millimetres or as stated.
- 6 Orthographic drawings are in third angle projection.

At the end of the examination

check that your name is on every sheet;
put the sheets in correct numerical order;
place this sheet on top of the others;
join all sheets together by **stapling** at the top left-hand corner;
before leaving the examination room, you must give these sheets to the invigilator
(if you do not you may lose all the marks for this paper).

Question	Marks
1	
2	
3	
4	
5	
6	
7	
8	
9	
Total Marks	

[BLANK PAGE]

1

Colour can be used for many different reasons.

(a) State **one** colour which contrasts with the colour red.

Contrasting colour _____ (1)

(b) Colours can be grouped as warm, cool and neutral. State **one** warm and **one** cool colour.

Warm colour _____ Cool colour _____ (2)

(c) State the effect of using an **advancing** colour in a graphic presentation.

Effect _____ (1)

Total (4)

2

A variety of drawing types are used in industry.

(a) State the type of isometric view shown below. _____ (1)

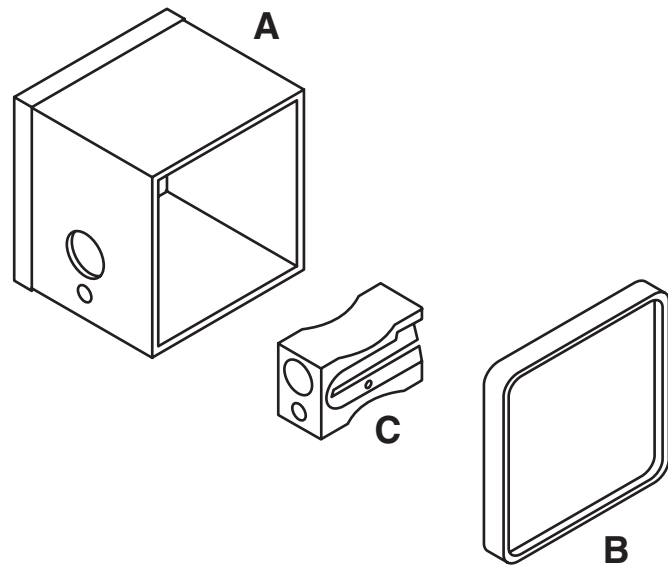

Total (2)

2

(b) State the type of orthographic view shown below. _____ (1)

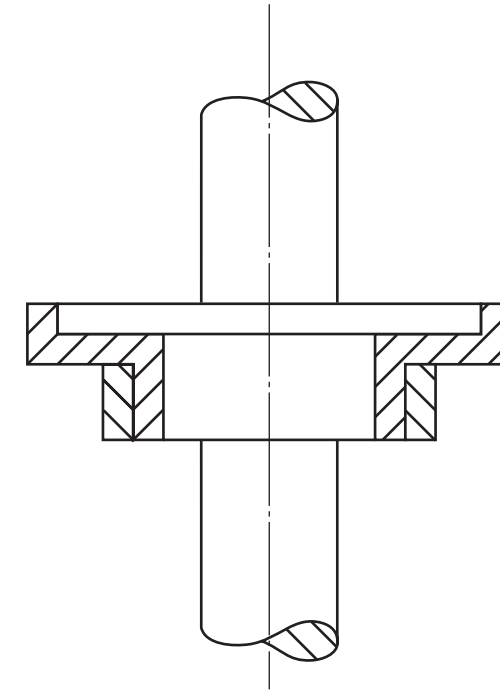

3

Identify the following line types.

- A _____
- B _____
- C _____
- D _____

Answers

- A _____ B _____
- C _____ D _____

Total (4)

4

Identify the computer hardware shown below.

A



B

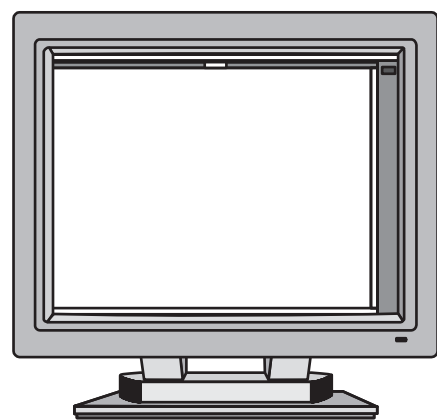

C

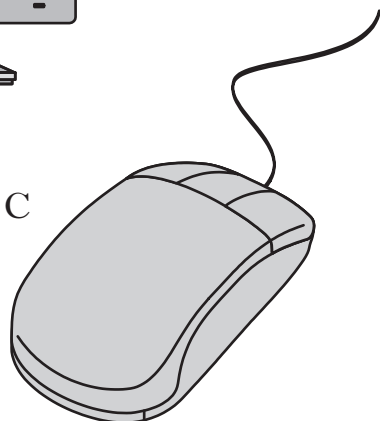

D

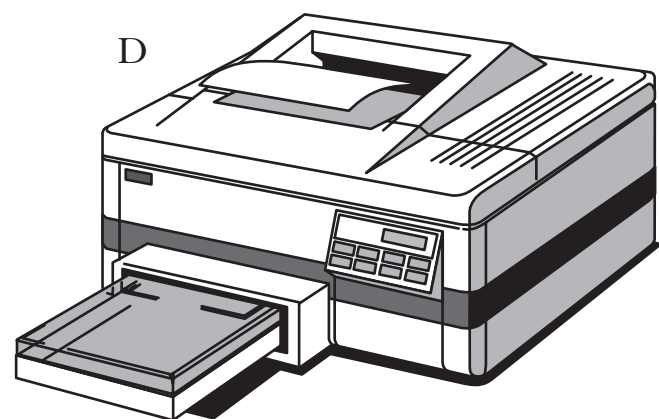

E

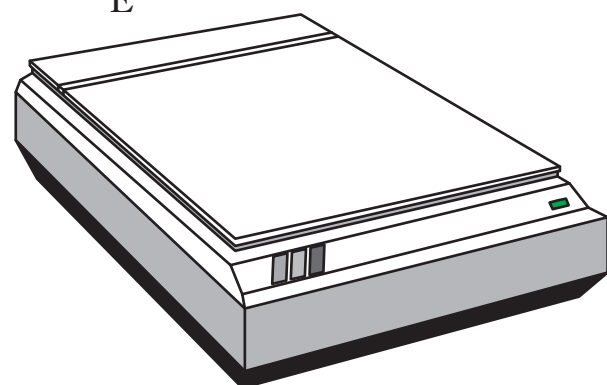

A _____

B _____

C _____

D _____

E _____

Total (5)

5

The plan, elevation and end elevation of a digital meter are given.

Draw in the position given, the **isometric** view of the meter using starting point **X**.

Do not show hidden detail.

(12 marks)

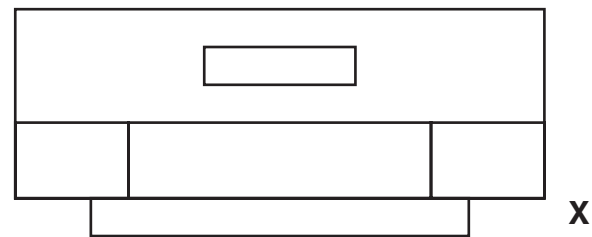

Plan

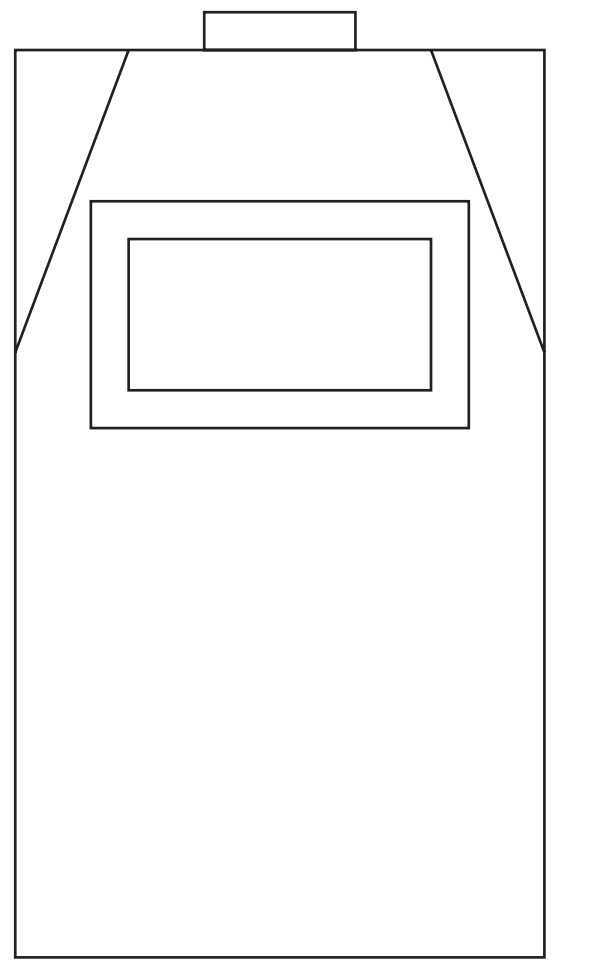

Elevation

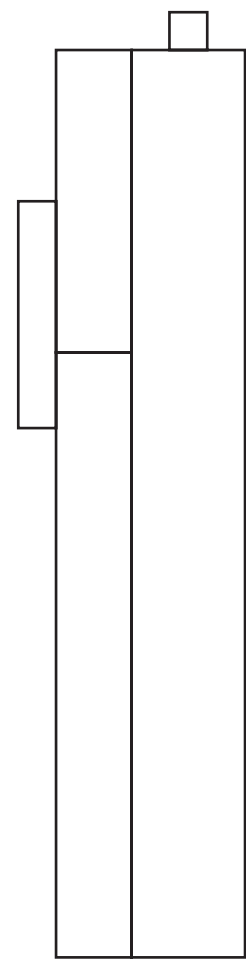

End Elevation

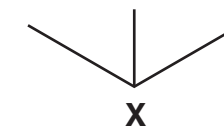

Isometric View

<i>a</i>	
<i>b</i>	
<i>c</i>	
<i>d</i>	
<i>e</i>	
<i>f</i>	
<i>g</i>	
<i>h</i>	
<i>i</i>	
<i>j</i>	
<i>k</i>	
<i>l</i>	
<i>m</i>	
<i>n</i>	

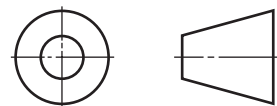

6

An isometric view of a digital TV box is given.

Draw, full size:

(a) the elevation;

(b) the plan;

(c) the end elevation.

(10 marks)

Show all hidden detail.

Plan

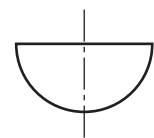

Elevation

End Elevation

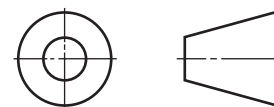

Elevation

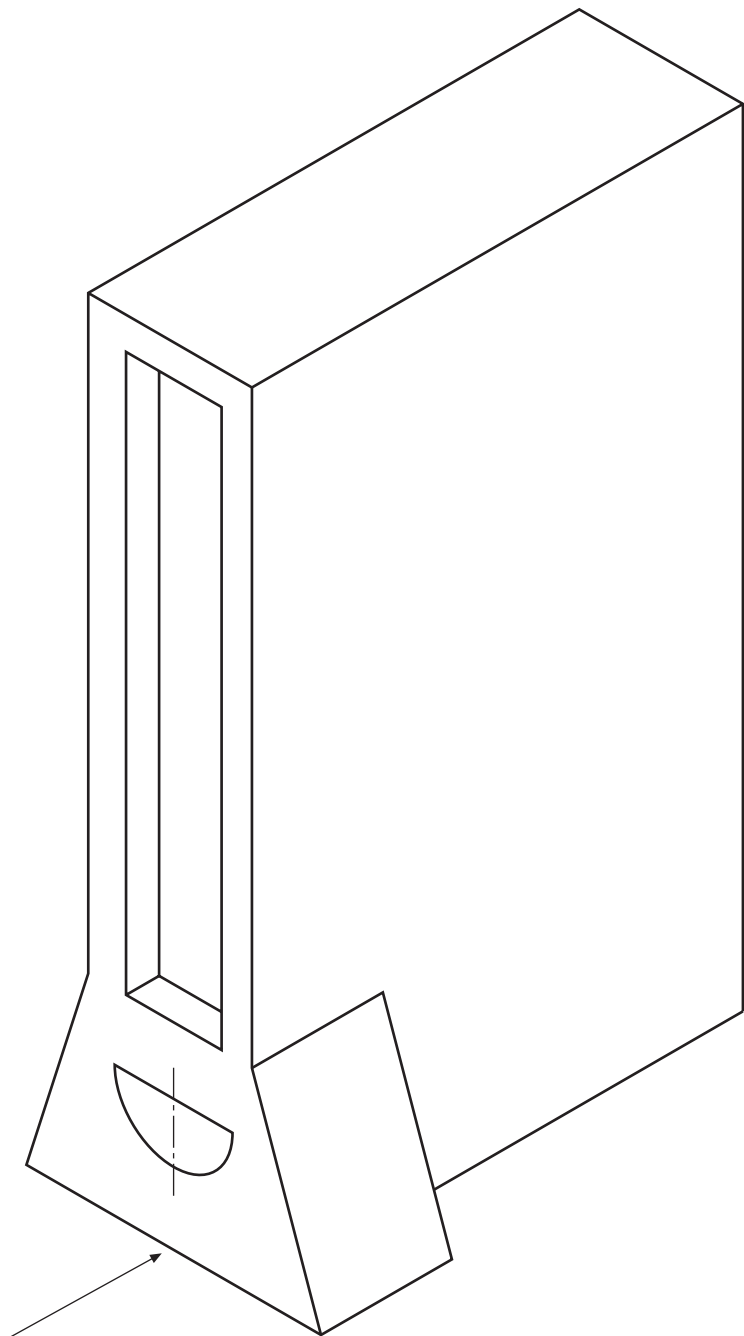

Scale 1:1

<i>a</i>	
<i>b</i>	
<i>c</i>	
<i>d</i>	
<i>e</i>	
<i>f</i>	
<i>g</i>	
<i>h</i>	
<i>i</i>	
<i>j</i>	
<i>k</i>	
<i>l</i>	
<i>m</i>	
<i>n</i>	

Candidate's Name _____

7

The plan, elevation and end elevation of a room with 2 pieces of furniture are given.

Draw, in the position given, the **planometric** view of the room, including the wall thickness.

Do not show hidden detail.
Do not show the door handles.

(10 marks)

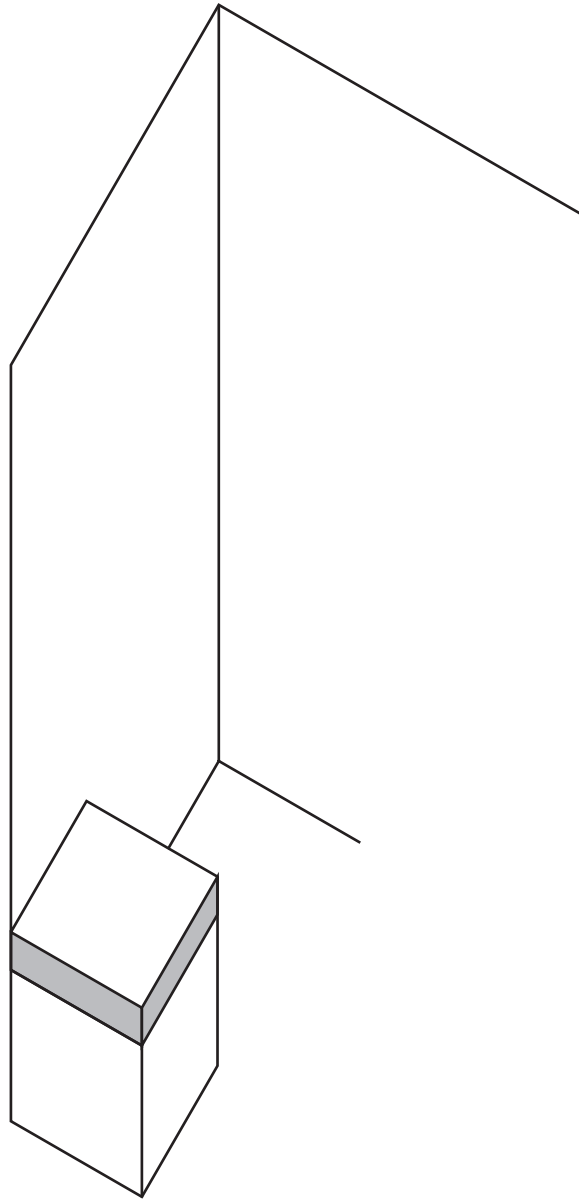

Planometric

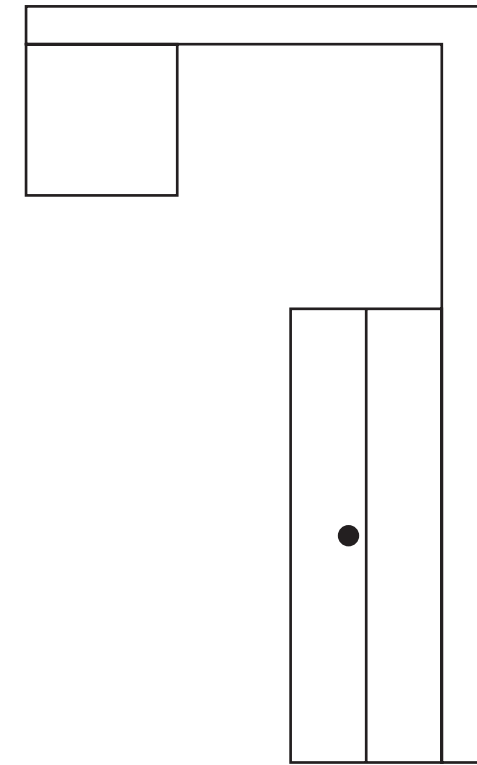

Plan

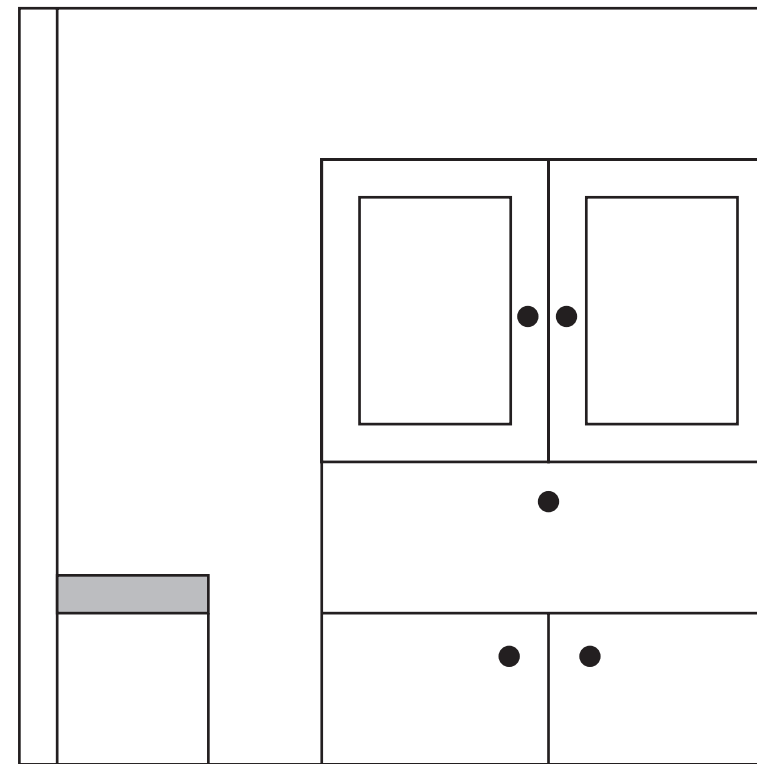

End Elevation

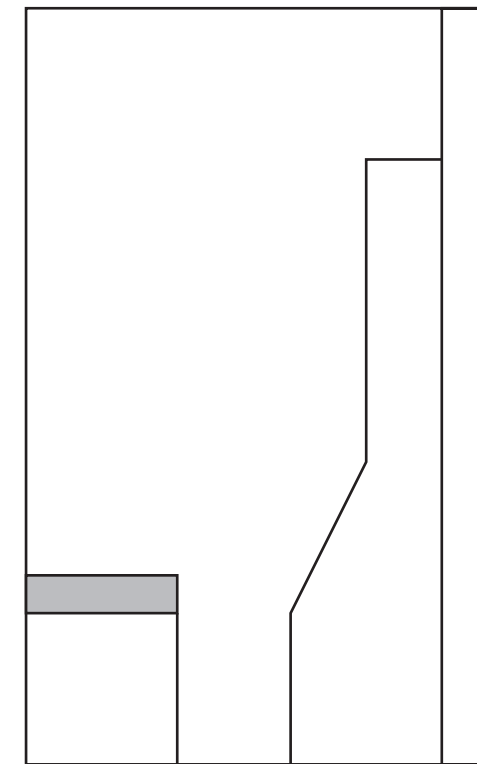

Elevation

<i>a</i>	
<i>b</i>	
<i>c</i>	
<i>d</i>	
<i>e</i>	
<i>f</i>	
<i>g</i>	
<i>h</i>	
<i>i</i>	
<i>j</i>	
<i>k</i>	
<i>l</i>	
<i>m</i>	
<i>n</i>	

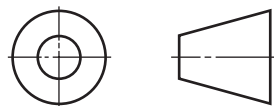

8

The plan and elevation of a chess piece based on a triangular prism are given. An illustration is shown.

Draw, in the positions given:

- (a) the end elevation;
- (b) the development of the sides of the **triangular prism**.

(11 marks)

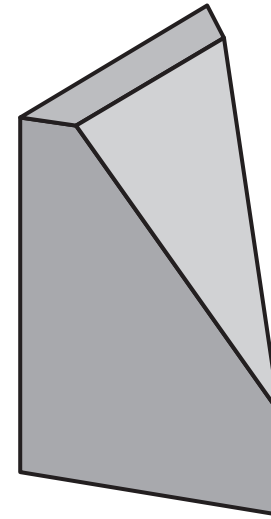

Triangular Prism

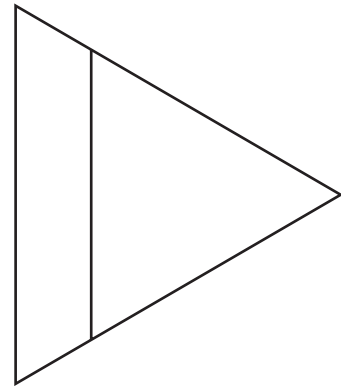

Plan

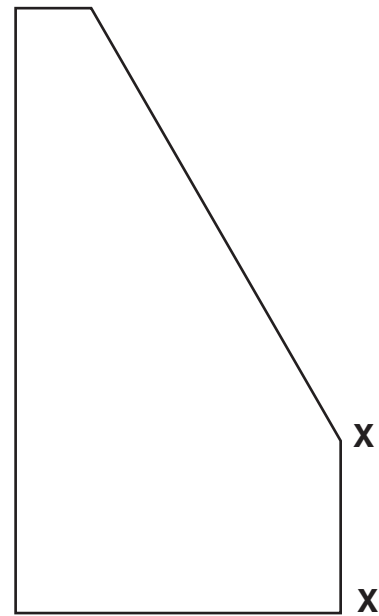

Elevation



End Elevation

Development

<i>a</i>	
<i>b</i>	
<i>c</i>	
<i>d</i>	
<i>e</i>	
<i>f</i>	
<i>g</i>	
<i>h</i>	
<i>i</i>	
<i>j</i>	
<i>k</i>	
<i>l</i>	
<i>m</i>	
<i>n</i>	

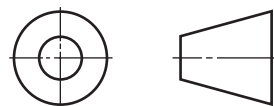

9

The plan and elevation of a round box with a lid are given.

An illustration is shown.

The views are **NOT TO SCALE**.

Draw:

(a) the plan on the given start;

(b) the sectional elevation **A-A**.

Show hidden detail on plan.

(12 marks)

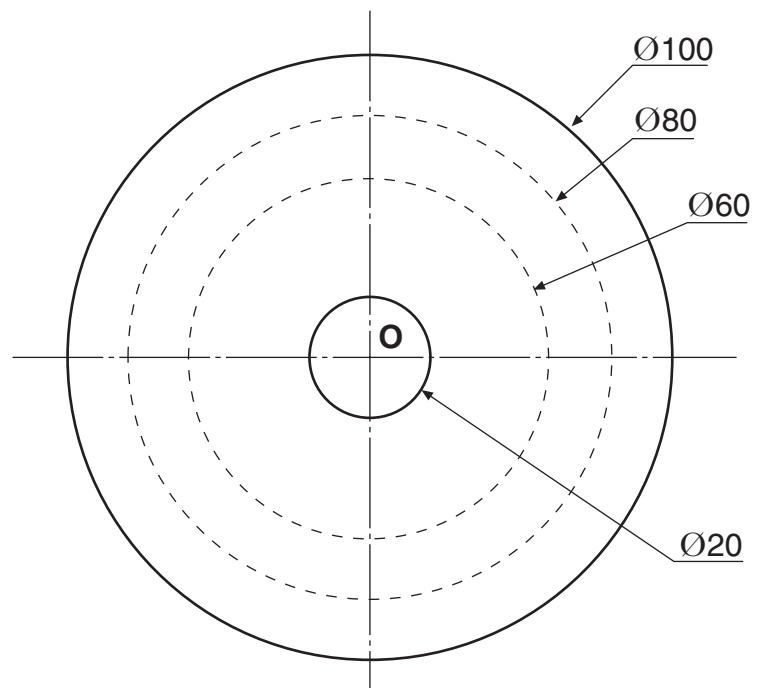
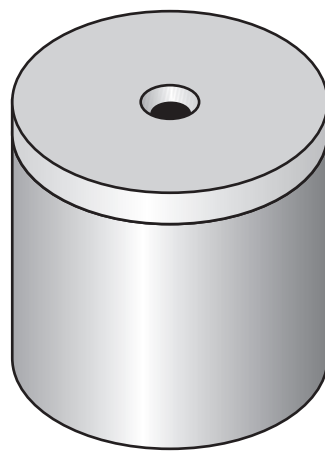

Plan

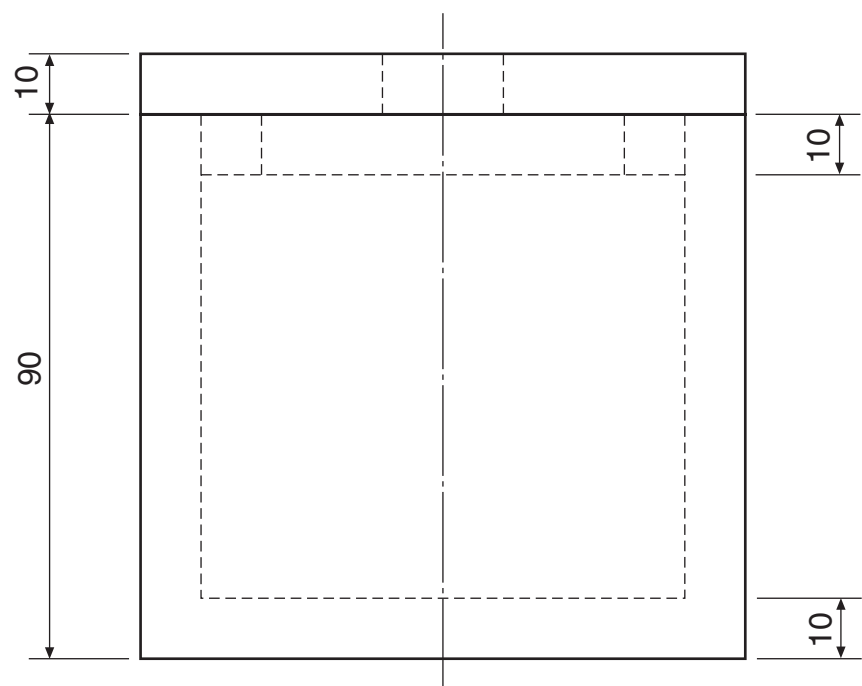

Elevation

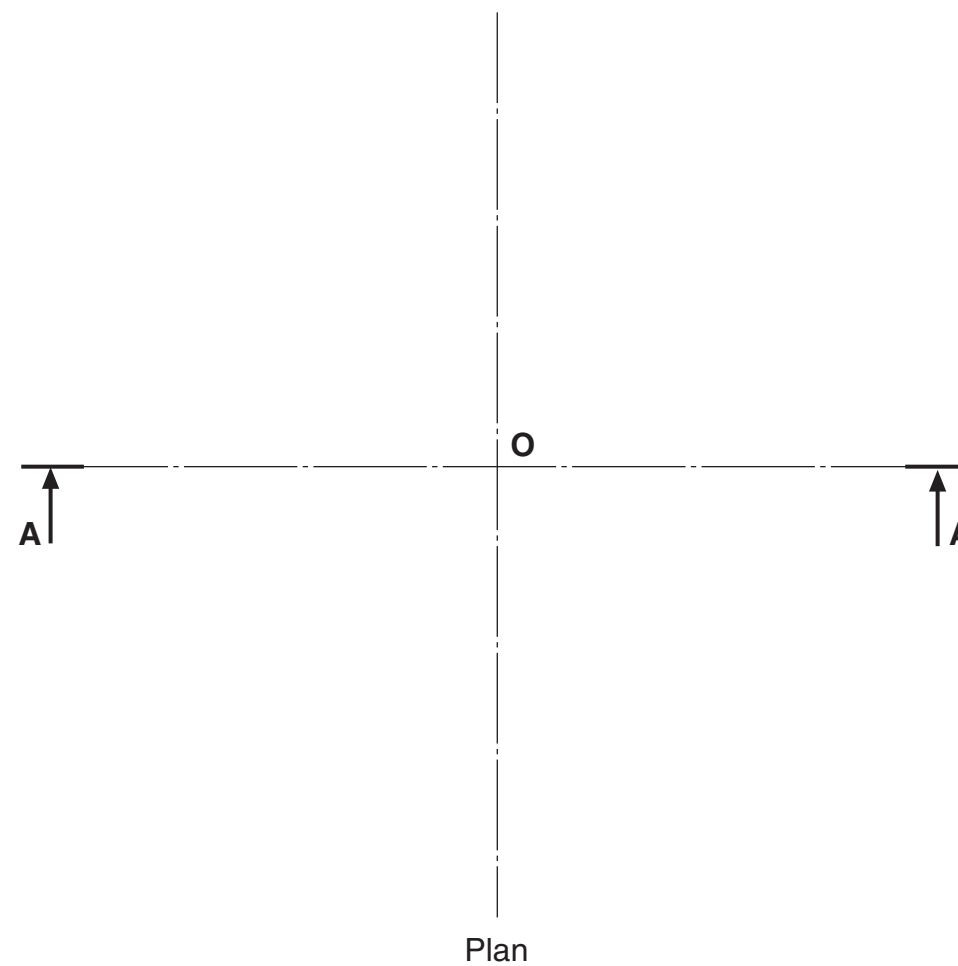

Sectional Elevation A-A

<i>a</i>	
<i>b</i>	
<i>c</i>	
<i>d</i>	
<i>e</i>	
<i>f</i>	
<i>g</i>	
<i>h</i>	
<i>i</i>	
<i>j</i>	
<i>k</i>	
<i>l</i>	
<i>m</i>	
<i>n</i>	

NOT TO SCALE: DO NOT LIFT SIZES FROM VIEWS

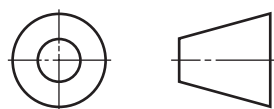

[BLANK PAGE]

[C033/SQP315]

Graphic
Communication
Intermediate 1
Specimen Marking Instructions

NATIONAL
QUALIFICATIONS

Question 1

- | | | |
|-----|--|----------------|
| (a) | Green | 1 |
| (b) | Warm colour – Red, Yellow, Orange | 1 |
| | Cool colour – Blue, Green, Violet | 1 |
| (c) | Brings the graphic presentation to the foreground, it makes it stand out | 1 |
| | Total marks | 4 marks |

Question 2

- | | | |
|-----|--------------------|----------------|
| (a) | Exploded | 1 |
| (b) | Section | 1 |
| | Total marks | 2 marks |

Question 3

- | | | |
|---|--------------------|----------------|
| A | – Hidden | 1 |
| B | – Centre | 1 |
| C | – Outline | 1 |
| D | – Fold | 1 |
| | Total marks | 4 marks |

Question 4

- | | | |
|---|--------------------|----------------|
| A | – Graphics Tablet | 1 |
| B | – Monitor | 1 |
| C | – Mouse | 1 |
| D | – Printer, Inkjet | 1 |
| E | – Scanner | 1 |
| | Total marks | 5 marks |

Question 5

- (a) 14 verticals marked ● **3 marks**
 - 12–14 lines 3 marks
 - 8–11 lines 2 marks
 - 4–7 lines 1 mark

- (b) 13 RH lines marked ◆ **3 marks**
 - 11–13 lines 3 marks
 - 7–10 lines 2 marks
 - 3–6 lines 1 mark

- (c) 13 LH lines marked ✱ **3 marks**
 - 11–13 lines 3 marks
 - 7–10 lines 2 marks
 - 3–6 lines 1 mark

- (d) 3 sloping lines marked ■ **1 mark**
- (e) Correct starting point used **1 mark**
- (f) Correct position of top button and screen **1 mark**

Total 12 marks

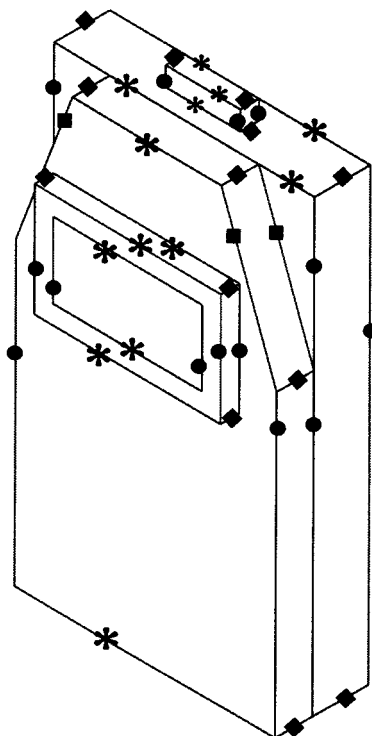

Question 6

- (a) 11 verticals marked ● **3 marks**
 - 10–11 lines 3 marks
 - 6–9 lines 2 marks
 - 2–5 lines 1 mark

- (b) 10 verticals marked ◆ **3 marks**
 - 9–10 lines 3 marks
 - 6–8 lines 2 marks
 - 2–5 lines 1 mark

- (c) 2 sloping marked ✱ **1 mark**

- (d) 5 hidden marked ○ **2 marks**
 - 4–5 lines 2 marks
 - 1–3 lines 1 mark

- (e) Correct hidden linetype **1 mark**

Total 10 marks

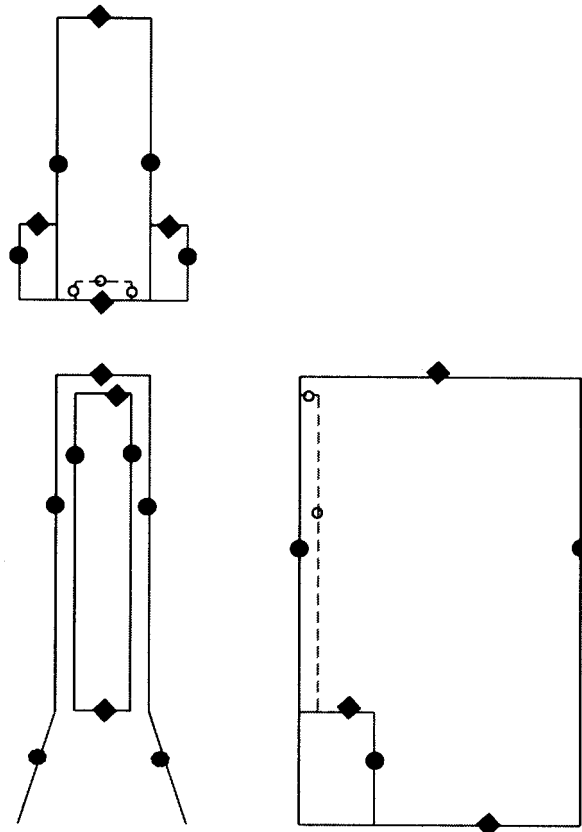

Question 7

- (a) 14 verticals marked ● **4 marks**
12–14 lines 4 marks
9–11 lines 3 marks
6–8 lines 2 marks
3–5 lines 1 mark
- (b) 14 lines @ 30° marked ◆ **4 marks**
12–14 lines 4 marks
9–11 lines 3 marks
6–8 lines 2 marks
3–5 lines 1 mark
- (c) 6 lines @ 60° marked * **1 mark**
3–6 lines 1 mark
- (d) 2 sloping marked ○ **1 mark**

Total 10 marks

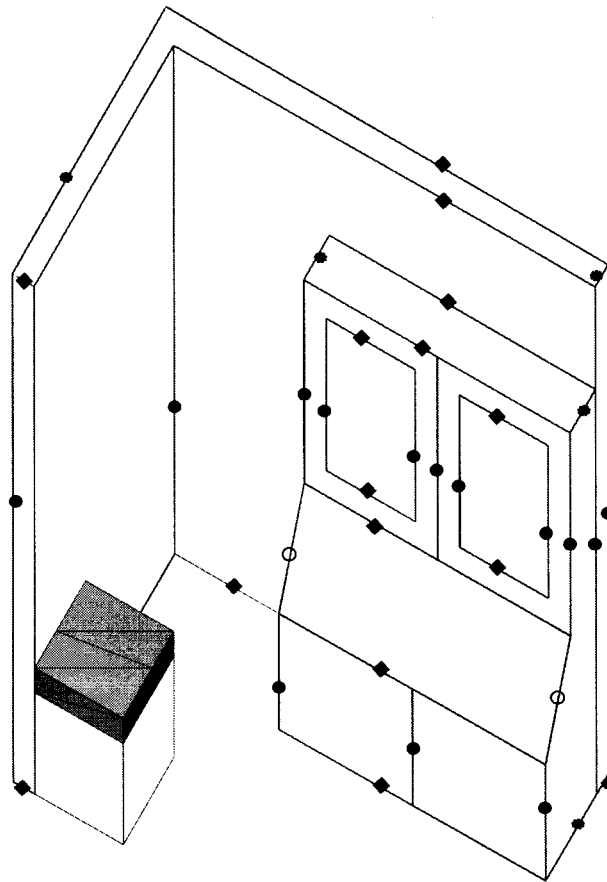

Question 8

End elevation

- (a) 3 verticals marked ● 2 marks
 3 lines 2 marks
 1-2 lines 1 mark
- (b) 2 horizontals marked ◆ 1 mark
- (c) 2 sloping marked ■ 2 marks
 1 line 1 mark

Development

- (d) Correct height 1 mark
- (e) 1 vertical marked ○ 1 mark
- (f) 2 top corners marked ◇ 2 marks
 1 corner 1 mark
- (g) 2 horizontal marked □ 1 mark
- (h) 2 sloping marked * 1 mark

Total 11 marks

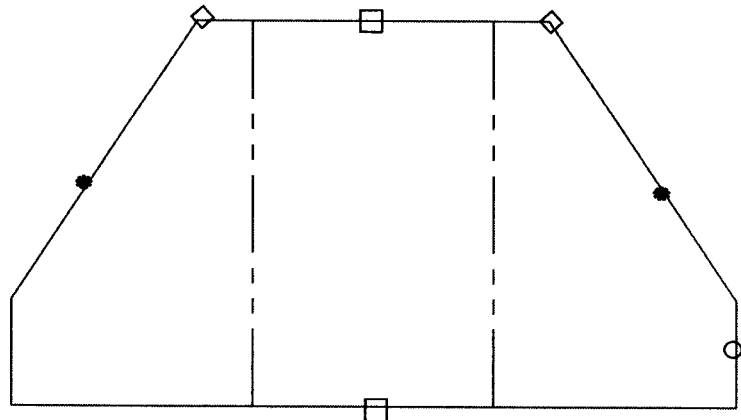
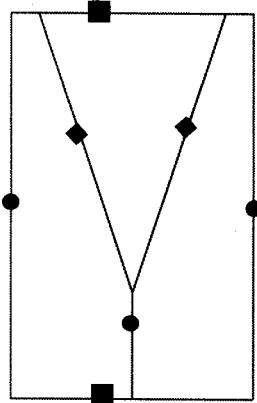

Question 9

Plan

- (a) 2 solid circles marked ○ 2 marks
1 circle 1 mark
- (b) 2 hidden circles marked □ 2 marks
1 circle 1 mark

Sectional Elevation

- (c) 10 verticals marked ● 3 marks
8–10 lines 3 marks
5–7 lines 2 marks
2–4 lines 1 mark
- (d) 7 horizontals marked ◆ 2 marks
5–7 lines 2 marks
2–4 lines 1 mark
- (e) 2 parts treated correctly for Hatching 1 mark
- (f) 45° angle used 1 mark
- (g) Differentiation between sectioned surfaces 1 mark

Total 12 marks

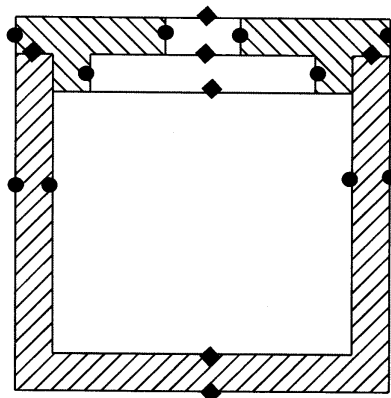
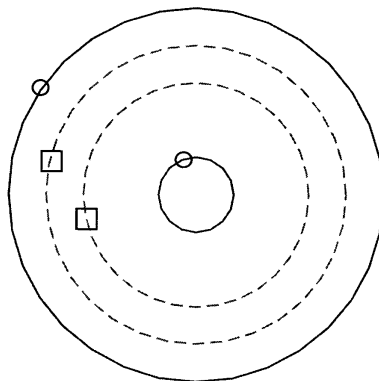

5

The plan, elevation and end elevation of a digital meter are given.

Draw in the position given, the **isometric** view of the meter using starting point **X**.

Do not show hidden detail.

(12 marks)

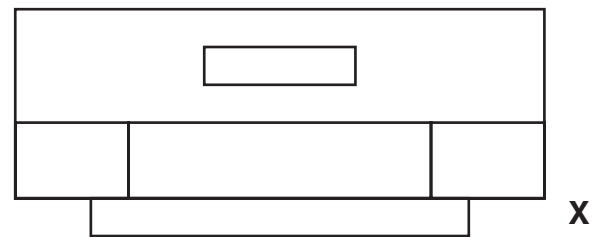

Plan

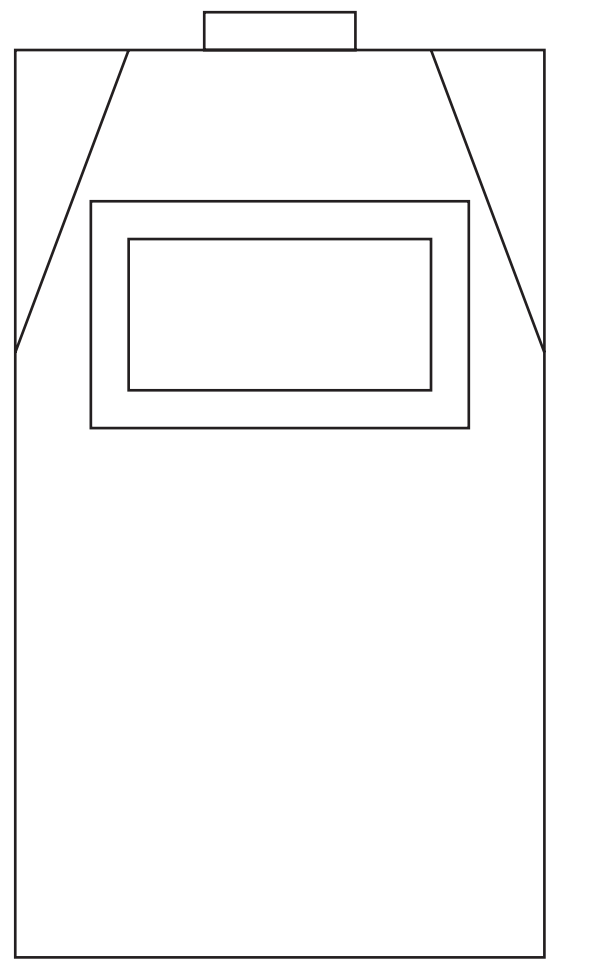

Elevation

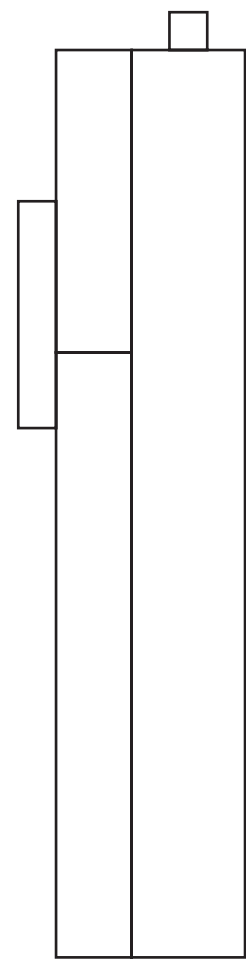

End Elevation

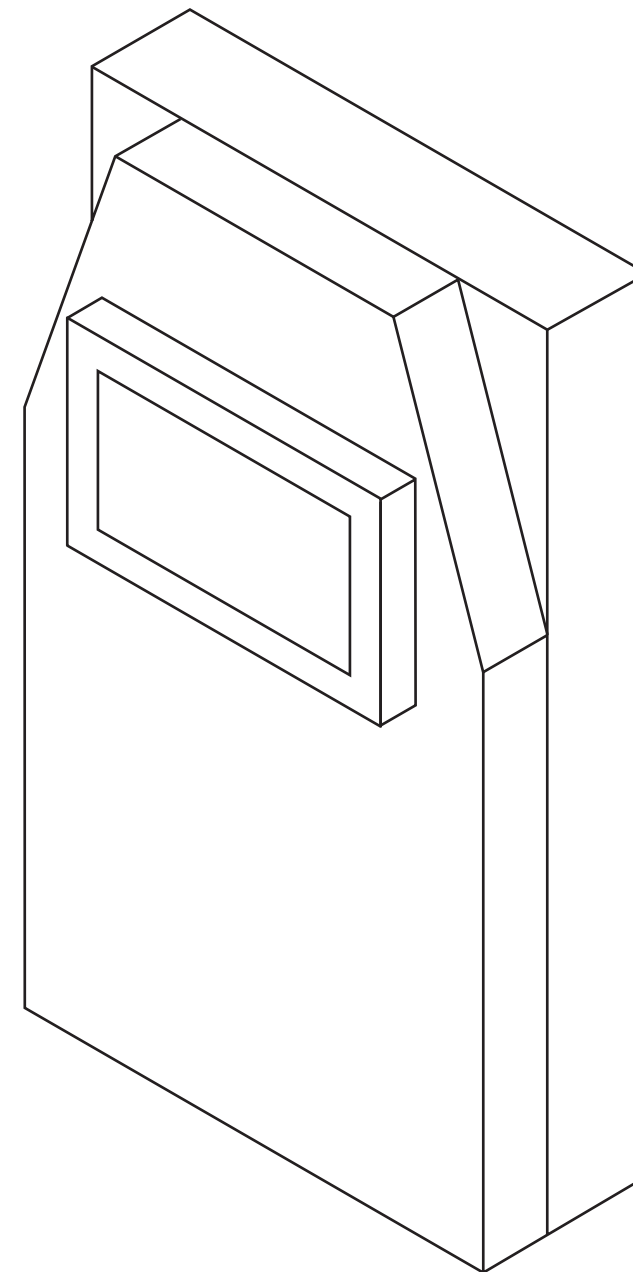

Isometric View

<i>a</i>	
<i>b</i>	
<i>c</i>	
<i>d</i>	
<i>e</i>	
<i>f</i>	
<i>g</i>	
<i>h</i>	
<i>i</i>	
<i>j</i>	
<i>k</i>	
<i>l</i>	
<i>m</i>	
<i>n</i>	

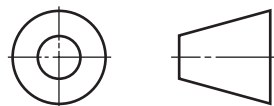

6

An isometric view of a digital TV box is given.

Draw, full size:

- (a) the elevation;
- (b) the plan;
- (c) the end elevation.

(10 marks)

Show all hidden detail.

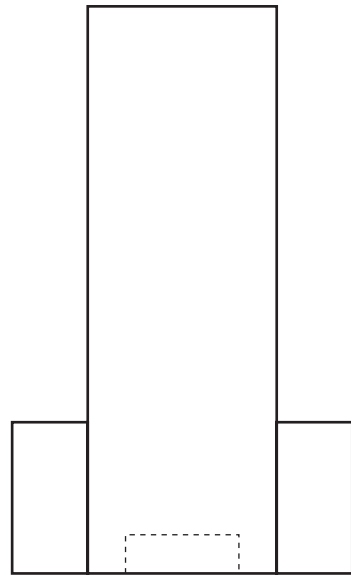

Plan

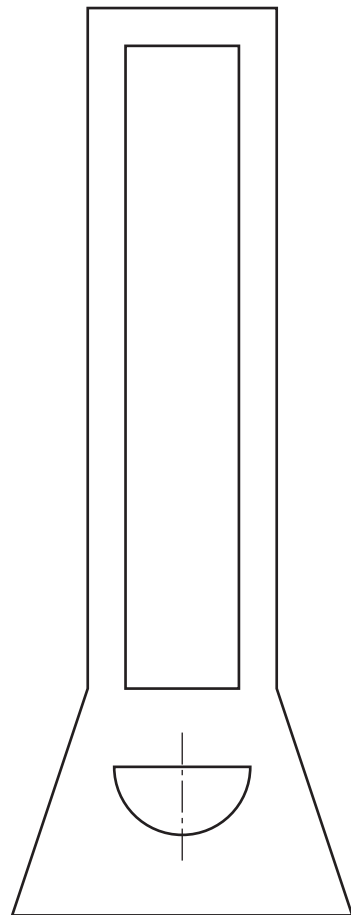

Elevation

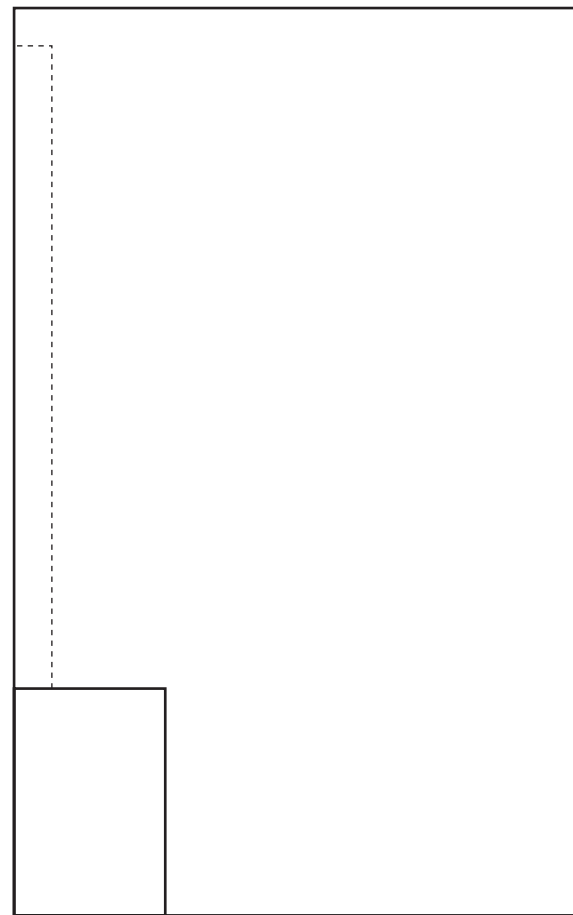

End Elevation

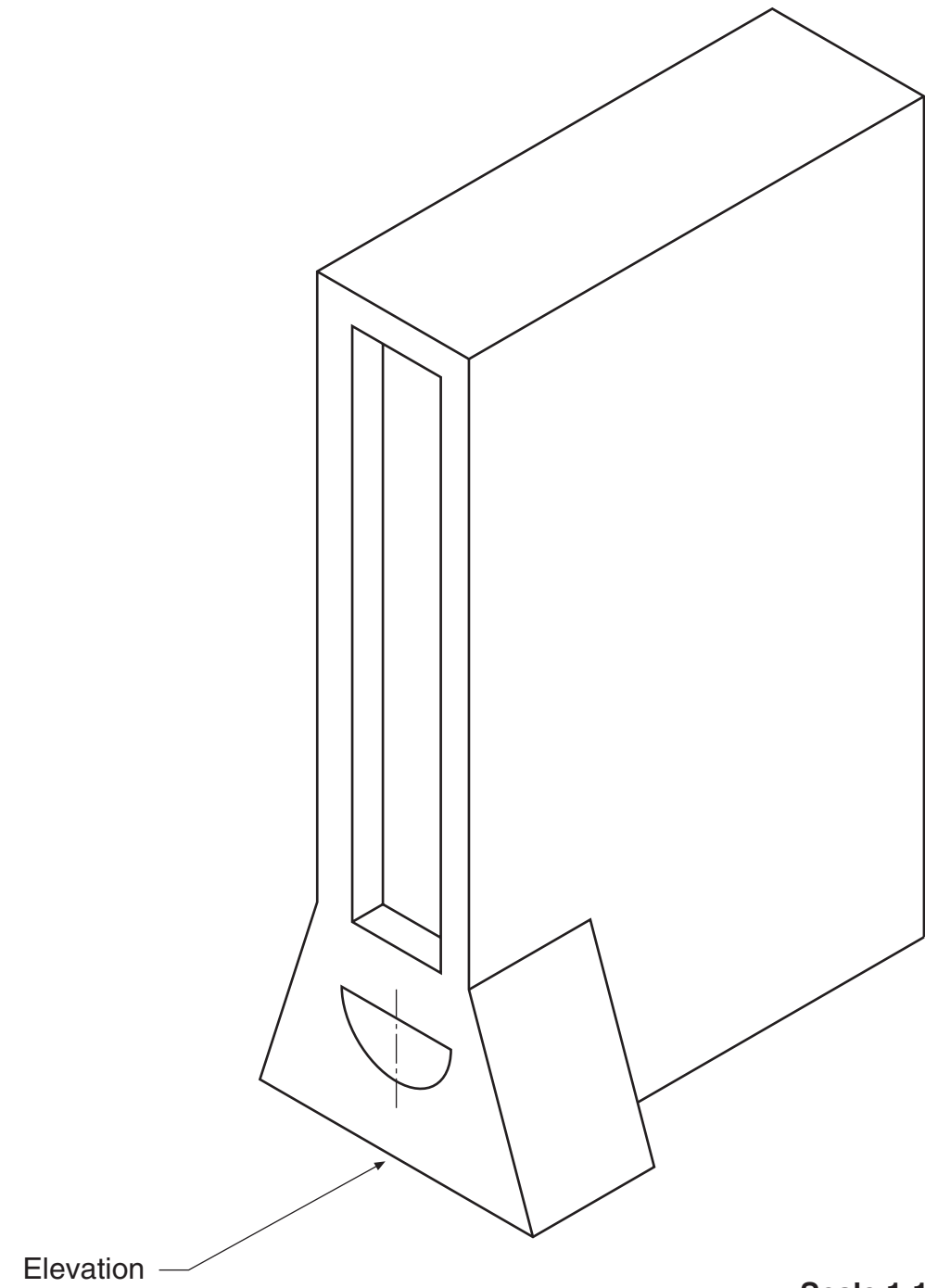
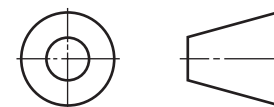

Scale 1:1

<i>a</i>	
<i>b</i>	
<i>c</i>	
<i>d</i>	
<i>e</i>	
<i>f</i>	
<i>g</i>	
<i>h</i>	
<i>i</i>	
<i>j</i>	
<i>k</i>	
<i>l</i>	
<i>m</i>	
<i>n</i>	

Candidate's Name _____

7

The plan, elevation and end elevation of a room with 2 pieces of furniture are given.

Draw, in the position given, the **planometric** view of the room, including the wall thickness.

Do not show hidden detail.
Do not show the door handles.

(10 marks)

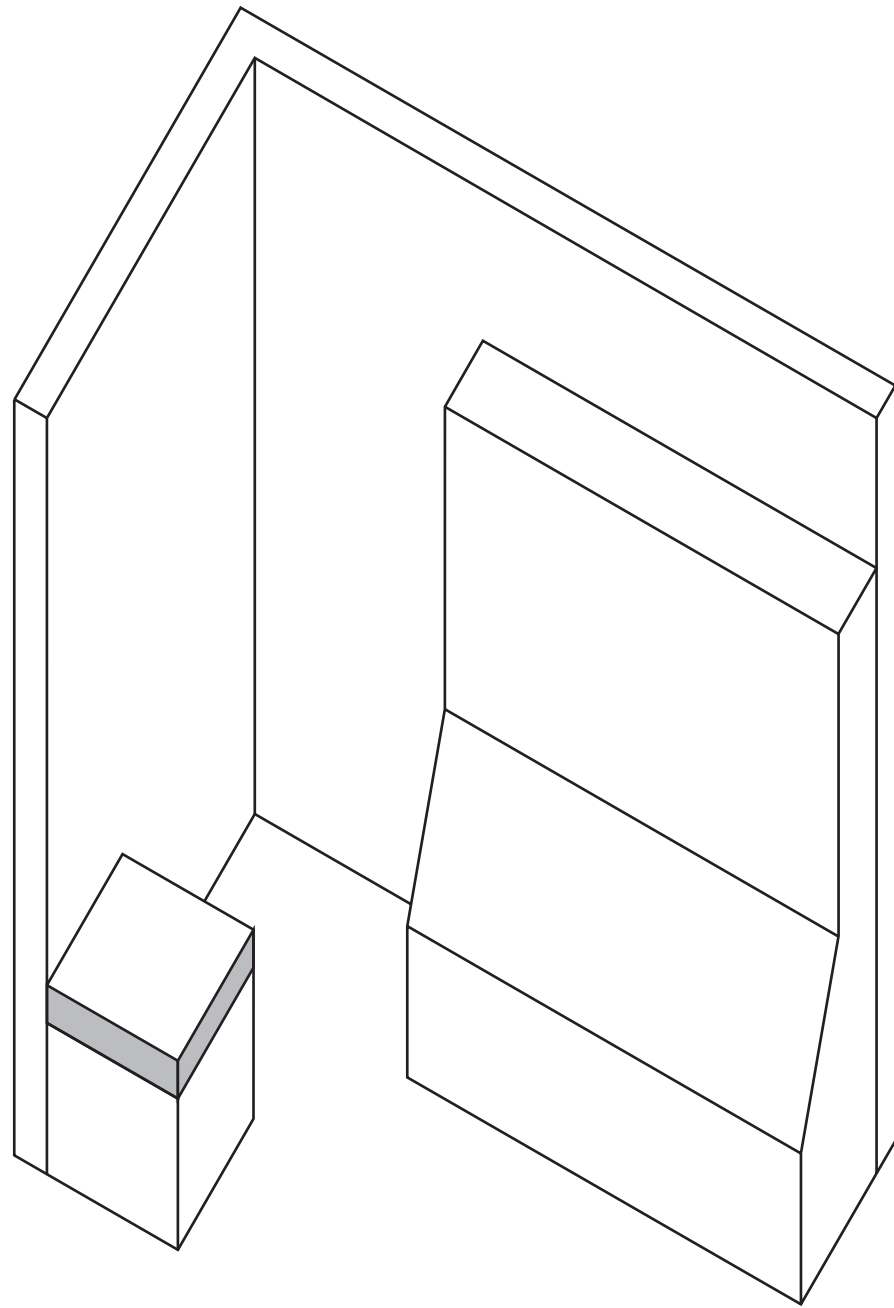

Planometric

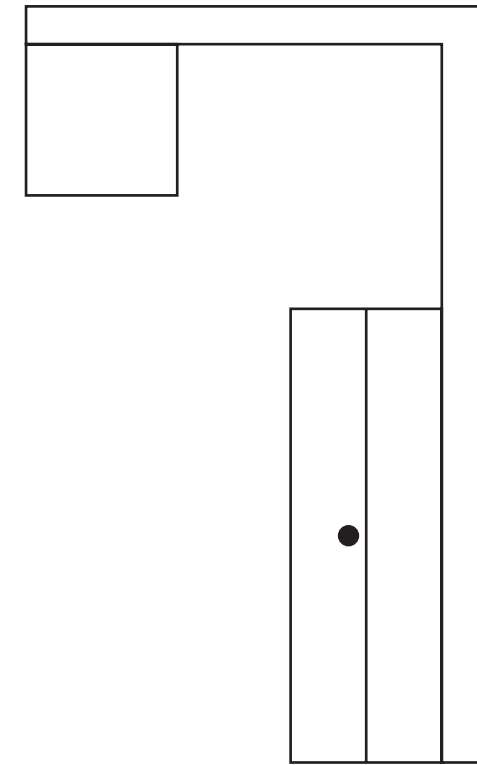

Plan

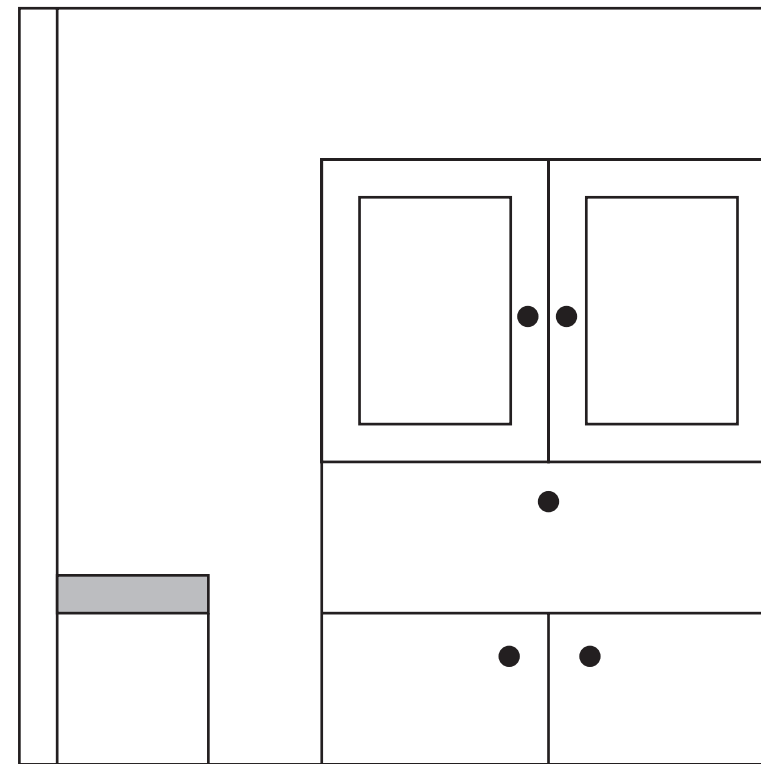

End Elevation

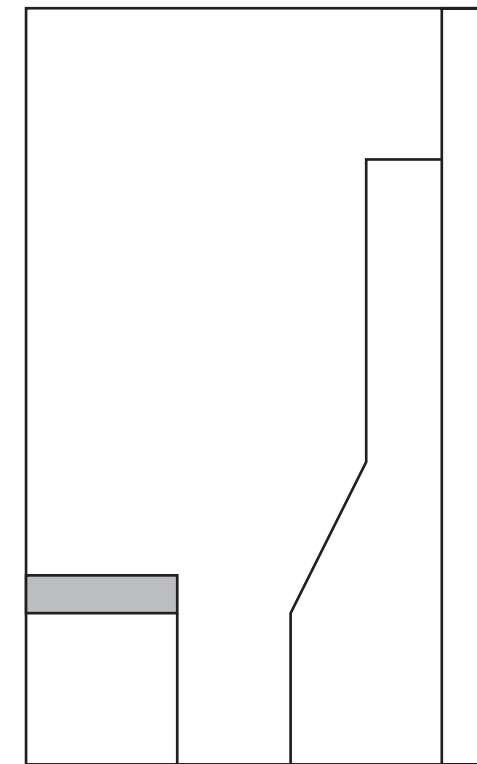

Elevation

<i>a</i>	
<i>b</i>	
<i>c</i>	
<i>d</i>	
<i>e</i>	
<i>f</i>	
<i>g</i>	
<i>h</i>	
<i>i</i>	
<i>j</i>	
<i>k</i>	
<i>l</i>	
<i>m</i>	
<i>n</i>	

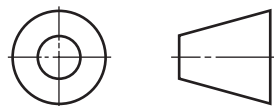

8

The plan and elevation of a chess piece based on a triangular prism are given. An illustration is shown.

Draw, in the positions given:

- (a) the end elevation;
- (b) the development of the sides of the **triangular prism**. (11 marks)

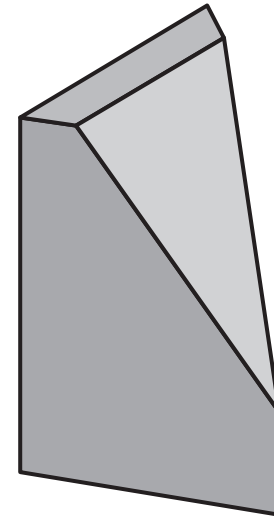

Triangular Prism

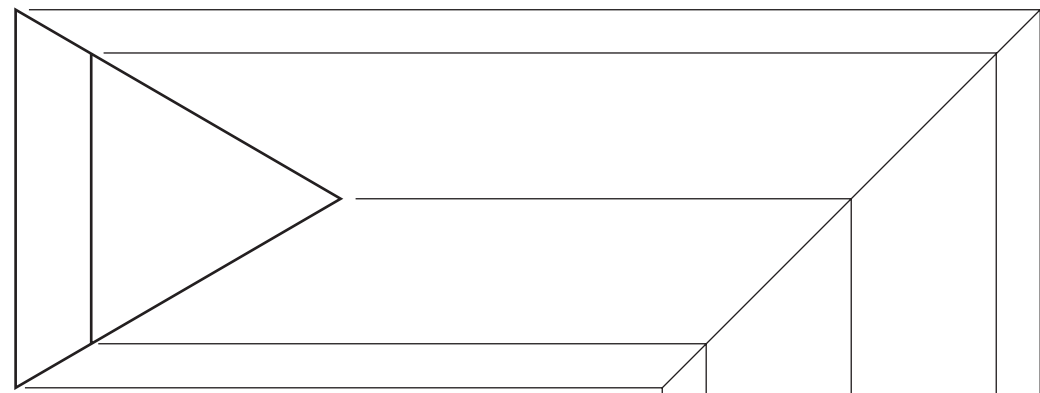

Plan

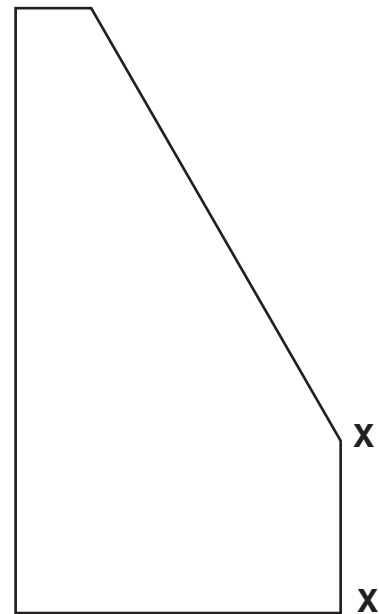

Elevation

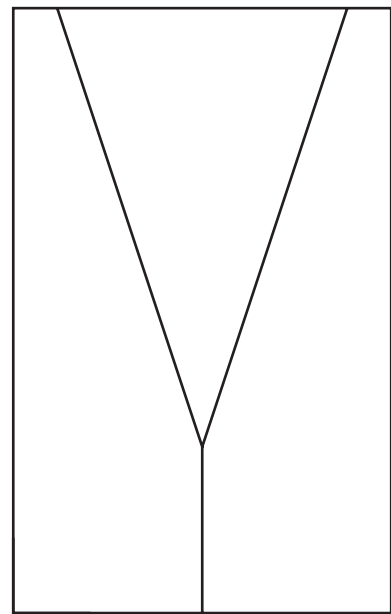

End Elevation

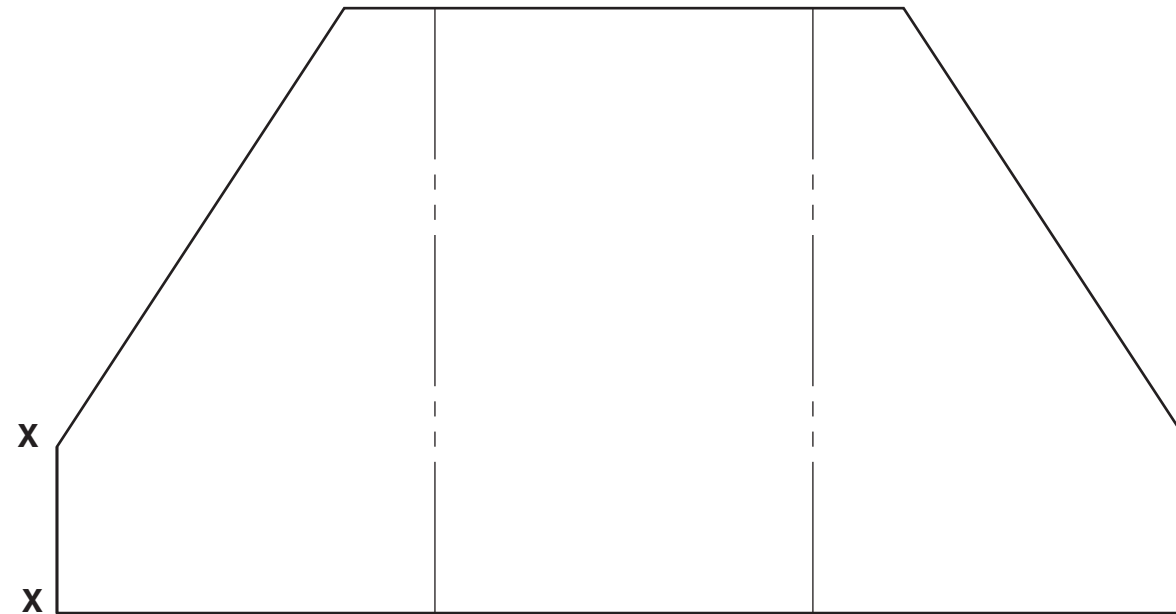

Development

<i>a</i>	
<i>b</i>	
<i>c</i>	
<i>d</i>	
<i>e</i>	
<i>f</i>	
<i>g</i>	
<i>h</i>	
<i>i</i>	
<i>j</i>	
<i>k</i>	
<i>l</i>	
<i>m</i>	
<i>n</i>	

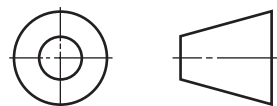

9

The plan and elevation of a round box with a lid are given.

An illustration is shown.

The views are **NOT TO SCALE**.

Draw:

(a) the plan on the given start;

(b) the sectional elevation **A-A**.

Show hidden detail on plan.

(12 marks)

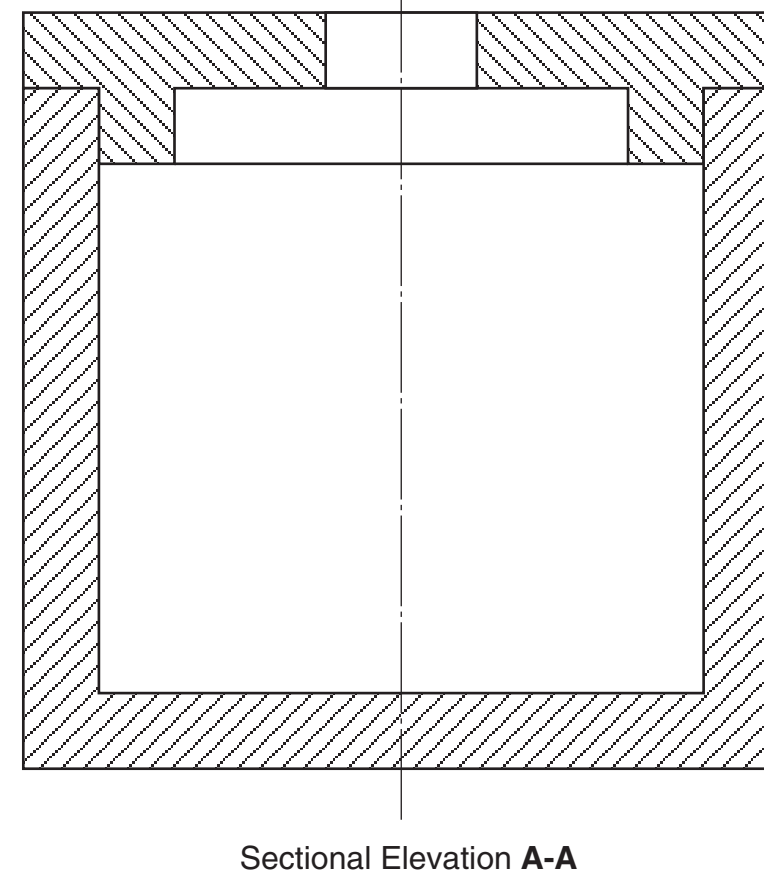
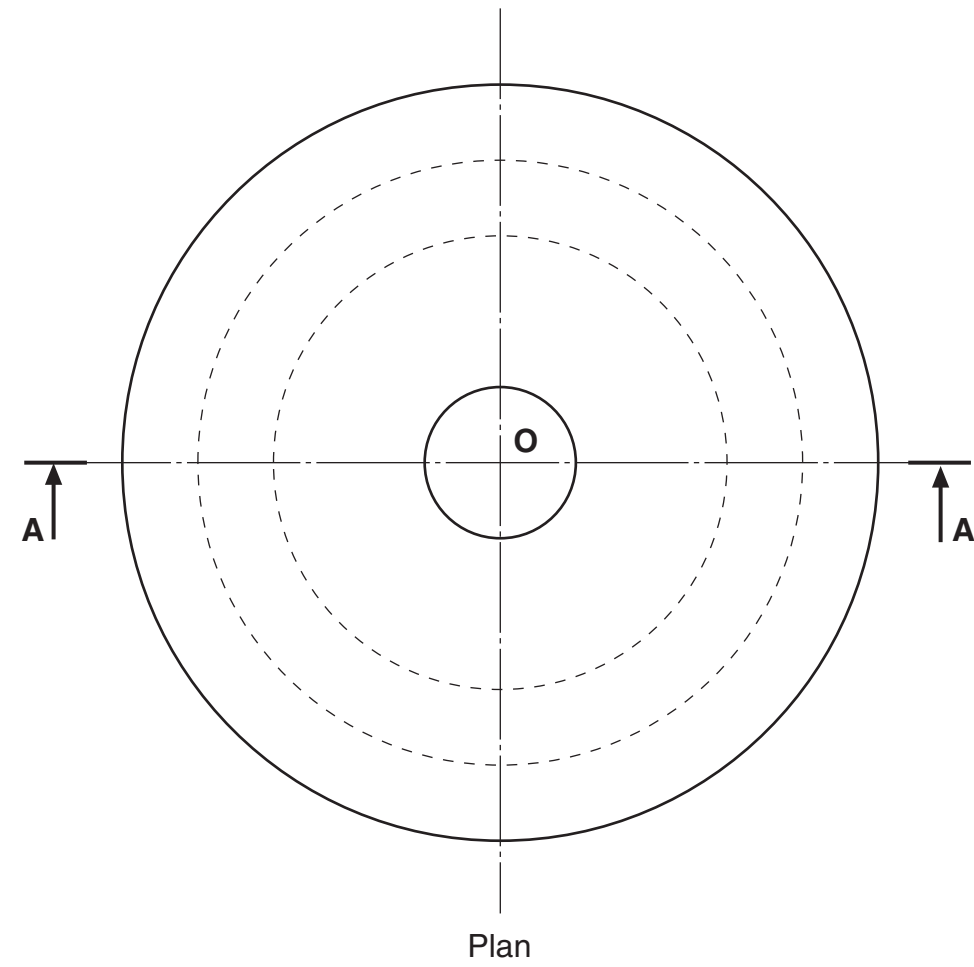
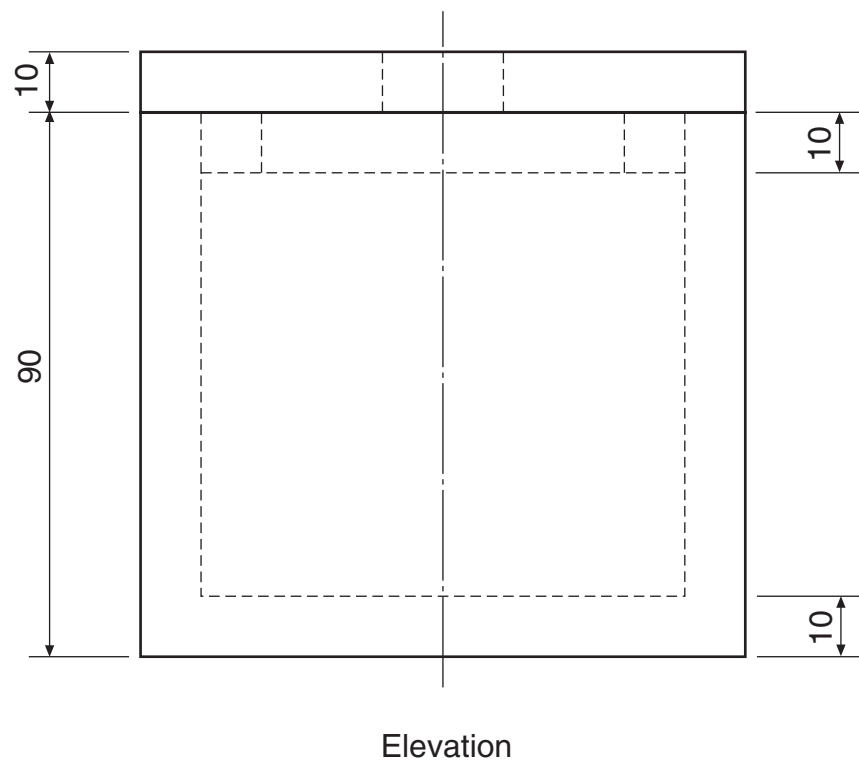
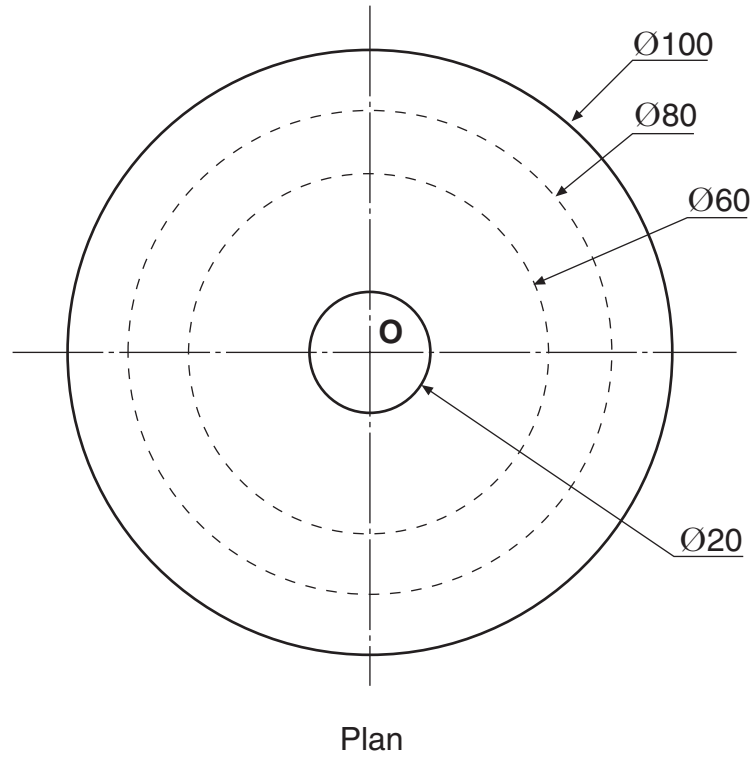
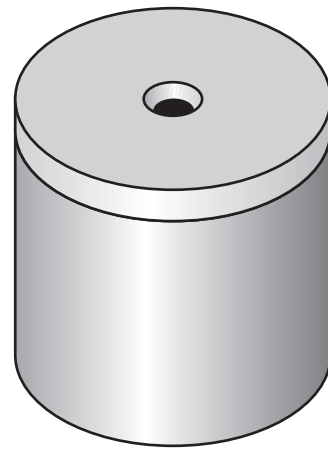

<i>a</i>	
<i>b</i>	
<i>c</i>	
<i>d</i>	
<i>e</i>	
<i>f</i>	
<i>g</i>	
<i>h</i>	
<i>i</i>	
<i>j</i>	
<i>k</i>	
<i>l</i>	
<i>m</i>	
<i>n</i>	

NOT TO SCALE: DO NOT LIFT SIZES FROM VIEWS

