

STAPLE HERE

G

FOR OFFICIAL USE

--	--	--	--	--	--

1330/29/01

NATIONAL THURSDAY, 16 MAY
 QUALIFICATIONS 10.35 AM – 12.05 PM
 2013

GRAPHIC
 COMMUNICATION
 STANDARD GRADE
 General Level

Fill in these boxes and read what is printed below.

Full name of centre			Town		
<input type="text"/>			<input type="text"/>		
Forename(s)			Surname		
<input type="text"/>			<input type="text"/>		
Date of birth					
Day	Month	Year	Scottish candidate number		Number of seat
<input type="text"/>	<input type="text"/>	<input type="text"/>	<input type="text"/>	<input type="text"/>	<input type="text"/>

1 95 marks are allocated to this paper: 35 marks for Knowledge and Interpretation
 60 marks for Drawing Abilities

- 2 Answer all questions.
- 3 Read each question carefully before you answer.
- 4 Written answers may be in **ink** or **pencil**.
- 5 Drawings and sketches **must be in pencil**.
- 6 Sketches need only be in line form—do not spend time rendering.
- 7 Dimensions are given in millimetres or as stated.
- 8 Orthographic drawings are in third angle projection.
- 9 For each question, the element being tested and the mark allocation are shown in brackets, eg (DA 5) means a question on Drawing Abilities worth 5 marks.
- 10 **At the end of the examination**
 - check that your name is on every sheet;
 - put the sheets in correct numerical order;
 - place this sheet on top of the others;
 - join all sheets together by **stapling** at the top left-hand corner;
 - before leaving the examination room, you must give these sheets to the Invigilator (if you do not you may lose all the marks for this paper).

	KI	DA
1		
2		
3		
4		
5		
6		
7		
8		
9		
Total Marks		



[BLANK PAGE]

Colour can be used for many different reasons.

(a) State an appropriate colour to use in the following situations.

(i) To represent something that is safe for the environment.

Colour

(ii) To represent that something is cool.

Colour

(iii) To represent something that is dangerous.

Colour

(iv) To contrast with blue.

Colour

(v) To harmonise with blue.

Colour

KI 5

(b) State the effect created by using a receding colour for the background of a presentation drawing.

Effect

..... KI 1

(c) State what must be added to a primary colour in order to obtain a tertiary colour.

Answer KI 1

(d) State two tertiary colours that contain blue.

Colour Colour KI 2

Total (KI 9)

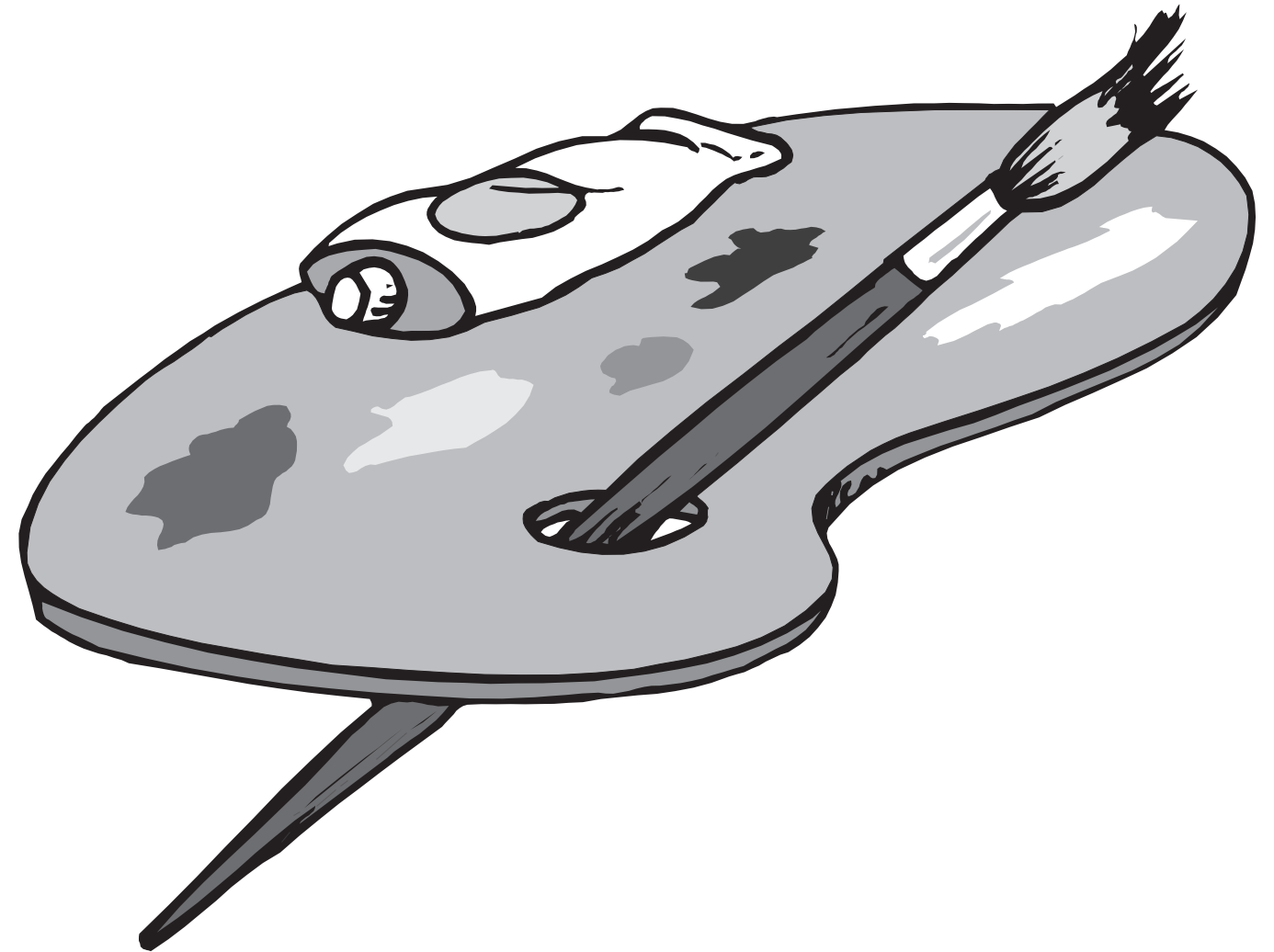

Architects use BSI symbols to represent features on their drawings.

(a) State what each of the architectural symbols shown at **A**, **B**, **C**, **D**, **E**, **F** and **G** represent.

A **B**

C **D**

E **F**

G

KI 7



A



B



C

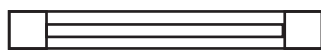

D

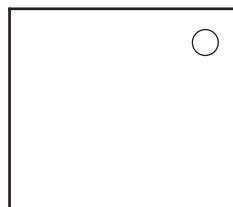

E

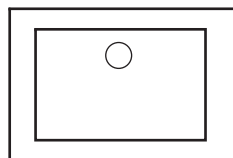

F

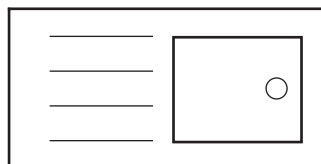

G

(b) Shown below is a plan used by architects.

State the name given to this type of plan.

Name

KI 1

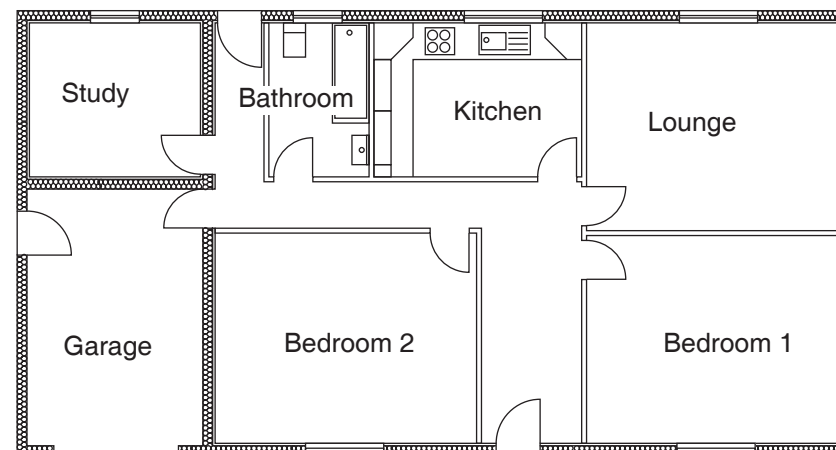

(c) State the names given to two other types of plan commonly used by architects

Plan 1 **Plan 2** KI 2

Total (KI 10)

Study the drawings shown opposite and answer the following questions.

(a) State the names given to the types of views shown at **View P**, **Q**, **R** and **S**.

View P **View Q**

View R **View S** **KI 4**

(b) Explain why the type of view shown in **View P** was a good choice for the view.

Answer

..... **KI 1**

(c) State the angle used at **M** on **View P**.

Angle **M** **KI 1**

(d) State the full name given to points 1 and 2 on **View R**.

Answer **KI 1**

(e) State the name given to line **L** on **View R**.

Line **L** **KI 1**

(f) State the angle used at **N** on **View S**.

Angle **N** **KI 1**

Total (KI 9)

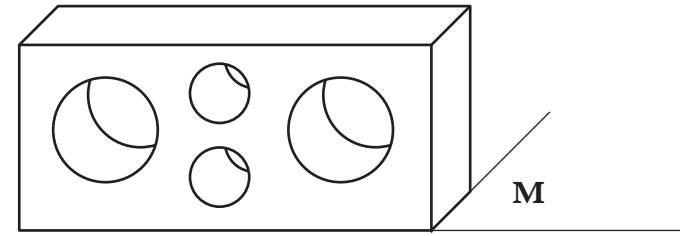

View P

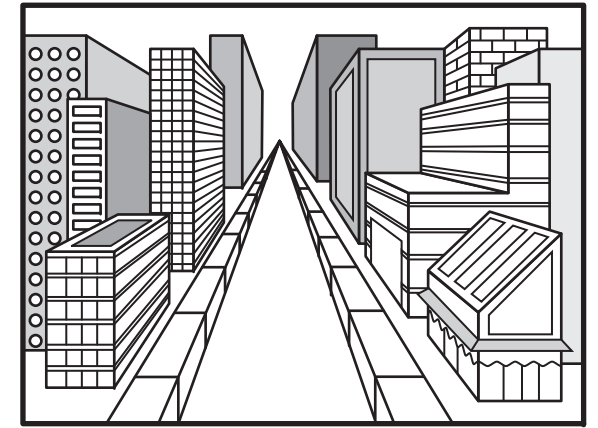

View Q

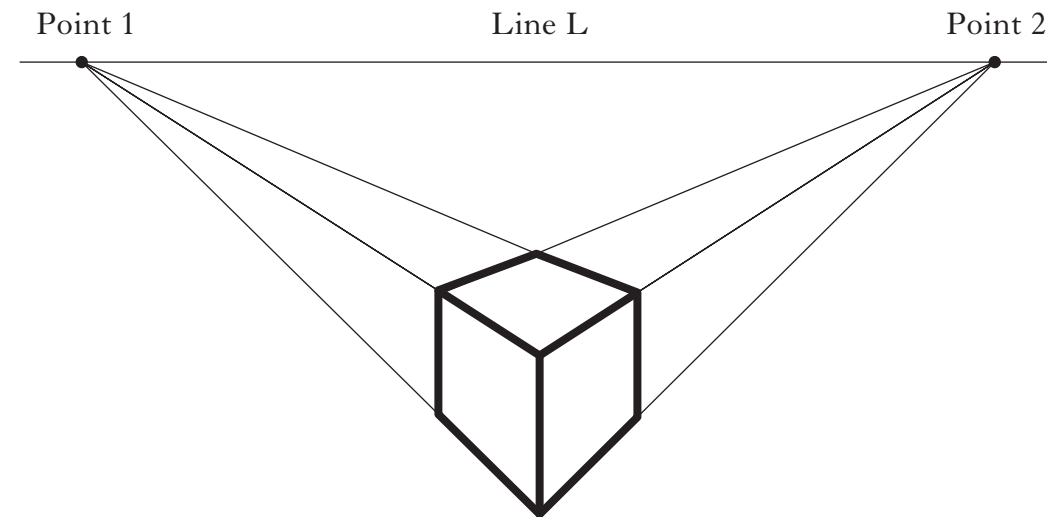

View R

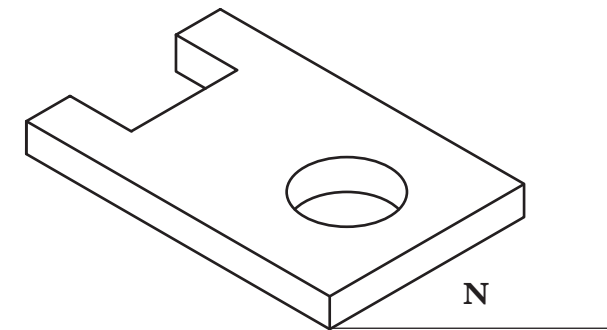

View S

Fill in the missing information about the safety signs given below.

SIGN TYPE



BACKGROUND COLOUR

BORDER COLOUR

None

Wear masks

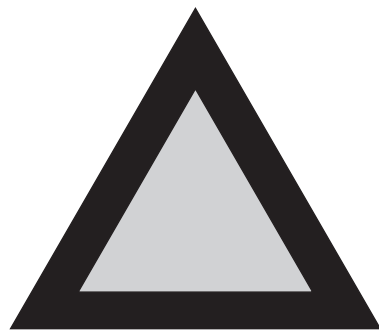

Black

Total (KI 7)

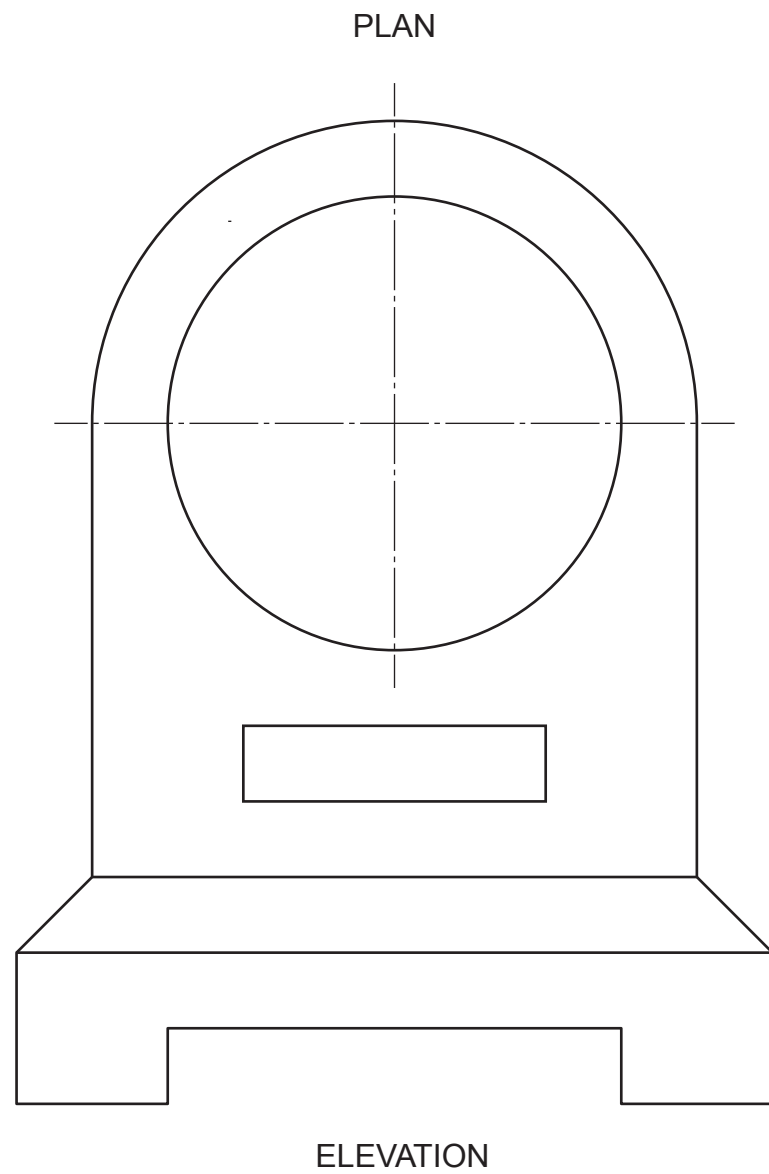

The elevation of a mantel clock is given. A pictorial view is also shown.
 Using the given sizes, **draw**, in the positions indicated:
 (a) the end elevation;
 (b) the plan projected from the elevation.
Show hidden detail.

DA 6
DA 6
Total (DA 12)

a	
b	
c	
d	
e	
f	
g	
h	
i	
j	
k	
l	
m	
n	

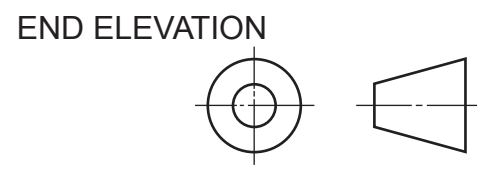
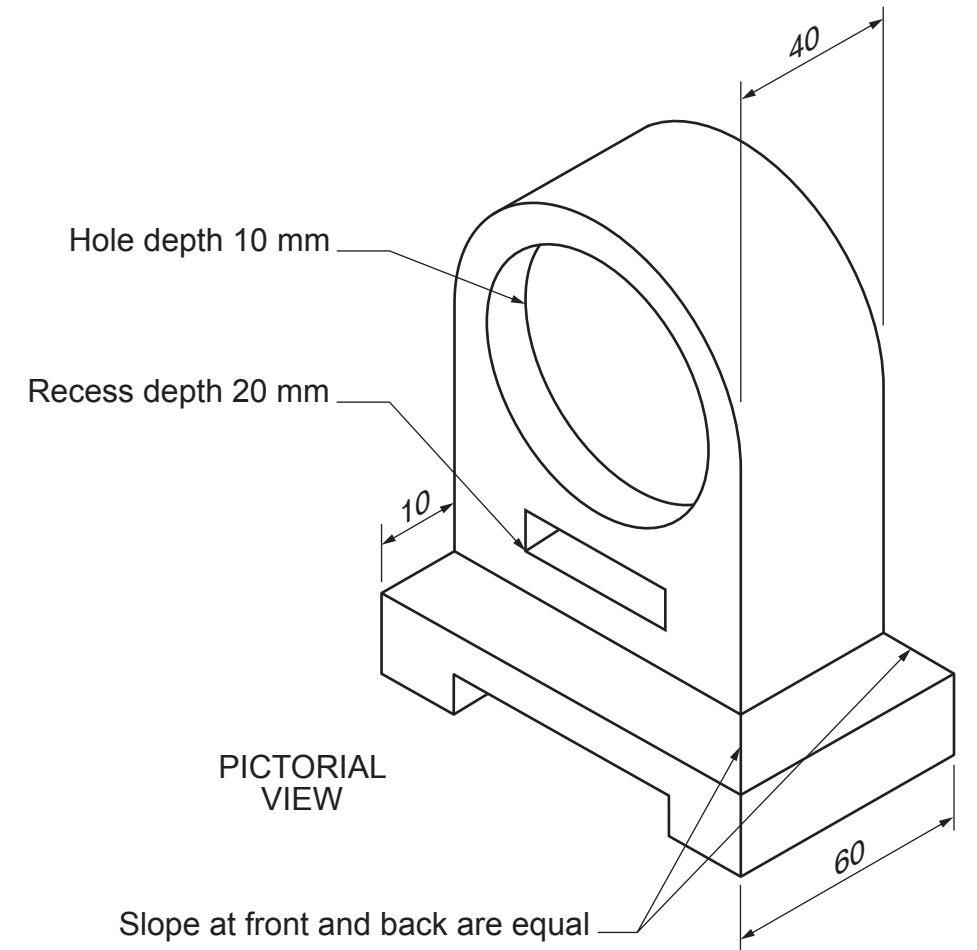

Candidate's Name _____

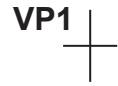

The elevation, end elevation and plan of a static caravan are given.
 Sketch, in good proportion, a two-point perspective view of the static caravan, using points **VP1, VP2** and starting point **X**.

Do not show hidden detail.
A straight edge may be used.

Total (DA 10)

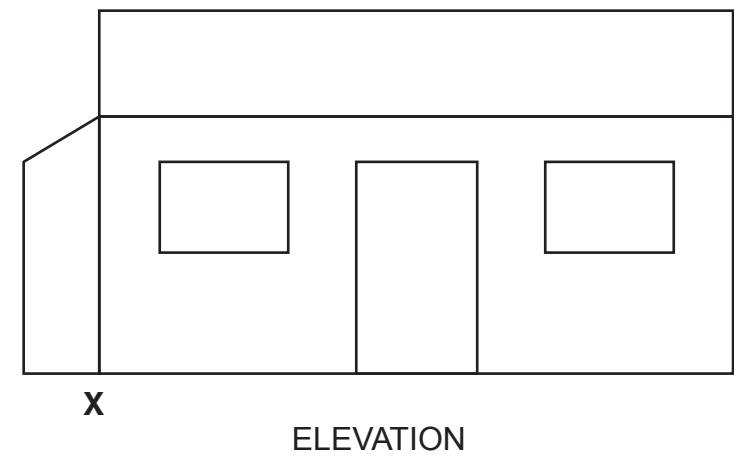
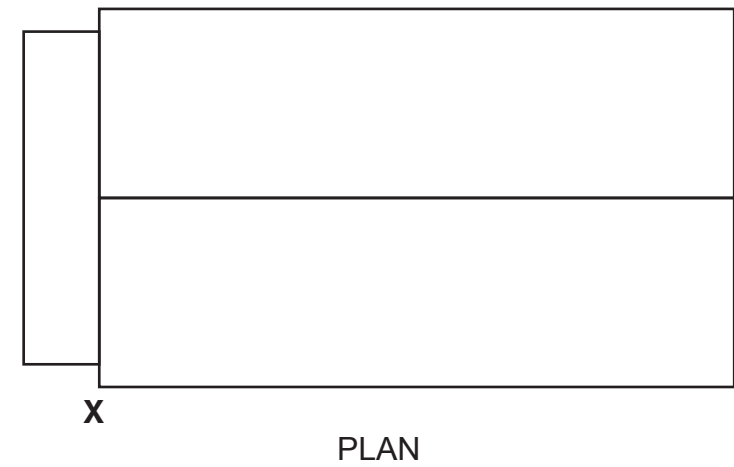
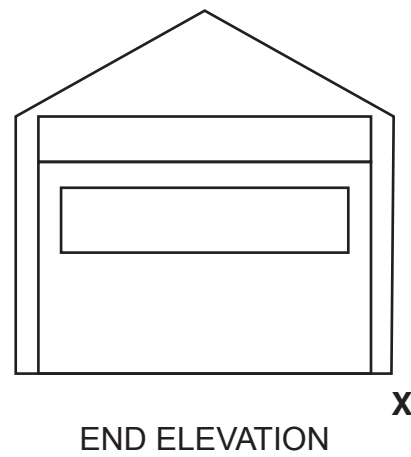

<i>a</i>	
<i>b</i>	
<i>c</i>	
<i>d</i>	
<i>e</i>	
<i>f</i>	
<i>g</i>	
<i>h</i>	
<i>i</i>	
<i>j</i>	
<i>k</i>	
<i>l</i>	
<i>m</i>	
<i>n</i>	

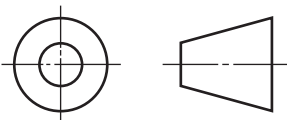

Candidate's Name _____

7

A pictorial view of a cylindrical exhaust for a heating system is shown. The plan and end elevation are given.

Draw in the positions indicated:

(a) the elevation; **DA 6**

(b) the development of the cylindrical exhaust. **DA 8**

Total (DA 14)

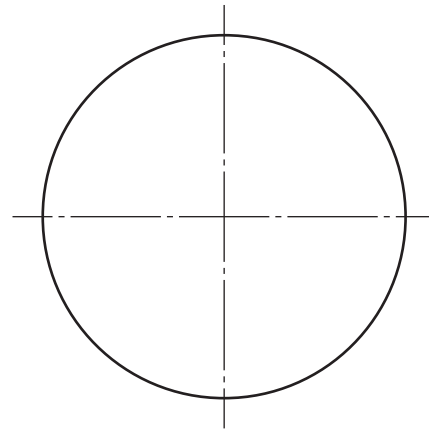

PLAN

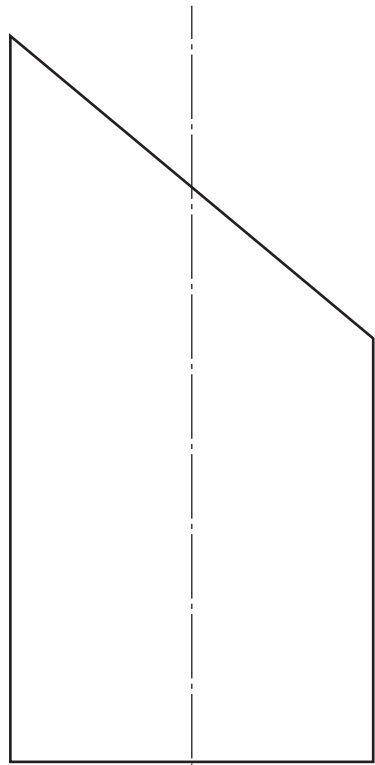

END ELEVATION



ELEVATION



DEVELOPMENT

7

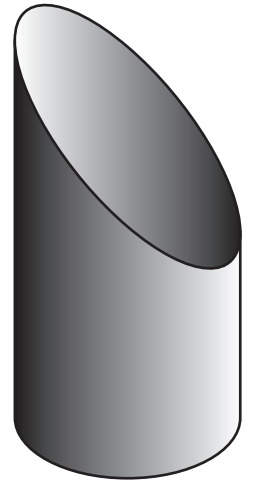

PICTORIAL VIEW

<i>a</i>	
<i>b</i>	
<i>c</i>	
<i>d</i>	
<i>e</i>	
<i>f</i>	
<i>g</i>	
<i>h</i>	
<i>i</i>	
<i>j</i>	
<i>k</i>	
<i>l</i>	
<i>m</i>	
<i>n</i>	

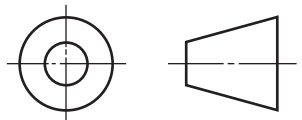

8

The elevation, end elevation and plan of a car radio are given.

Draw an oblique view, using the given start point X.

Do not show hidden detail.

Lines drawn at 45° should be half size. Total (DA 12)

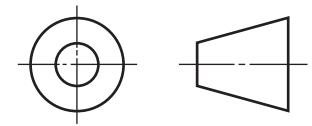

8

a	
b	
c	
d	
e	
f	
g	
h	
i	
j	
k	
l	
m	
n	

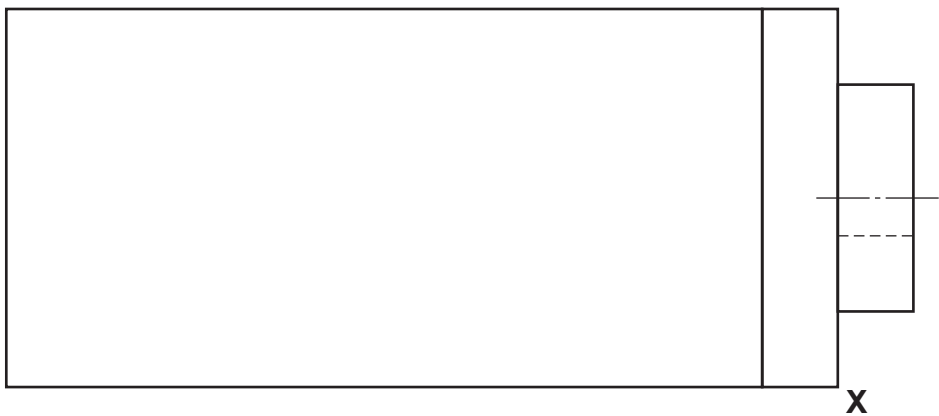
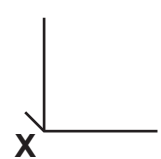

END ELEVATION

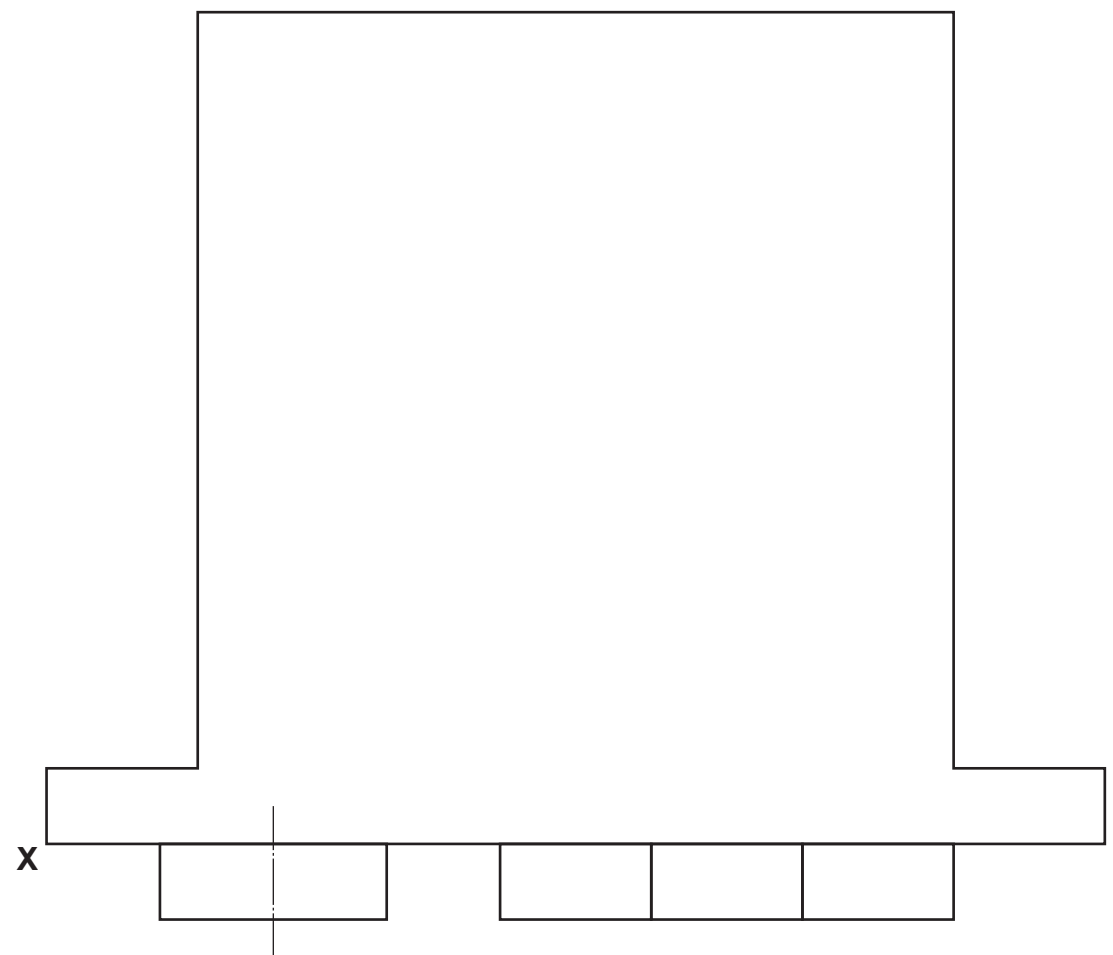

PLAN

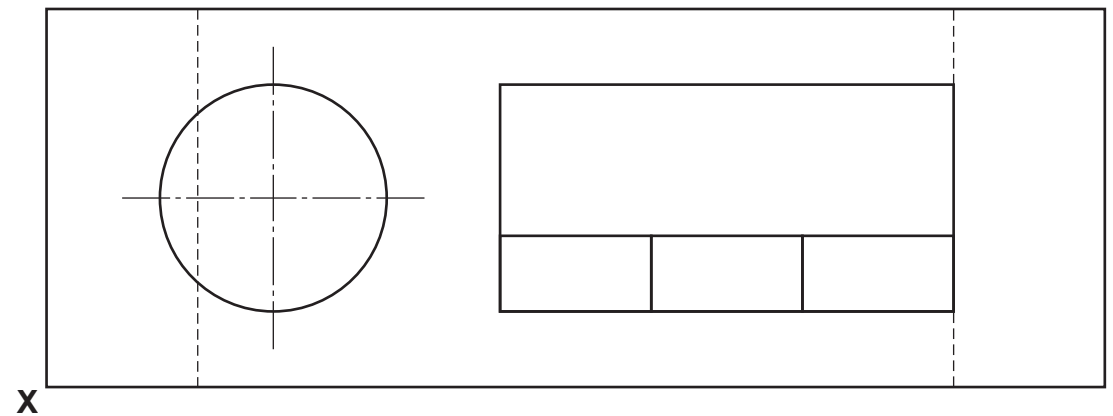

ELEVATION

Candidate's Name _____

The elevation and incomplete plan of a tourist information point in the form of a square based pyramid are given. A pictorial view of the information point is also shown.

Draw in the positions indicated:

- (a) the complete plan;
- (b) the end elevation;
- (c) the true shape of the top surface.

DA 5

DA 4

DA 3

Total (DA 12)

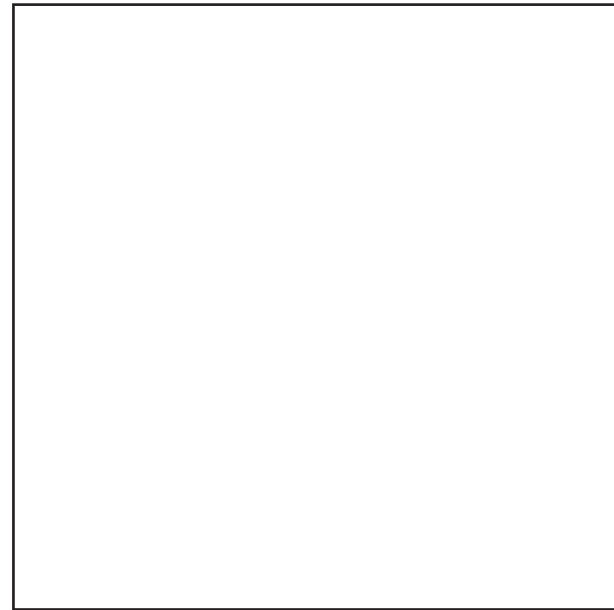

PLAN

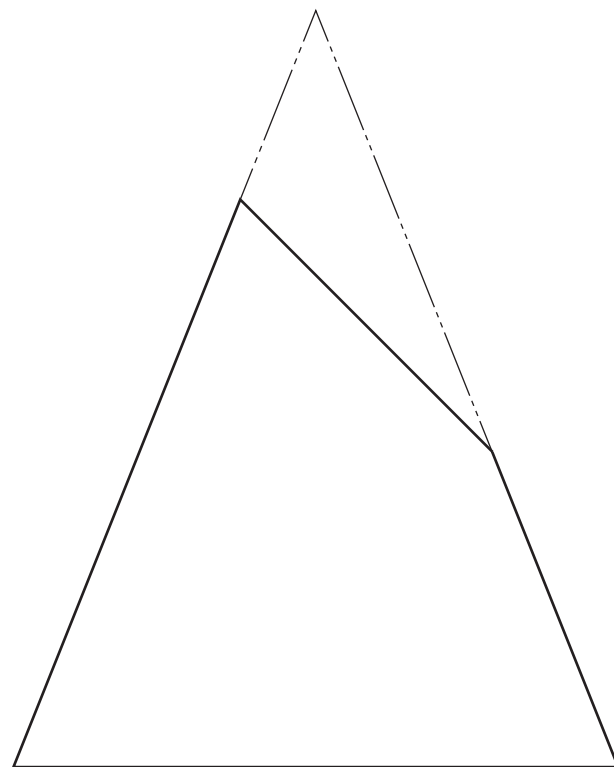

ELEVATION

TRUE SHAPE

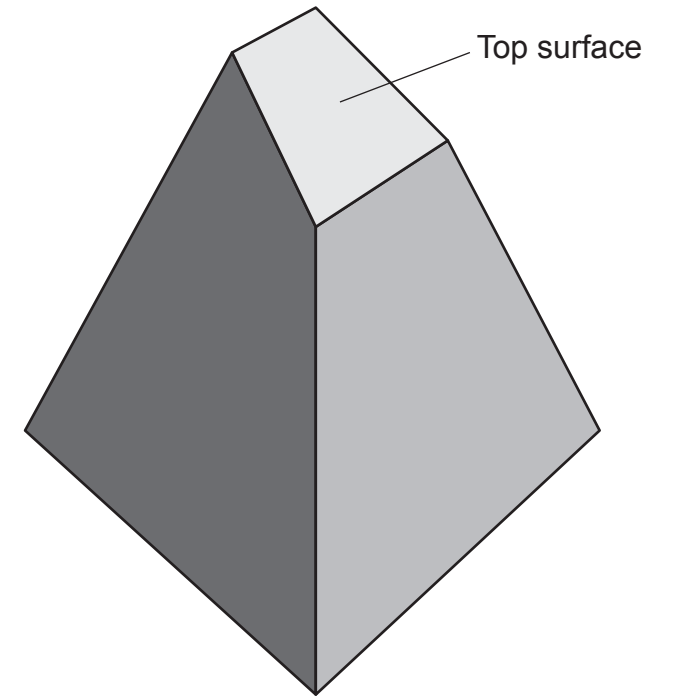

PICTORIAL VIEW

<i>a</i>	
<i>b</i>	
<i>c</i>	
<i>d</i>	
<i>e</i>	
<i>f</i>	
<i>g</i>	
<i>h</i>	
<i>i</i>	
<i>j</i>	
<i>k</i>	
<i>l</i>	
<i>m</i>	
<i>n</i>	

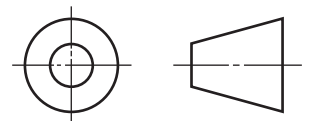

END ELEVATION

Candidate's Name _____

[BLANK PAGE]