

FOR OFFICIAL USE

--	--	--	--	--	--

Total for  
Sections  
B and C

--

**X008/301**

NATIONAL  
QUALIFICATIONS  
2009

FRIDAY, 22 MAY  
1.00 PM – 3.30 PM

BIOTECHNOLOGY  
HIGHER

Fill in these boxes and read what is printed below.

Full name of centre

--

Town

--

Forename(s)

--

Surname

--

Date of birth

Day Month Year

--	--	--	--	--	--	--	--

Scottish candidate number

--	--	--	--	--	--	--	--	--	--

Number of seat

--

**SECTION A (30 marks)**

Instructions for completion of **Section A** are given on page two.  
For this section of the examination you must use an **HB pencil**.

**SECTION B and SECTION C (100 marks)**

- (a) All questions should be attempted.  
(b) It should be noted that in **Section C** questions 1 and 2 each contain a choice.
- The questions may be answered in any order but all answers are to be written in the spaces provided in this answer book, and **must be written clearly and legibly in ink**.
- Additional space for answers will be found at the end of the book. If further space is required, supplementary sheets may be obtained from the invigilator and should be inserted inside the **front** cover of this book.
- The numbers of questions must be clearly inserted with any answers written in the additional space.
- Rough work, if any should be necessary, should be written in this book and then scored through when the fair copy has been written. If further space is required, a supplementary sheet for rough work may be obtained from the invigilator.
- Before leaving the examination room you must give this book to the invigilator. If you do not, you may lose all the marks for this paper.



## SECTION A

### Read carefully

- 1 Check that the answer sheet provided is for **Biotechnology Higher (Section A)**.
- 2 For this section of the examination you must use an **HB pencil** and, where necessary, an eraser.
- 3 Check that the answer sheet you have been given has **your name, date of birth, SCN** (Scottish Candidate Number) and **Centre Name** printed on it.  
Do not change any of these details.
- 4 If any of this information is wrong, tell the Invigilator immediately.
- 5 If this information is correct, **print** your name and seat number in the boxes provided.
- 6 The answer to each question is **either** A, B, C or D. Decide what your answer is, then, using your pencil put a horizontal line in the space provided (see sample question below).
- 7 There is **only one correct** answer to each question.
- 8 Any rough working should be done on the question paper or the rough working sheet, **not** on your answer sheet.
- 9 At the end of the exam, put the **answer sheet for Section A inside the front cover of this answer book**.

### Sample Question

What name is given to a culture of micro-organisms which contains more than one species of organisms?

- A Mixed
- B Pure
- C Simple
- D Complex

The correct answer is **A**—Mixed. The answer **A** has been clearly marked in **pencil** with a horizontal line (see below).

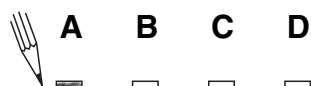

### Changing an answer

If you decide to change your answer, carefully erase your first answer and using your pencil, fill in the answer you want. The answer below has been changed to **D**.



SECTION A

All questions in this Section should be attempted.

1. Which of the following structures is present in both eukaryotic and prokaryotic cells?

- A Lysosome
- B Chloroplast
- C Mitochondrion
- D Ribosome

2. Which line in the table below describes correctly prokaryotic cells?

	<i>Peptidoglycan</i>	<i>DNA</i>
A	In cell wall	Single stranded
B	In cell membrane	Double stranded
C	In cell wall	Double stranded
D	In cell membrane	Single stranded

3. The following steps occur during the replication of a virus.

- 1 alteration of host's biochemistry
- 2 production of viral protein coats
- 3 replication of viral DNA

In which sequence do these events occur?

- A 1 → 3 → 2
- B 1 → 2 → 3
- C 3 → 2 → 1
- D 3 → 1 → 2

4. In the exponential phase of bacterial growth, the population doubles every half hour. If there are 2500 bacteria at the start of this phase, how long will it take to increase the population beyond 1 million?

- A 0.5 hour
- B 4.5 hours
- C 9 hours
- D 45 hours

5. If ten percent of the bases in a molecule of DNA are adenine, what is the ratio of adenine to guanine in the same molecule?

- A 1:1
- B 1:2
- C 1:3
- D 1:4

6. A polypeptide is synthesised on a molecule of mRNA which has 1200 bases. The amino acids in the polypeptide have an average mass of 90 units.

What is the total mass of the polypeptide?

- A 12 000 units
- B 36 000 units
- C 72 000 units
- D 108 000 units

7. Which line in the table below identifies correctly the number of carbon atoms present in each of the named intermediate compounds of respiration?

	<i>Name of compound</i>		
	<i>Acetyl group</i>	<i>Pyruvic acid</i>	<i>Citric acid</i>
A	2	3	6
B	2	3	3
C	4	6	3
D	4	6	6

8. The base sequence of a short piece of DNA is shown below.

A G C T T A C G

During replication, an inversion mutation occurs on the complementary strand synthesised on this piece of DNA.

Which of the following is the mutated complementary strand?

- A T C G A A T G A
- B A G C T T A G C
- C T C G A A T C G
- D T C G A A T G C

9. The Jacob Monod model of gene expression involves the following steps.

- W Gene expression
- X Exposure to inducer
- Y Removal of inhibition
- Z Binding to repressor

The correct order of these steps is

- A Z X Y W
- B W Z X Y
- C Z W X Y
- D X Z Y W.

10. Which of the following identifies correctly the requirements to produce complementary DNA (cDNA)?

- A mRNA template, DNA nucleotides, ATP and reverse transcriptase
- B DNA template, RNA nucleotides, ATP and reverse transcriptase
- C mRNA template, DNA nucleotides, ATP and endonuclease
- D DNA template, RNA nucleotides, ATP and endonuclease

11. A humoral response is best described as

- A a response by T lymphocytes to foreign antigens
- B a response by B lymphocytes to foreign antigens
- C the production of antibodies by T lymphocytes
- D the production of antigens by B lymphocytes.

12. The role of lysosomes within phagocytes is to

- A store enzymes which destroy bacteria
- B neutralise bacterial toxins
- C produce antibodies in response to bacterial antigens
- D engulf bacteria.

13. An investigation was carried out to find out if a disinfectant was biocidal or biostatic to a species of bacteria.

Which line in the table below identifies correctly the results obtained with a biocidal disinfectant?

	<i>Growth in Nutrient Agar</i>	<i>Growth in medium containing disinfectant</i>	<i>Growth in medium after exposure to disinfectant</i>
A	yes	no	no
B	yes	no	yes
C	no	no	no
D	yes	yes	yes

14. Bacteriophages are diluted, mixed with a bacterial broth culture, transferred to an agar plate and incubated.

The technique being described is

- A bacterial lawn preparation
- B viable count
- C total count
- D plaque assay.

15. A mass of unorganised plant cells growing on an agar medium is called a

- A meristem
- B callus
- C colony
- D tissue.

16. The effect of auxin on the growth of a plant tissue culture was investigated. The results are shown in the graph below.

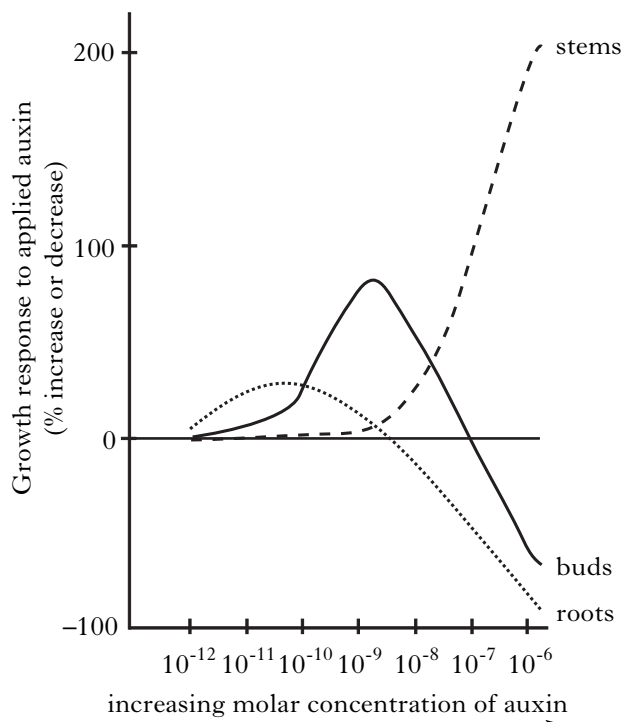

What conclusion can be drawn from this graph?

- A Stems increase in size as auxin concentration decreases.
- B Roots increase in size as auxin concentration increases.
- C At auxin concentrations less than  $10^{-9}$  M stems and roots increase in size but buds decrease.
- D At auxin concentrations greater than  $10^{-9}$  M stems increase in size but buds and roots do not.

**[Turn over**

17. The key below identifies some Gram negative rods on the basis of biochemical tests.

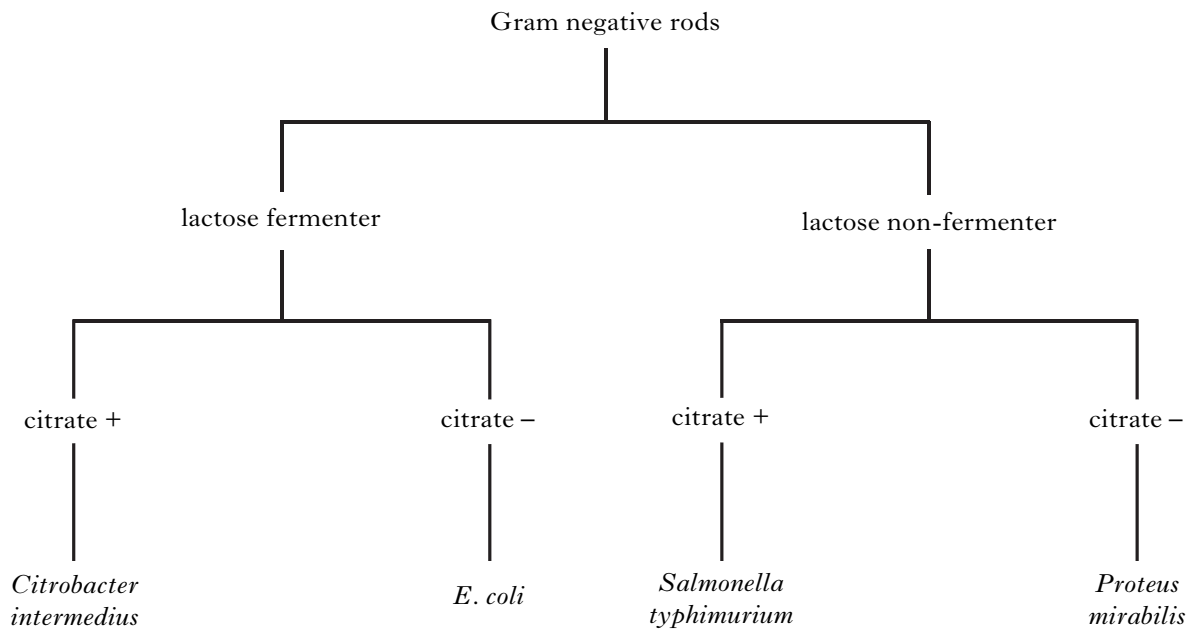

Which of the following statements is true for *E. coli*?

- A It ferments lactose and cannot grow on citrate.
- B It ferments lactose and can grow on citrate.
- C It does not ferment lactose and cannot grow on citrate.
- D It does not ferment lactose and can grow on citrate.

18. Biochemical tests were carried out on *E. coli*. The results showed that *E. coli* could break down hydrogen peroxide and that cytochrome c was absent.

What conclusion can be drawn about the enzymes produced by *E. coli*?

- A Catalase and cytochrome oxidase are produced.
- B Cytochrome oxidase is produced but catalase is not produced.
- C Catalase is produced but cytochrome oxidase is not produced.
- D Neither catalase nor cytochrome oxidase is produced.

19. A culture contained  $5 \times 10^8$  bacteria per  $\text{cm}^3$ . When  $0.1 \text{ cm}^3$  of a serial dilution of the culture was plated and incubated, 50 colonies grew. By how many times had the original culture been diluted before plating?

- A  $10^5$
- B  $10^6$
- C  $10^7$
- D  $10^8$

20. The diagram below shows an aerobic fermenter.

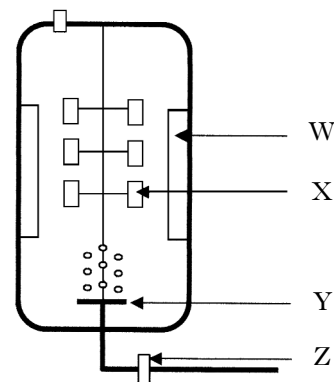

Which line in the table below identifies correctly the components of the fermenter?

	W	X	Y	Z
A	Paddles	Baffles	Sparger	Air filter
B	Baffles	Paddles	Sparger	Air filter
C	Baffles	Paddles	Air filter	Sparger
D	Paddles	Baffles	Air filter	Sparger

21. The stages involved in the process of isolating an intracellular product from bacteria are shown below. Identify the stage at which **both** enzymes and detergents would be used.

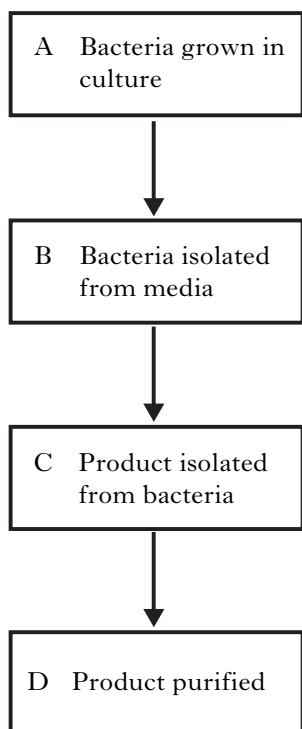

22. Protoplasts are formed from plant cells by removal of the
- A nucleus
  - B cell wall
  - C cytoplasm
  - D cell membrane.
23. Embryo manipulation is a technique used to
- A determine the sex of an embryo
  - B introduce new features
  - C increase the rate of reproduction
  - D produce transgenic animals.

24. Which of the following methods is used to extract citric acid from liquid medium?
- A Solvent extraction
  - B Flocculation
  - C Distillation
  - D Addition of lime
25. Which term is used to describe the production of a large number of identical plants?
- A Cloning vectors
  - B Transformation
  - C Microinjection
  - D Micropropagation

**[Turn over**

26. The graph below shows the area of genetically modified crops grown in industrial and developing countries between 1995 and 2001.

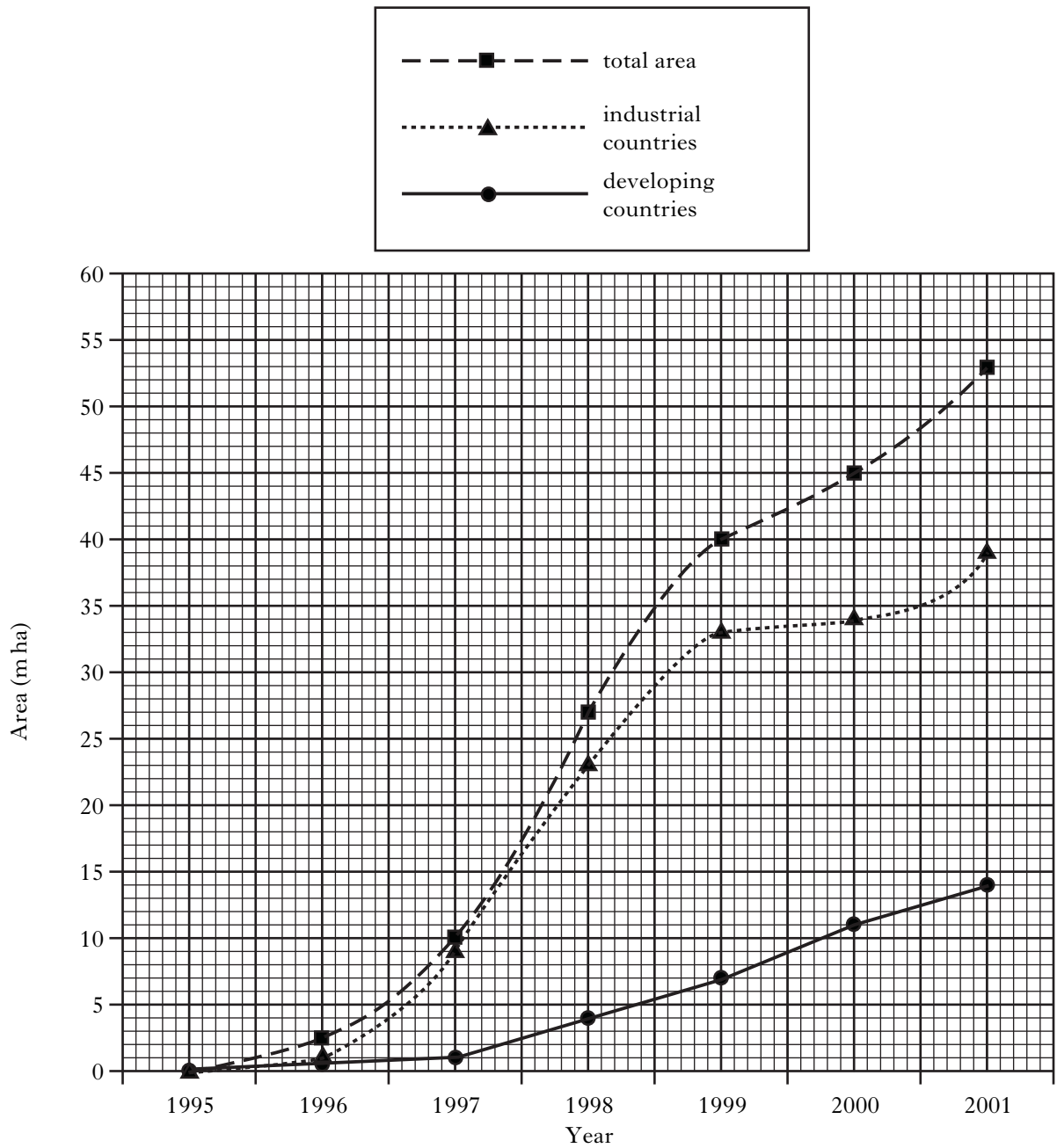

In industrial countries, what was the greatest increase in the area of genetically modified crops in a single year?

- A 3 m ha
- B 10 m ha
- C 14 m ha
- D 17 m ha

27. Which of the following medical products is **not** produced in transgenic animals?

- A Interferon
- B Alpha-1-antitrypsin
- C Penicillin
- D Blood clotting factor

28. Which of the following techniques is used in stem cell culture?

- A Embryo cloning
- B Somatic cell cloning
- C Embryo manipulation
- D Hybrid cell production

29. The diagram below shows the result of a DNA profile of samples collected from two crime scenes and four suspects.

Which suspect was present at both crime scenes?

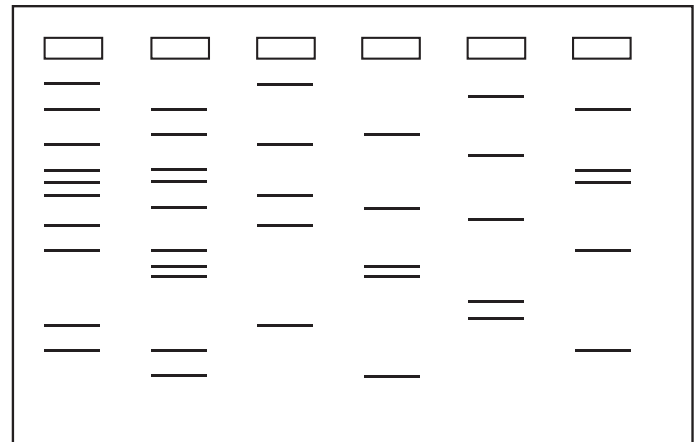

Crime scene 1    Crime scene 2    Suspect A    Suspect B    Suspect C    Suspect D

30. Which line in the table below identifies correctly the components of a biosensor?

	<i>Signal</i>	<i>Transducer</i>
A	Antibody	Dye
B	Dye	Antibody
C	Luminescence	Dye
D	Antibody	Enzyme

**Candidates are reminded that the answer sheet for Section A MUST be returned INSIDE the front cover of this answer book.**

**[Turn over for Section B on Page ten**

Marks

SECTION B

All questions in this Section should be attempted.  
All answers must be written clearly and legibly in ink.

1. (a) The diagram below shows a yeast cell reproducing. This process requires energy.

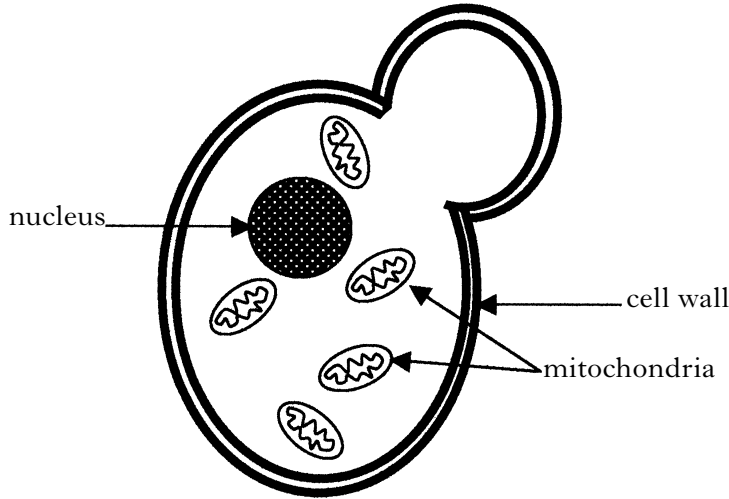

- (i) What form of reproduction is occurring in this yeast cell?

\_\_\_\_\_ 1

- (ii) The mitochondria are the site of aerobic respiration. Complete the equation for this reaction by filling in the boxes below.

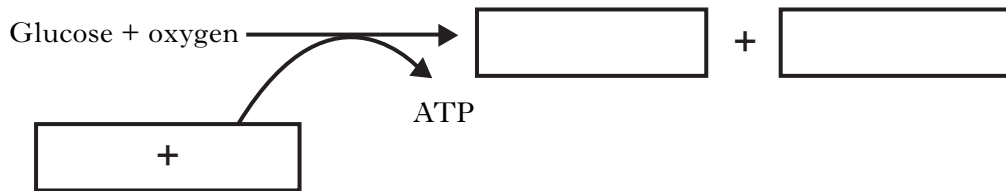

2

- (iii) Underline one of the alternatives in each pair to make the sentence correct.

Yeast cells can also respire in the absence of oxygen. They can therefore be described as  $\left\{ \begin{array}{l} \text{facultative} \\ \text{obligate} \end{array} \right\} \left\{ \begin{array}{l} \text{aerobes} \\ \text{anaerobes} \end{array} \right\}$ .

1

- (iv) In the absence of oxygen, what is the net gain of ATP molecules from the metabolism of one glucose molecule?

\_\_\_\_\_ 1

Marks

1. (continued)

(b) The number of yeast cells in a solution can be estimated using a haemocytometer. The diagram below shows one square from a haemocytometer containing a yeast suspension.

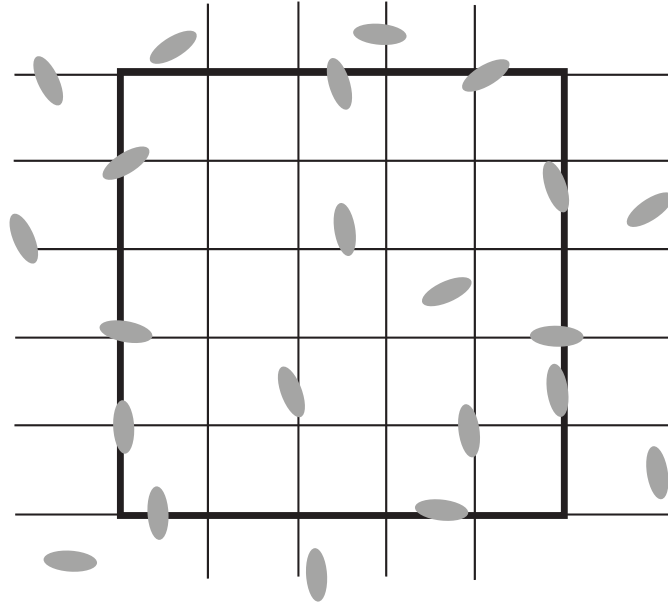

(i) How many yeast cells should be counted in the big square?

\_\_\_\_\_ yeast cells

1

(ii) The instructions for **this haemocytometer** state that the number of cells counted should be multiplied by  $10^4$  to give the number of cells per  $\text{cm}^3$ .

If the yeast suspension used in this experiment had been diluted 1 in 10 before being added to the haemocytometer, how many cells per  $\text{cm}^3$  were in the undiluted yeast suspension?

*Space for calculation*

\_\_\_\_\_

1

[Turn over

2. Diagram 1 shows the insertion of foreign DNA into a plasmid, which was then used *Marks* to transform bacterial cells.

**Diagram 1**

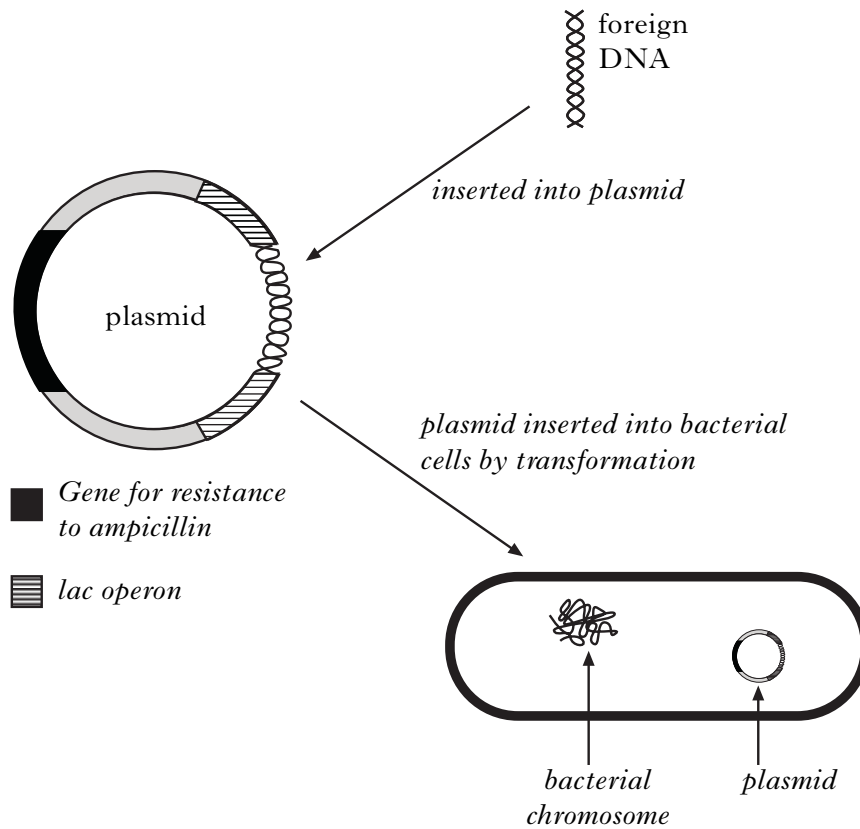

- (a) Name the enzyme used to insert the foreign DNA into the plasmid.

\_\_\_\_\_ 1

- (b) What is the function of the *lac* operon **in the plasmid shown above**?

\_\_\_\_\_  
\_\_\_\_\_ 1

- (c) Explain why the plasmid must be introduced into a bacterial cell.

\_\_\_\_\_ 1

- (d) State **one** advantage of using bacterial cells, such as *E. coli*, as the recipient for foreign DNA.

\_\_\_\_\_ 1

Marks

2. (continued)

- (e) Following the transformation procedure, samples of bacterial cells were plated on two different types of medium and incubated overnight at 30 °C.

The results are shown in diagram 2.

**Diagram 2**

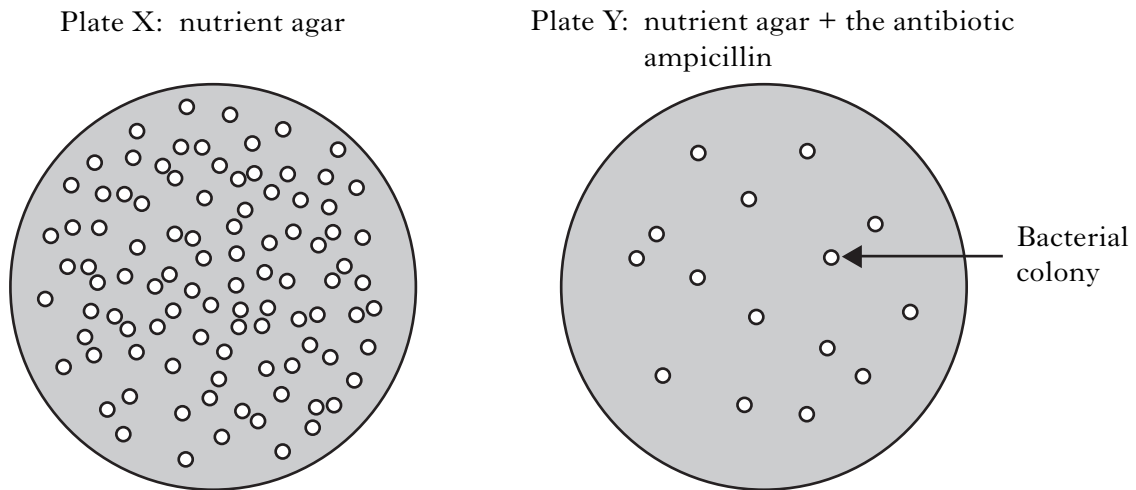

- (i) Explain the difference in the number of colonies on plates X and Y.

---

---

---

2

- (ii) Describe how one of the bacterial colonies could be cloned.

---

1

[Turn over

Marks

3. (a) Rubella is a virus that causes fever and a rash, and may cause birth defects.  
A vaccine against the Rubella virus is available.

The graph shows the concentration of antibodies against Rubella in the blood of two patients who were exposed to this virus.

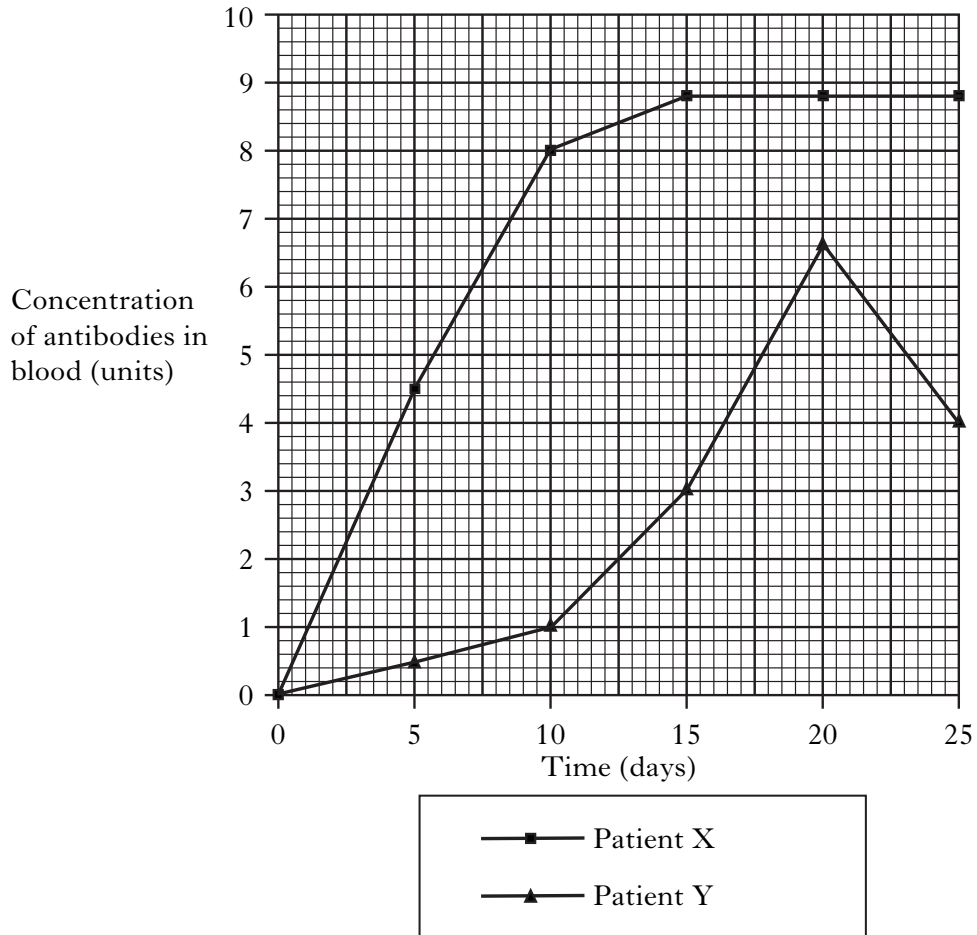

- (i) Explain the difference in antibody concentration between patient X and patient Y.

---



---



---

2

- (ii) Calculate the simple whole number ratio of antibody concentration at day 20 in the blood of patient X and patient Y.

*Space for calculation*

Patient X \_\_\_\_\_ : \_\_\_\_\_ Patient Y 1

Marks

3. (a) (continued)

(iii) By how many times does the antibody concentration in the blood of patient Y increase between days 5 and 15?

*Space for calculation*

1

(b) Match each description with the type of immunity by ticking (✓) the **two** correct boxes in **each** line of the table.

<i>Description</i>	<i>Type of Immunity</i>			
	<i>Naturally acquired</i>	<i>Artificially acquired</i>	<i>Passive</i>	<i>Active</i>
Receiving anti-rabies antibodies				
Baby receiving immunity from mother				
Recovery from viral infection				
Vaccination against polio				

3

[Turn over

Marks

4. A microbiologist prepared flasks of sterile liquid medium and sterile glass pipettes for an experiment.

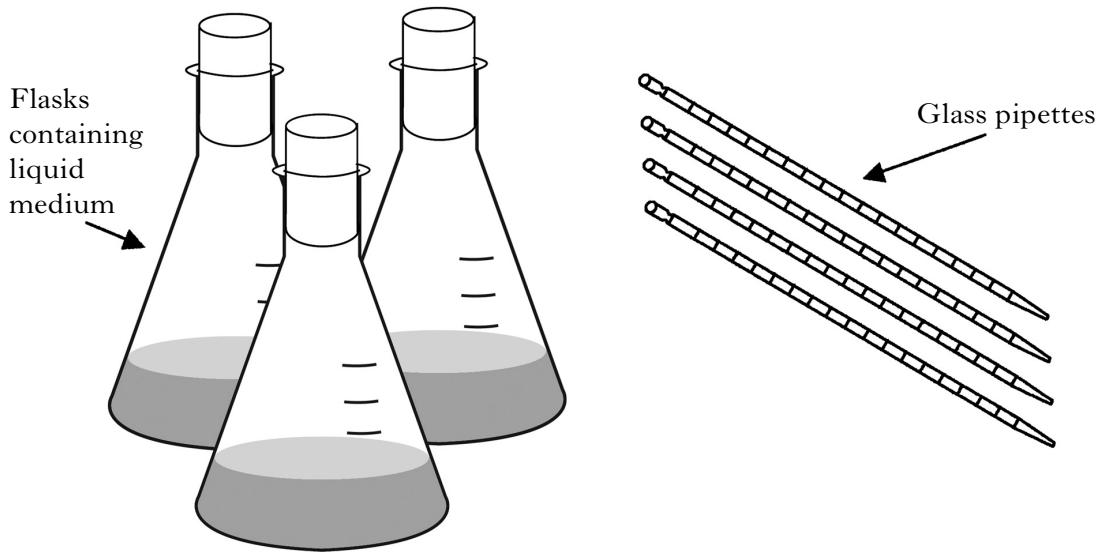

- (a) (i) Complete the table to show the method, temperature and time of sterilisation for these items.

	<i>Method of sterilisation</i>	<i>Temperature (°C)</i>	<i>Time of sterilisation</i>
Flasks containing medium			
Glass pipettes			

2

- (ii) What would the microbiologist use to check that sterilisation was successful?

\_\_\_\_\_

1

Marks

4. (continued)

(b) The experiment also required a solution of glucose which was prepared from a stock solution.

(i) The solution of glucose would be damaged by heat sterilisation. Suggest how this solution could be sterilised.

\_\_\_\_\_ 1

(ii) If the concentration of the glucose stock solution was 0.5 M, what volumes of stock solution and water would be required to prepare 100 cm<sup>3</sup> of 0.1 M glucose?

*Space for calculation*

\_\_\_\_\_ cm<sup>3</sup> stock solution \_\_\_\_\_ cm<sup>3</sup> water 1

(c) Before starting the experiment the microbiologist carried out a risk assessment on the procedures to be used. Hazards were identified and the associated risk assessed.

(i) Describe what is meant by the term “risk”.

\_\_\_\_\_ 1

(ii) One of the procedures was covered by a **generic** risk assessment. Describe what is meant by this term.

\_\_\_\_\_  
\_\_\_\_\_ 1

(iii) Apart from personal protective equipment, describe **two** other control measures to reduce risk when carrying out experiments with bacteria.

1 \_\_\_\_\_  
2 \_\_\_\_\_ 2

[Turn over

Marks

5. An experiment was set up to investigate the optimum growth temperature of a species of bacteria. The results are shown in the graph below.

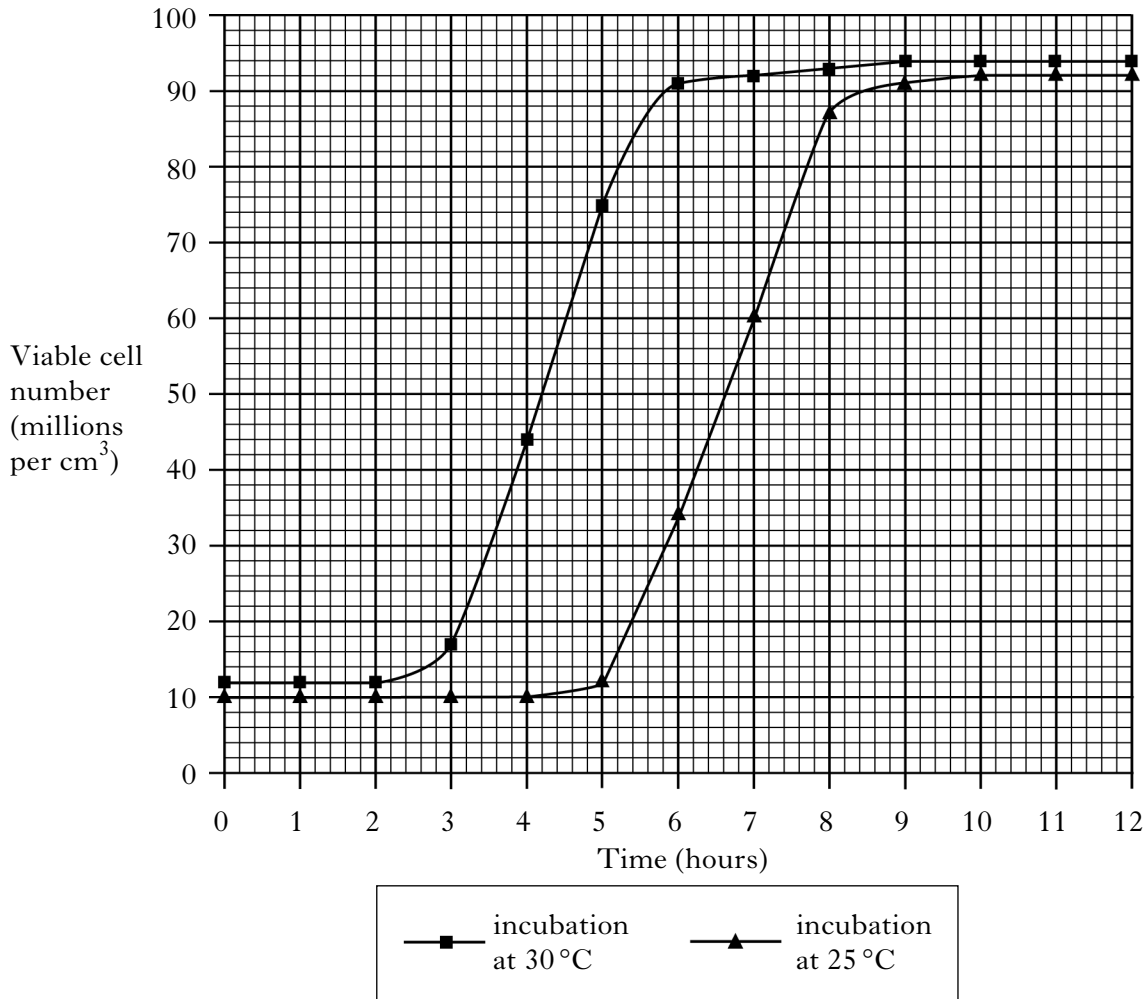

- (a) (i) How long does lag phase last when the bacteria are grown at 25 °C?

\_\_\_\_\_ hours

1

- (ii) Name the **two** other phases of growth that can be seen in the graph.

1 \_\_\_\_\_

2 \_\_\_\_\_

1

- (iii) How much longer does it take the culture to reach 60 million viable cells per cm<sup>3</sup> at 25 °C than at 30 °C?

*Space for calculation*

\_\_\_\_\_ hours

1

Marks

**5. (continued)**

(b) Explain what is happening to the cells in the cultures after 9 hours.

---

---

2

(c) Suggest a reason why the cells grow more rapidly at 30°C than at 25°C.

---

---

1

**[Turn over**

Marks

6. The graph shows the number of reported cases of hospital acquired infection (HAI) in a hospital over a period of 7 years.

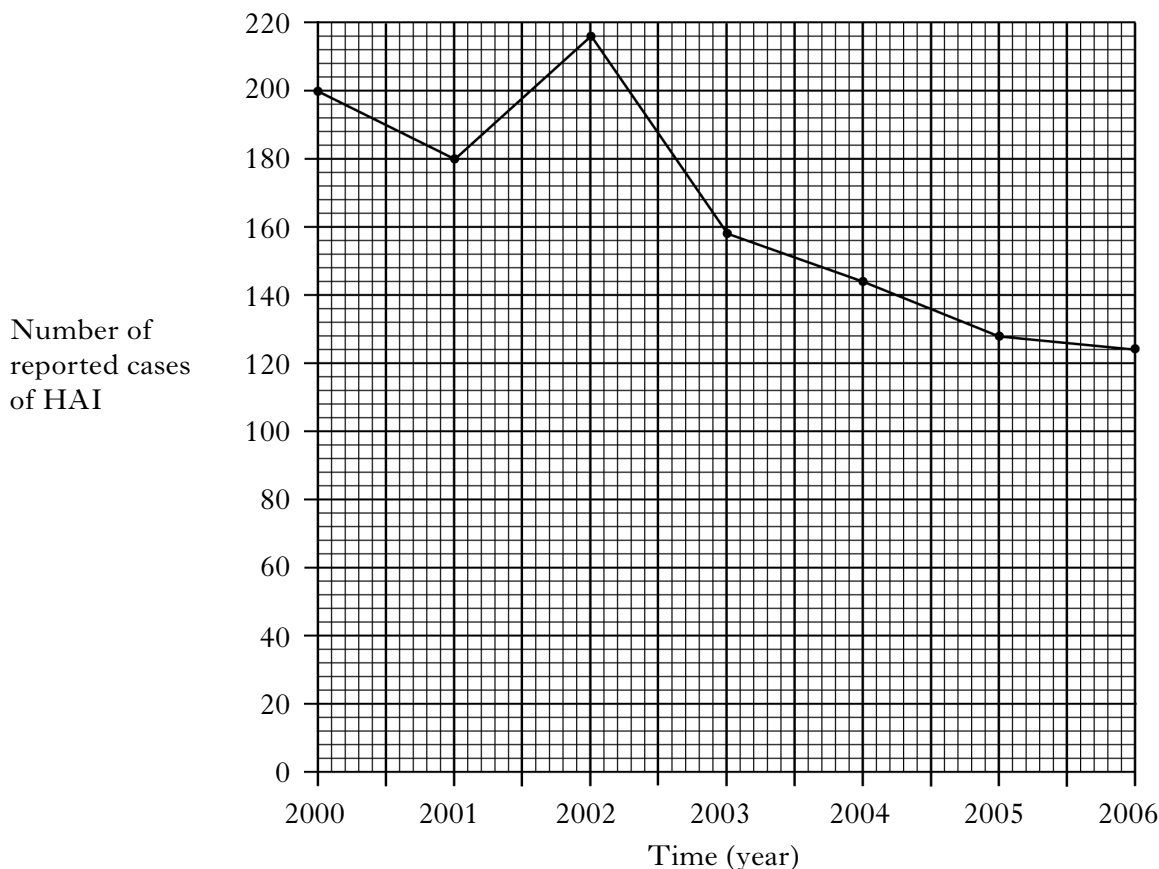

- (a) Between which two years did the greatest decrease in total number of cases of HAI occur?

\_\_\_\_\_

1

- (b) Using the graph, calculate the percentage increase in reported cases of HAI between 2001 and 2002.

*Space for calculation*

\_\_\_\_\_

1

- (c) In 2003 a new handwashing procedure was introduced at the hospital. Predict the effect this procedure will have on the overall trend in cases of HAI after 2006 and give a reason for your answer.

Prediction \_\_\_\_\_

\_\_\_\_\_

Reason \_\_\_\_\_

\_\_\_\_\_

1

Marks

6. (continued)

The table below shows the percentage of cases of HAI in the hospital caused by two species of bacteria over the same 7 year period.

	<i>Percentage of cases of HAI in each year (%)</i>						
	<i>2000</i>	<i>2001</i>	<i>2002</i>	<i>2003</i>	<i>2004</i>	<i>2005</i>	<i>2006</i>
<i>Clostridium</i>	31	30	32	30	54	57	59
<i>Staphylococcus</i>	34	31	33	32	31	33	33

- (d) Using the graph and the table, calculate the number of cases of HAI caused by *Clostridium* species in 2001.

*Space for calculation*

\_\_\_\_\_

1

- (e) Compare the overall trend in the percentage of *Clostridium* cases over the 7 year period with that of *Staphylococcus* cases.

\_\_\_\_\_  
\_\_\_\_\_  
\_\_\_\_\_

1

- (f) Using the graph and table, what conclusion can be drawn about the effectiveness of the new handwashing procedure on the number of cases of *Staphylococcus* species?

\_\_\_\_\_  
\_\_\_\_\_

1

- (g) Some cases of HAI are caused by spore forming bacteria. Explain why it is more difficult to reduce the number of cases of infection caused by these bacteria.

\_\_\_\_\_  
\_\_\_\_\_

1

[Turn over

7. Two species of bacteria were isolated from an environmental sample and stored as slope cultures until identification tests could be carried out. *Marks*

(a) Describe how an agar slope should be prepared.

---

---

2

(b) The identification process included plating the bacteria on differential medium.

(i) What factors must be considered when selecting a plate suitable for inoculation?

---

1

(ii) Describe how differential medium distinguishes between bacterial species.

---

1

(c) The bacteria were also grown on a medium that contained only defined nutritional ingredients in precise concentrations.

(i) What name is given to this type of medium?

---

1

(ii) What is added to the medium to prevent the pH changing during growth of the bacteria?

---

1

8. (a) The diagram below shows the stages involved in the production of monoclonal antibodies. Marks

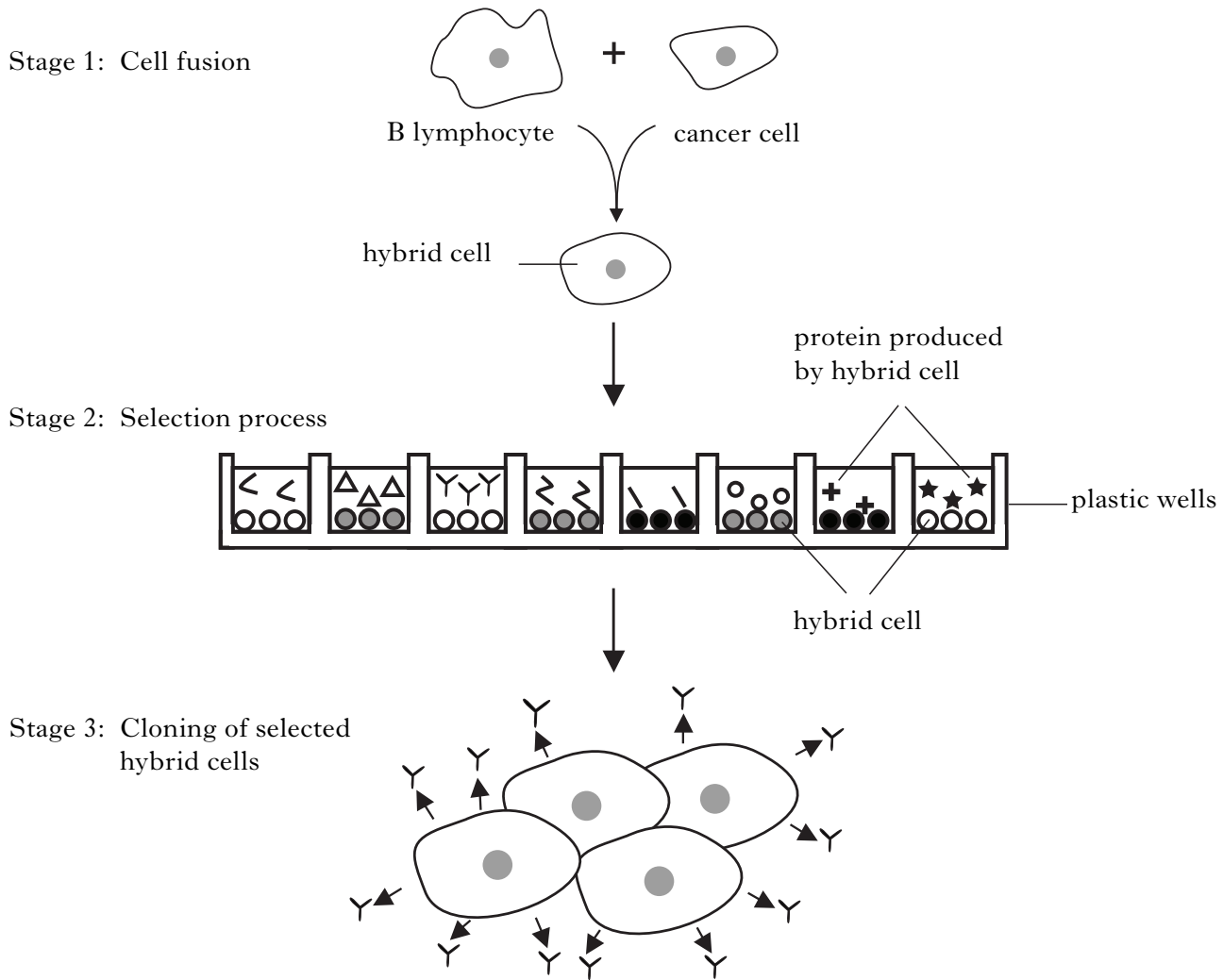

(i) Explain why B lymphocytes are used in Stage 1 of this process.

---



---

1

(ii) What is the purpose of the selection process at Stage 2?

---



---

1

(b) Suggest how treatment with an anti-cancer drug attached to a monoclonal antibody may be more effective than treatment with an unattached drug.

---



---

2

9. The growth requirements of animal cells were investigated by growing the cells in two bioreactors. *Marks*

**Bioreactor M** contained growth medium.

**Bioreactor N** contained growth medium **plus** serum.

Samples were taken from the bioreactors each day for six days and cell counts were carried out. The results are shown in the table below.

<i>Days in Culture</i>	<i>Bioreactor M</i> <i>Average number of cells per</i> <i>cm<sup>3</sup> (<math>\times 10^5</math>)</i>	<i>Bioreactor N</i> <i>Average number of cells per</i> <i>cm<sup>3</sup> (<math>\times 10^5</math>)</i>
0	4.0	4.0
1	5.0	5.0
2	5.0	9.5
3	3.5	10.0
4	2.5	14.5
5	1.5	26.5
6	0.5	30.0

- (a) Plot line graphs of the average number of cells against days in culture for bioreactors **M and N**.

(Additional graph paper, if required, can be found on page 35.)

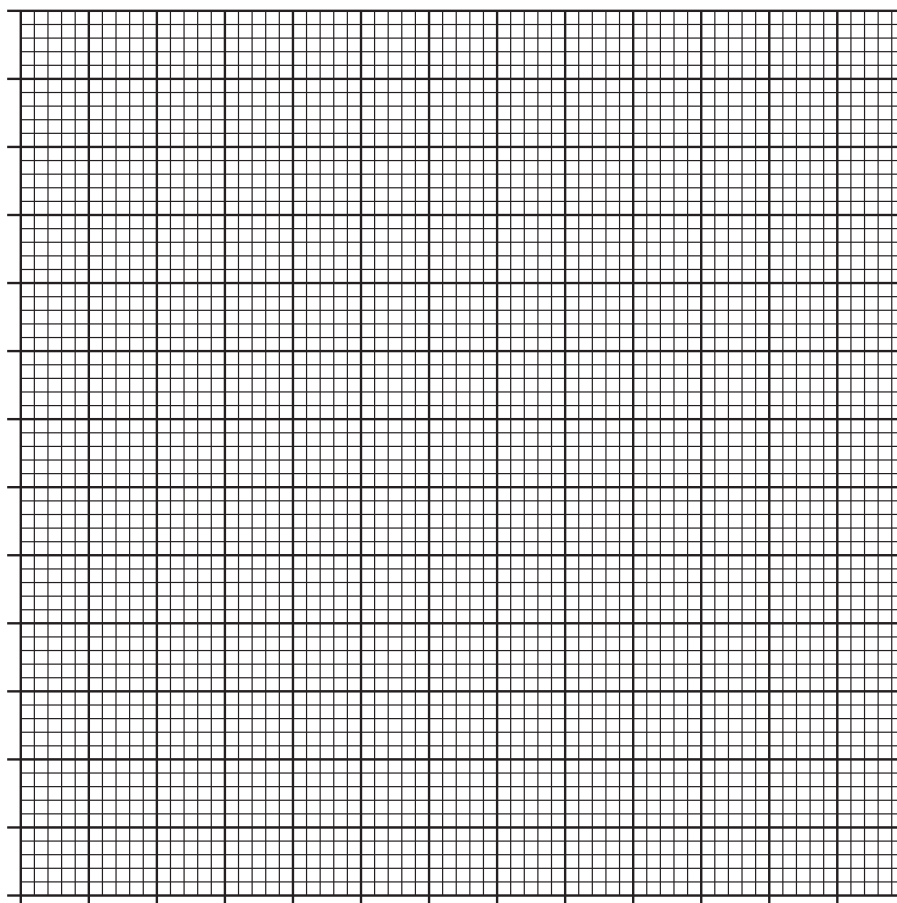

9. (continued)

Marks

- (b) (i) State the conclusion that can be drawn from this data.

\_\_\_\_\_

\_\_\_\_\_

1

- (ii) Between which two days did the number of cells in Bioreactor N show the greatest increase?

\_\_\_\_\_

1

- (c) Describe **two** precautions to prevent contamination that must be taken when setting up the bioreactors.

1 \_\_\_\_\_

2 \_\_\_\_\_

2

- (d) Explain why serum was not added to Bioreactor M.

\_\_\_\_\_

1

The cells in this experiment were grown in batch culture.

- (e) (i) Describe what is meant by batch culture.

\_\_\_\_\_

1

- (ii) State **one** advantage of growing cells in batch culture.

\_\_\_\_\_

1

[Turn over

Marks

10. The Hepatitis B virus has a surface protein called HBsAg. HBsAg is used to vaccinate humans against Hepatitis B.

Yeast cells were genetically modified to synthesise and secrete HBsAg.

Some of the steps involved in production of HBsAg using these modified yeast cells are shown below.

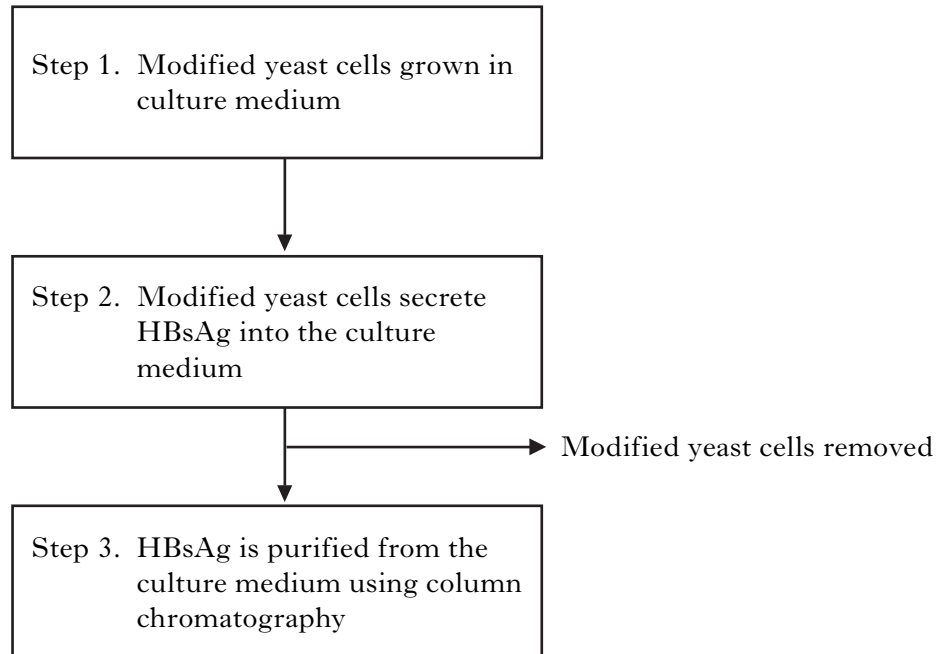

(a) (i) Describe how the modified yeast cells could be removed from the culture medium.

\_\_\_\_\_

1

(ii) Step 3 involves protein purification by column chromatography. Name **two** properties of the protein that could be used to purify it by this method.

\_\_\_\_\_

\_\_\_\_\_

1

*Marks*

**10. (continued)**

- (b) HBsAg was originally purified from the plasma of individuals infected with Hepatitis B virus and used as a vaccine.

Explain why the vaccine produced using HBsAg from genetically modified yeast is more suitable.

---

---

**1**

- (c) Give a reason why yeast cells are used to produce HBsAg instead of bacterial cells.

---

**1**

- (d) Give **two** factors that should be considered when scaling up a process from a laboratory model to an industrial fermenter.

1 

---

2 

---

**2**

**[Turn over**

Marks

11. Embryo cloning has been developed for many mammals including mice. An outline of this process is shown below.

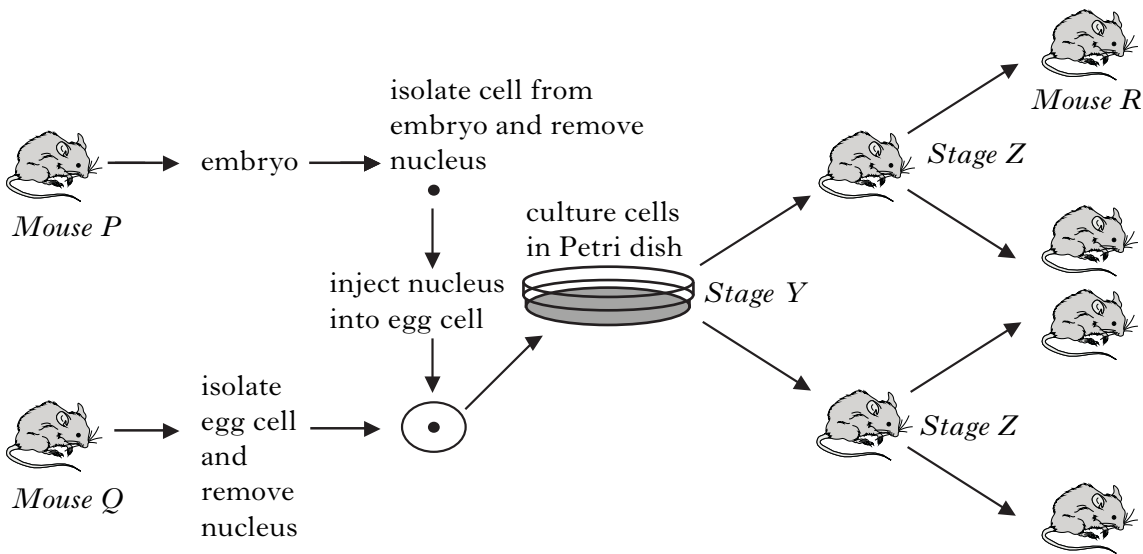

(a) Cells are cultured to a stage of development in the Petri dish. Name this stage of cell development.

\_\_\_\_\_

1

(b) Describe what is happening at Stage Y.

\_\_\_\_\_

\_\_\_\_\_

1

(c) Describe the relationship between the embryo taken from mouse P and mouse R.

\_\_\_\_\_

\_\_\_\_\_

1

(d) Describe **one** similarity and **one** difference between embryo cloning and somatic cell cloning.

Similarity \_\_\_\_\_

\_\_\_\_\_

Difference \_\_\_\_\_

\_\_\_\_\_

2

(e) What is the purpose of embryo cloning and somatic cell cloning?

\_\_\_\_\_

1

Marks

12. Following a spillage of crude oil, an area of land was treated with a micro-organism that degraded the pollutant Total Petroleum Hydrocarbon (TPH). The bar chart shows the breakdown of TPH by the micro-organism over 21 days from the day that treatment started (day 0).

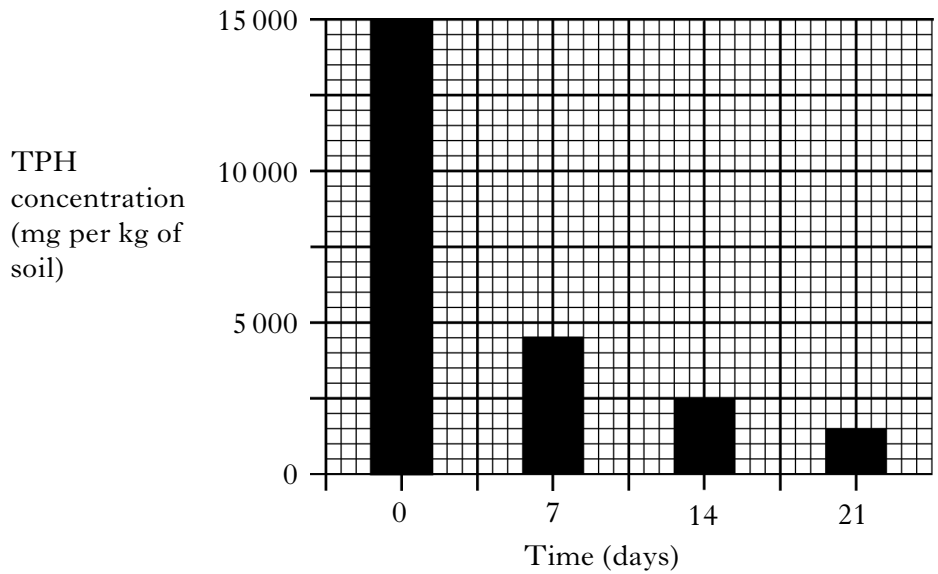

- (a) What name is given to the process by which micro-organisms are used to degrade spillages of harmful chemicals such as crude oil?

\_\_\_\_\_

1

- (b) Use the data in the bar chart to calculate the percentage decrease in TPH concentration between day 0 and day 21.

*Space for calculation*

\_\_\_\_\_

1

- (c) Calculate the average mass of TPH degraded per day between day 0 and day 7.

*Space for calculation*

\_\_\_\_\_ mg per kg of soil

1

- (d) Describe a laboratory procedure that could be used to identify micro-organisms that break down pollutants such as TPH.

\_\_\_\_\_  
\_\_\_\_\_

2

[Turn over for Section C on Page thirty

## SECTION C

Marks

**Both questions in this section should be attempted.**

**Note that each question contains a choice.**

**Questions 1 and 2 should be attempted on the blank pages which follow.**

**All answers must be written clearly and legibly in ink.**

**Supplementary sheets, if required, may be obtained from the invigilator.**

**Labelled diagrams may be used where appropriate.**

**1. Answer either A or B.**

**A.** Discuss the applications of biotechnology in agriculture under the following headings:

- (a) production of transgenic plants and animals; 4  
(b) crop protection. 6

**(10)**

**OR**

**B.** Give an account of the application of immobilised enzymes in biotechnology under the following headings:

- (a) methods for immobilising enzymes; 3  
(b) advantages of immobilising enzymes; 2  
(c) therapeutic and industrial applications of immobilised enzymes. 5

**(10)**

**In Question 2 ONE mark is available for coherence and ONE mark is available for relevance.**

**2. Answer either A or B.**

**A.** Prokaryotes and eukaryotes both carry out transcription (synthesis of mRNA) and translation (synthesis of protein). Describe the similarities and differences between prokaryotes and eukaryotes in the way they carry out these processes. (10)

**OR**

**B.** Give an account of the purification and fragmentation of DNA, and the separation of the fragments produced. (10)

[END OF QUESTION PAPER]

**SPACE FOR ANSWERS**

**SPACE FOR ANSWERS**

**SPACE FOR ANSWERS**

**SPACE FOR ANSWERS**

**SPACE FOR ANSWERS**

ADDITIONAL GRAPH PAPER FOR USE IN QUESTION 9 (a)

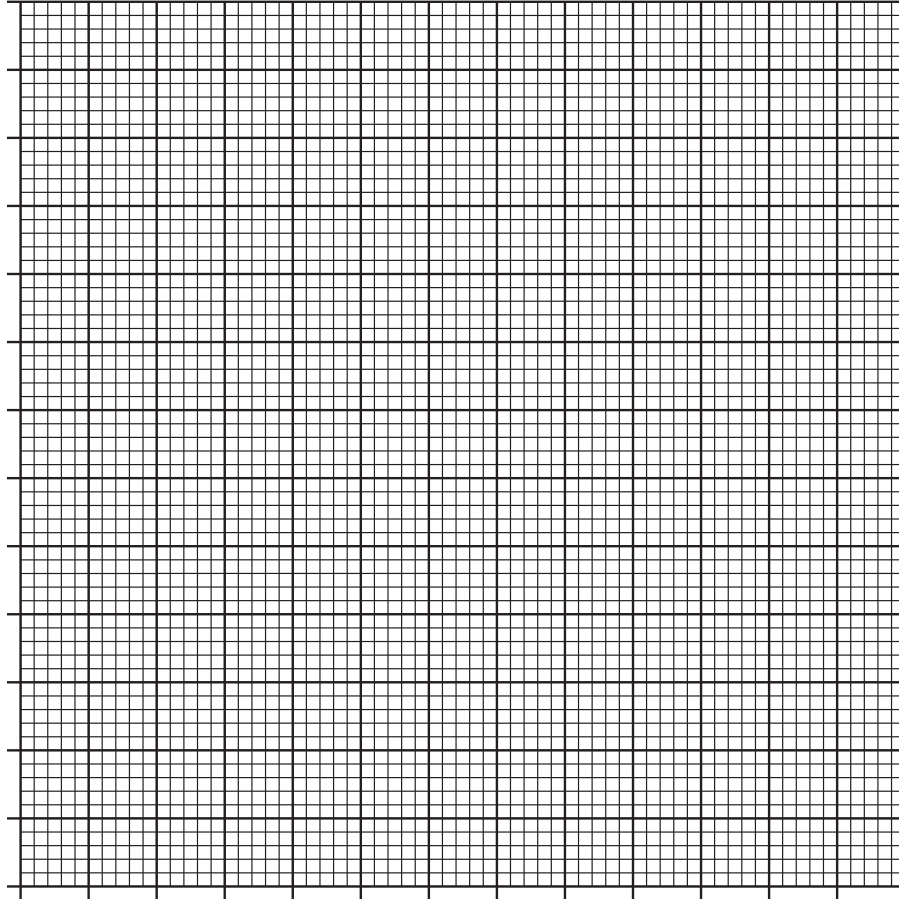

**[BLANK PAGE]**