

# X069/301

NATIONAL  
QUALIFICATIONS  
2009

TUESDAY, 26 MAY  
1.00 PM – 3.30 PM

PHYSICS  
HIGHER

## Read Carefully

Reference may be made to the Physics Data Booklet.

- 1 All questions should be attempted.

## Section A (questions 1 to 20)

- 2 Check that the answer sheet is for Physics Higher (Section A).
- 3 For this section of the examination you must use an **HB pencil** and, where necessary, an eraser.
- 4 Check that the answer sheet you have been given has **your name, date of birth, SCN** (Scottish Candidate Number) and **Centre Name** printed on it.  
Do not change any of these details.
- 5 If any of this information is wrong, tell the Invigilator immediately.
- 6 If this information is correct, **print** your name and seat number in the boxes provided.
- 7 There is **only one correct** answer to each question.
- 8 Any rough working should be done on the question paper or the rough working sheet, **not** on your answer sheet.
- 9 At the end of the exam, put the **answer sheet for Section A inside the front cover of your answer book**.
- 10 Instructions as to how to record your answers to questions 1–20 are given on page three.

## Section B (questions 21 to 30)

- 11 Answer the questions numbered 21 to 30 in the answer book provided.
- 12 **All answers must be written clearly and legibly in ink.**
- 13 Fill in the details on the front of the answer book.
- 14 Enter the question number clearly in the margin of the answer book beside each of your answers to questions 21 to 30.
- 15 Care should be taken to give an appropriate number of significant figures in the final answers to calculations.
- 16 Where additional paper, eg square ruled paper, is used, write your name and SCN (Scottish Candidate Number) on it and place it inside the front cover of your answer booklet.



## DATA SHEET

### COMMON PHYSICAL QUANTITIES

<i>Quantity</i>	<i>Symbol</i>	<i>Value</i>	<i>Quantity</i>	<i>Symbol</i>	<i>Value</i>
Speed of light in vacuum	$c$	$3.00 \times 10^8 \text{ m s}^{-1}$	Mass of electron	$m_e$	$9.11 \times 10^{-31} \text{ kg}$
Magnitude of the charge on an electron	$e$	$1.60 \times 10^{-19} \text{ C}$	Mass of neutron	$m_n$	$1.675 \times 10^{-27} \text{ kg}$
Gravitational acceleration on Earth	$g$	$9.8 \text{ m s}^{-2}$	Mass of proton	$m_p$	$1.673 \times 10^{-27} \text{ kg}$
Planck's constant	$h$	$6.63 \times 10^{-34} \text{ J s}$			

### REFRACTIVE INDICES

The refractive indices refer to sodium light of wavelength 589 nm and to substances at a temperature of 273 K.

<i>Substance</i>	<i>Refractive index</i>	<i>Substance</i>	<i>Refractive index</i>
Diamond	2.42	Water	1.33
Crown glass	1.50	Air	1.00

### SPECTRAL LINES

<i>Element</i>	<i>Wavelength/nm</i>	<i>Colour</i>	<i>Element</i>	<i>Wavelength/nm</i>	<i>Colour</i>
Hydrogen	656	Red	Cadmium	644	Red
	486	Blue-green		509	Green
	434	Blue-violet		480	Blue
	410	Violet	<i>Lasers</i>		
	397	Ultraviolet	<i>Element</i>	<i>Wavelength/nm</i>	<i>Colour</i>
	389	Ultraviolet	Carbon dioxide	9550 } 10590 }	Infrared
Sodium	589	Yellow	Helium-neon	633	Red

### PROPERTIES OF SELECTED MATERIALS

<i>Substance</i>	<i>Density/ kg m<sup>-3</sup></i>	<i>Melting Point/ K</i>	<i>Boiling Point/ K</i>
Aluminium	$2.70 \times 10^3$	933	2623
Copper	$8.96 \times 10^3$	1357	2853
Ice	$9.20 \times 10^2$	273	...
Sea Water	$1.02 \times 10^3$	264	377
Water	$1.00 \times 10^3$	273	373
Air	1.29	...	...
Hydrogen	$9.0 \times 10^{-2}$	14	20

The gas densities refer to a temperature of 273 K and a pressure of  $1.01 \times 10^5 \text{ Pa}$ .

## SECTION A

For questions 1 to 20 in this section of the paper the answer to each question is either A, B, C, D or E. Decide what your answer is, then, using your pencil, put a horizontal line in the space provided—see the example below.

### EXAMPLE

The energy unit measured by the electricity meter in your home is the

- A kilowatt-hour
- B ampere
- C watt
- D coulomb
- E volt.

The correct answer is **A**—kilowatt-hour. The answer **A** has been clearly marked in **pencil** with a horizontal line (see below).

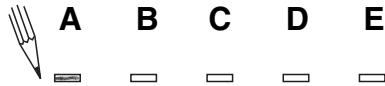

### Changing an answer

If you decide to change your answer, carefully erase your first answer and, using your pencil, fill in the answer you want. The answer below has been changed to **E**.

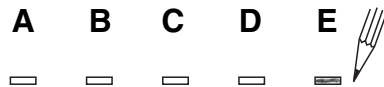

[Turn over

SECTION A

Answer questions 1–20 on the answer sheet.

1. Which of the following contains one vector and one scalar quantity?

- A power; speed
- B force; kinetic energy
- C momentum; velocity
- D work; potential energy
- E displacement; acceleration

2. The following velocity-time graph represents the vertical motion of a ball.

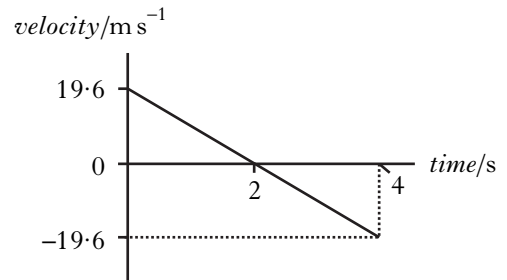

Which of the following acceleration-time graphs represents the same motion?

A

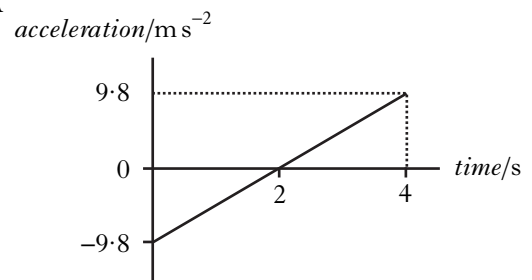

B

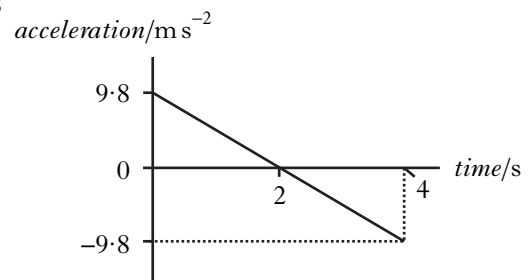

C

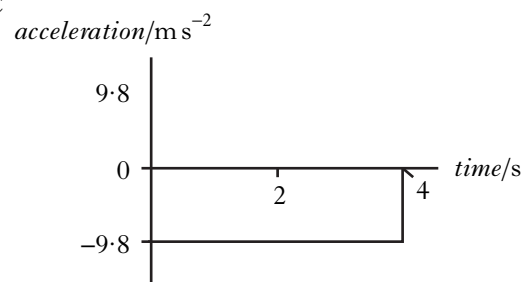

D

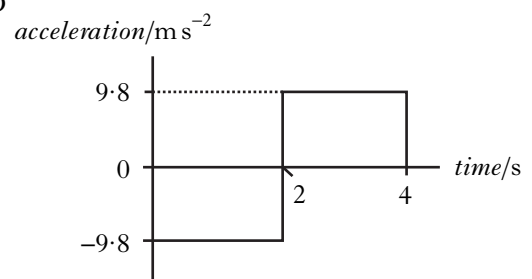

E

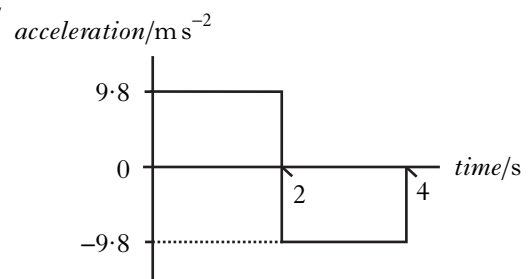

3. A box of weight 120 N is placed on a smooth horizontal surface.  
A force of 20 N is applied to the box as shown.

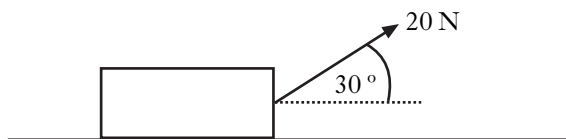

The box is pulled a distance of 50 m along the surface.

The work done in pulling the box is

- A 500 J  
B 866 J  
C 1000 J  
D 6000 J  
E 6866 J.
4. A skydiver of total mass 85 kg is falling vertically.



At one point during the fall, the air resistance on the skydiver is 135 N.

The acceleration of the skydiver at this point is

- A  $0.6 \text{ m s}^{-2}$   
B  $1.6 \text{ m s}^{-2}$   
C  $6.2 \text{ m s}^{-2}$   
D  $8.2 \text{ m s}^{-2}$   
E  $13.8 \text{ m s}^{-2}$ .

5. A 2.0 kg trolley travels in a straight line towards a stationary 5.0 kg trolley as shown.



The trolleys collide. After the collision the trolleys move as shown below.



What is the speed  $v$  of the 5.0 kg trolley after the collision?

- A  $0.4 \text{ m s}^{-1}$   
B  $1.2 \text{ m s}^{-1}$   
C  $2.0 \text{ m s}^{-1}$   
D  $2.2 \text{ m s}^{-1}$   
E  $3.0 \text{ m s}^{-1}$
6. The density of the gas in a container is initially  $5.0 \text{ kg m}^{-3}$ .
- Which of the following increases the density of the gas?
- I Raising the temperature of the gas without changing its mass or volume.  
II Increasing the mass of the gas without changing its volume or temperature.  
III Increasing the volume of the gas without changing its mass or temperature.
- A II only  
B III only  
C I and II only  
D II and III only  
E I, II and III

**[Turn over**

7. For a fixed mass of gas at constant volume
- A the pressure is directly proportional to temperature in  $^{\circ}\text{C}$
  - B the pressure is inversely proportional to temperature in  $^{\circ}\text{C}$
  - C the pressure is directly proportional to temperature in K
  - D the pressure is inversely proportional to temperature in K
  - E (pressure  $\times$  temperature in K) is constant.

8. A potential difference,  $V$ , is applied between two metal plates. The plates are  $0.15\text{ m}$  apart. A charge of  $+4.0\text{ mC}$  is released from rest at the positively charged plate as shown.

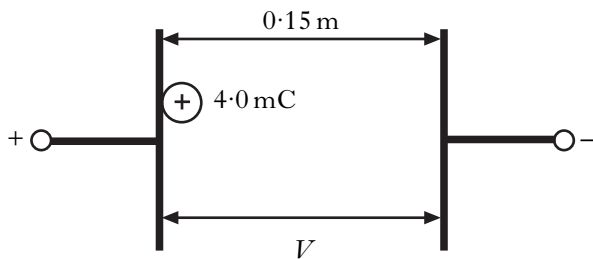

The kinetic energy of the charge just before it hits the negative plate is  $8.0\text{ J}$ .

The potential difference between the plates is

- A  $3.2 \times 10^{-2}\text{ V}$
- B  $1.2\text{ V}$
- C  $2.0\text{ V}$
- D  $2.0 \times 10^3\text{ V}$
- E  $4.0 \times 10^3\text{ V}$ .

9. A battery of e.m.f.  $24\text{ V}$  and negligible internal resistance is connected as shown.

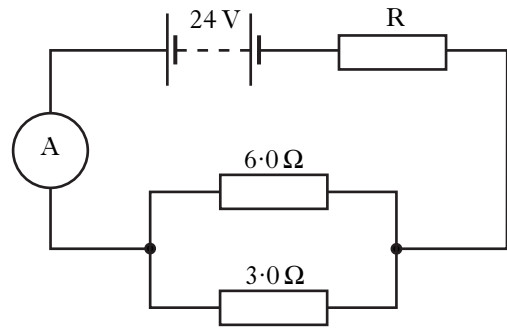

The reading on the ammeter is  $2.0\text{ A}$ .

The resistance of  $R$  is

- A  $3.0\ \Omega$
- B  $4.0\ \Omega$
- C  $10\ \Omega$
- D  $12\ \Omega$
- E  $18\ \Omega$ .

10. The diagram shows a Wheatstone Bridge.

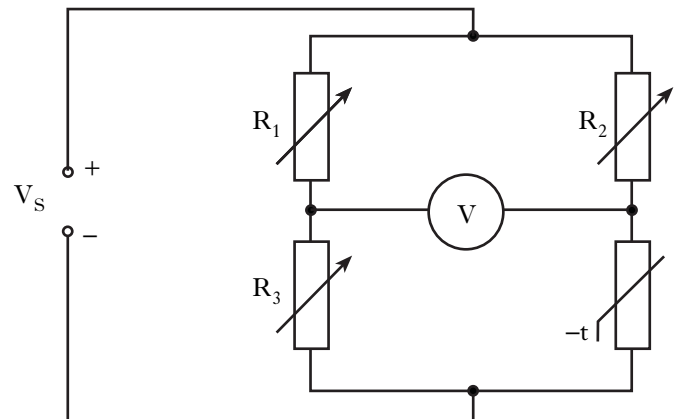

The bridge is initially balanced.

The thermistor is then heated and its resistance decreases. The bridge could be returned to balance by

- A decreasing  $R_1$
- B decreasing  $R_2$
- C increasing  $R_2$
- D increasing  $R_3$
- E increasing  $V_S$ .

11. A  $25.0\ \mu\text{F}$  capacitor is charged until the potential difference across it is  $500\ \text{V}$ .  
The charge stored in the capacitor is
- A  $5.00 \times 10^{-8}\ \text{C}$   
 B  $2.00 \times 10^{-5}\ \text{C}$   
 C  $1.25 \times 10^{-2}\ \text{C}$   
 D  $1.25 \times 10^4\ \text{C}$   
 E  $2.00 \times 10^7\ \text{C}$ .

12. A student connects an a.c. supply to an a.c. ammeter and a component **X**.

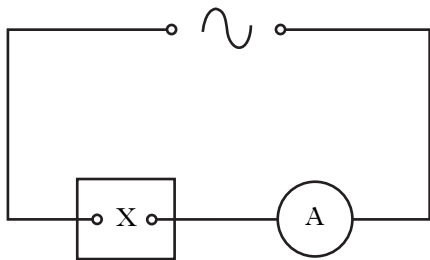

As the frequency of the a.c. supply is steadily increased, the ammeter reading also increases.

Component **X** is a

- A capacitor  
 B diode  
 C lamp  
 D resistor  
 E transistor.

13. An amplifier circuit is set up as shown.

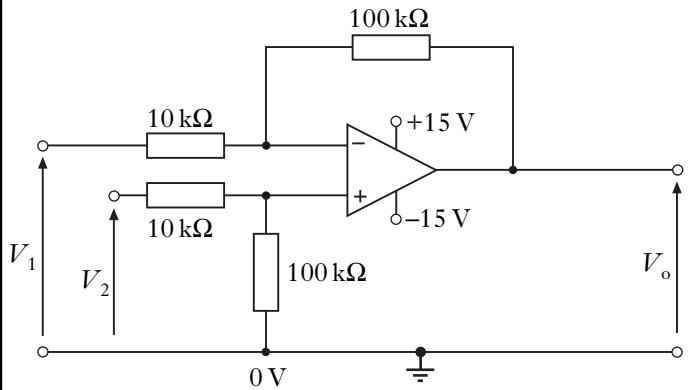

When  $V_o = 0.60\ \text{V}$  and  $V_1 = 2.70\ \text{V}$ , what is the value of  $V_2$ ?

- A  $2.10\ \text{V}$   
 B  $2.64\ \text{V}$   
 C  $2.76\ \text{V}$   
 D  $3.30\ \text{V}$   
 E  $8.70\ \text{V}$

**[Turn over**

14. A prism is used to produce a spectrum from a source of white light as shown.

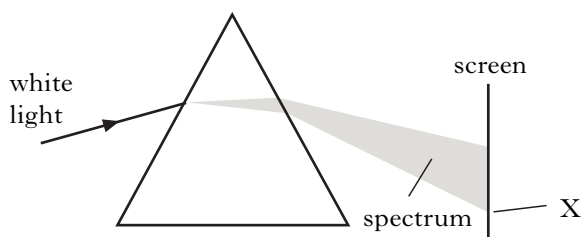

The colour observed at X is noted.

The prism is then replaced by a grating to produce spectra as shown.

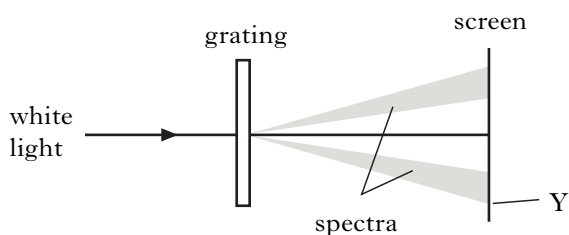

The colour observed at Y is noted.

Which row in the table gives the colour and wavelength of the light observed at X and the light observed at Y?

	Colour of light at X	Wavelength of light at X/nm	Colour of light at Y	Wavelength of light at Y/nm
A	Red	450	Red	450
B	Blue	450	Blue	450
C	Blue	650	Red	450
D	Blue	450	Red	650
E	Red	650	Blue	450

15. A ray of monochromatic light passes into a glass block as shown.

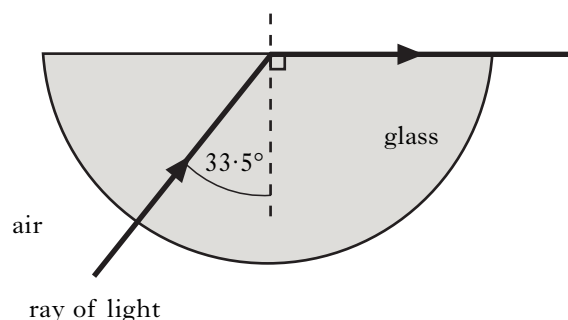

The refractive index of the glass for this light is

- A 0.03
- B 0.55
- C 0.87
- D 1.20
- E 1.81.

16. Which of the following statements about the characteristics of laser light is/are true?

- I It is monochromatic since all the photons have the same frequency.
- II It is coherent because all the photons are in phase.
- III Its irradiance is inversely proportional to the square of the distance from the source.

- A I only
- B I and II only
- C I and III only
- D II and III only
- E I, II and III

17. A student writes the following statements about p-type semiconductor material.

- I Most charge carriers are positive.
- II The p-type material has a positive charge.
- III Impurity atoms in the material have 3 outer electrons.

Which of these statements is/are true?

- A I only
- B II only
- C I and II only
- D I and III only
- E I, II and III

18. A p-n junction diode is forward biased.

Positive and negative charge carriers recombine in the junction region. This causes the emission of

- A a hole
- B an electron
- C an electron-hole pair
- D a proton
- E a photon.

19. A sample of radioactive material has a mass of 20 g. There are 48 000 nuclear decays every minute in this sample.

The activity of the sample is

- A 800 Bq
- B 2400 Bq
- C 48 000 Bq
- D 2 400 000 Bq
- E 2 880 000 Bq.

20. A sample of body tissue is irradiated by two different types of radiation, X and Y.

The table gives the radiation weighting factor and absorbed dose for each radiation.

<i>Type of radiation</i>	<i>Radiation weighting factor</i>	<i>Absorbed dose/<math>\mu</math>Gy</i>
X	10	5
Y	5	2

The total equivalent dose received by the tissue is

- A 0.9  $\mu$ Sv
- B 4.5  $\mu$ Sv
- C 7.0  $\mu$ Sv
- D 40.0  $\mu$ Sv
- E 60.0  $\mu$ Sv.

**[Turn over**

## SECTION B

Write your answers to questions 21 to 30 in the answer book.

*Marks*

21. A basketball player throws a ball with an initial velocity of  $6.5 \text{ m s}^{-1}$  at an angle of  $50^\circ$  to the horizontal. The ball is  $2.3 \text{ m}$  above the ground when released.

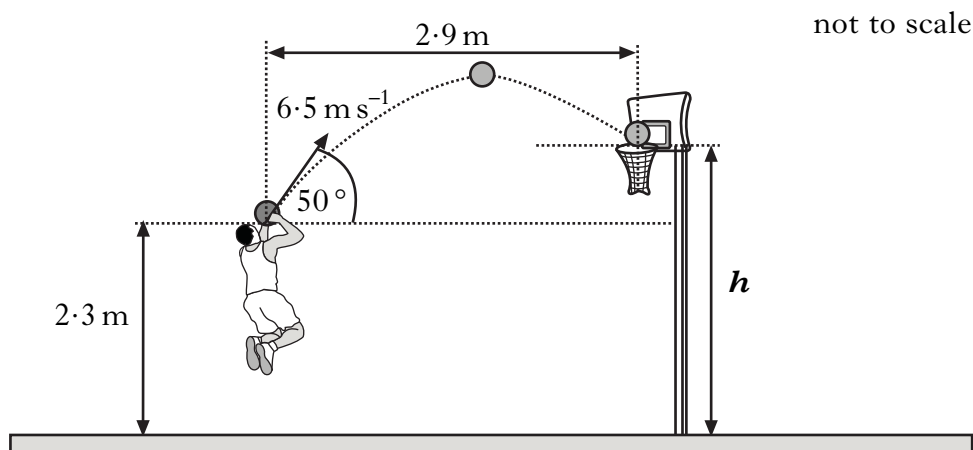

The ball travels a horizontal distance of  $2.9 \text{ m}$  to reach the top of the basket. The effects of air resistance can be ignored.

- (a) Calculate:
- (i) the horizontal component of the initial velocity of the ball; 1
  - (ii) the vertical component of the initial velocity of the ball. 1
- (b) Show that the time taken for the ball to reach the basket is  $0.69 \text{ s}$ . 1
- (c) Calculate the height  $h$  of the top of the basket. 2
- (d) A student observing the player makes the following statement.
- “The player should throw the ball with a higher speed at the same angle. The ball would then land in the basket as before but it would take a shorter time to travel the  $2.9 \text{ metres}$ .”*
- Explain** why the student’s statement is incorrect. 2
- (7)**

22. Golf clubs are tested to ensure they meet certain standards.

- (a) In one test, a securely held clubhead is hit by a small steel pendulum. The time of contact between the clubhead and the pendulum is recorded.

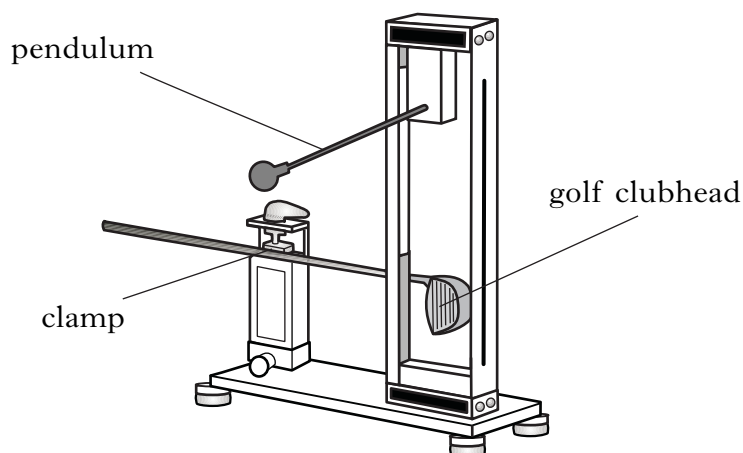

The experiment is repeated several times.

The results are shown.

248  $\mu\text{s}$       259  $\mu\text{s}$       251  $\mu\text{s}$       263  $\mu\text{s}$       254  $\mu\text{s}$

- (i) Calculate:

(A) the mean contact time between the clubhead and the pendulum; **1**

(B) the approximate absolute random uncertainty in this value. **1**

- (ii) In this test, the standard required is that the maximum value of the mean contact time must not be greater than 257  $\mu\text{s}$ .

Does the club meet this standard?

You must justify your answer. **1**

- (b) In another test, a machine uses a club to hit a stationary golf ball.

The mass of the ball is  $4.5 \times 10^{-2} \text{ kg}$ . The ball leaves the club with a speed of  $50.0 \text{ m s}^{-1}$ . The time of contact between the club and ball is 450  $\mu\text{s}$ .

- (i) Calculate the average force exerted on the ball by the club. **2**

- (ii) The test is repeated using a different club and an identical ball. The machine applies the same average force on the ball but with a longer contact time.

What effect, if any, does this have on the speed of the ball as it leaves the club?

Justify your answer. **2**

**(7)**

23. A student is training to become a diver.

- (a) The student carries out an experiment to investigate the relationship between the pressure and volume of a fixed mass of gas using the apparatus shown.

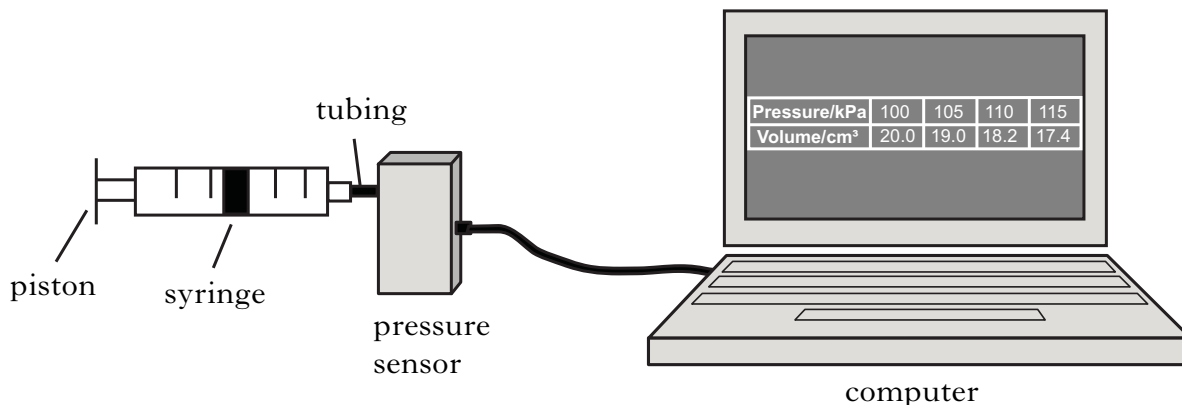

The pressure of the gas is recorded using a pressure sensor connected to a computer. The volume of the gas is also recorded. The student pushes the piston to alter the volume and a series of readings is taken. The temperature of the gas is constant during the experiment.

The results are shown.

<i>Pressure/kPa</i>	100	105	110	115
<i>Volume/cm<sup>3</sup></i>	20.0	19.0	18.2	17.4

- (i) Using **all** the data, establish the relationship between the pressure and volume of the gas. 2
- (ii) Use the kinetic model to explain the change in pressure as the volume of gas decreases. 2
- (b) (i) The density of water in a loch is  $1.02 \times 10^3 \text{ kg m}^{-3}$ . Atmospheric pressure is  $1.01 \times 10^5 \text{ Pa}$ .  
Show that the **total** pressure at a depth of 12.0 m in this loch is  $2.21 \times 10^5 \text{ Pa}$ . 2
- (ii) At the surface of the loch, the student breathes in a volume of  $1.50 \times 10^{-3} \text{ m}^3$  of air.  
Calculate the volume this air would occupy at a depth of 12.0 m. The mass and temperature of the air are constant. 2
- (c) At a depth of 12.0 m, the diver fills her lungs with air from her breathing apparatus. She then swims to the surface.  
Explain why it would be dangerous for her to hold her breath while doing this. 2

(10)

24. A battery of e.m.f.  $6.0\text{ V}$  and internal resistance,  $r$ , is connected to a variable resistor  $R$  as shown.

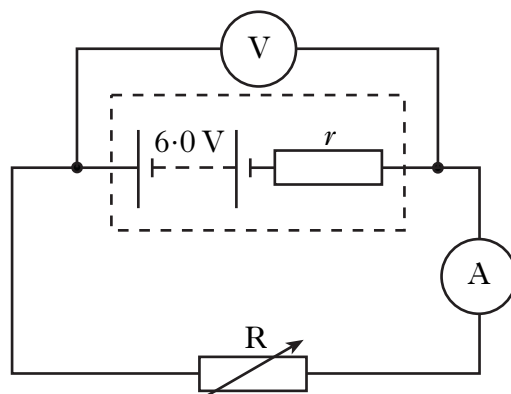

The graph shows how the current in the circuit changes as the resistance of  $R$  increases.

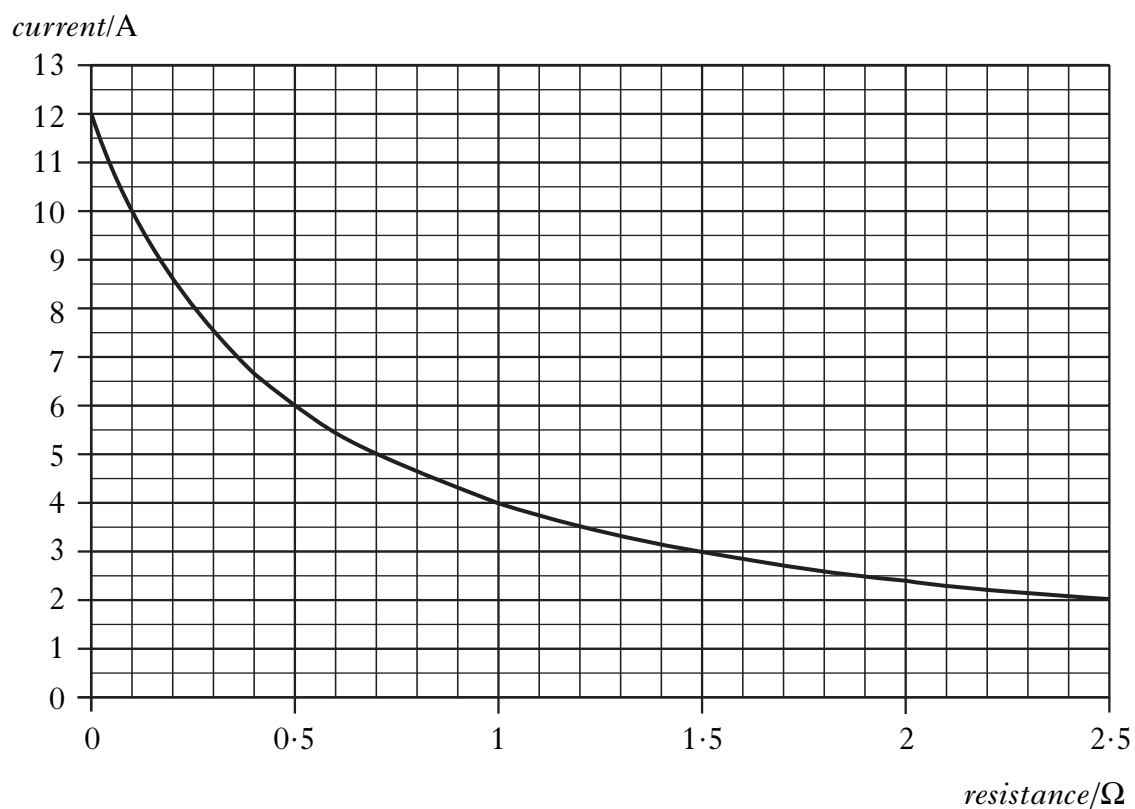

- (a) Use information from the graph to calculate:
- the lost volts in the circuit when the resistance of  $R$  is  $1.5\ \Omega$ ; 2
  - the internal resistance,  $r$ , of the battery. 2
- (b) The resistance of  $R$  is now increased.
- What effect, if any, does this have on the lost volts?
- You must justify your answer. 2
- (6)**

25. (a) A microphone is connected to the input terminals of an oscilloscope. A tuning fork is made to vibrate and held close to the microphone as shown.

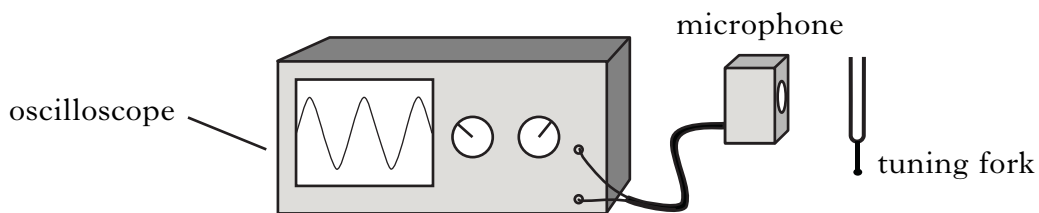

The following diagram shows the trace obtained and the settings on the oscilloscope.

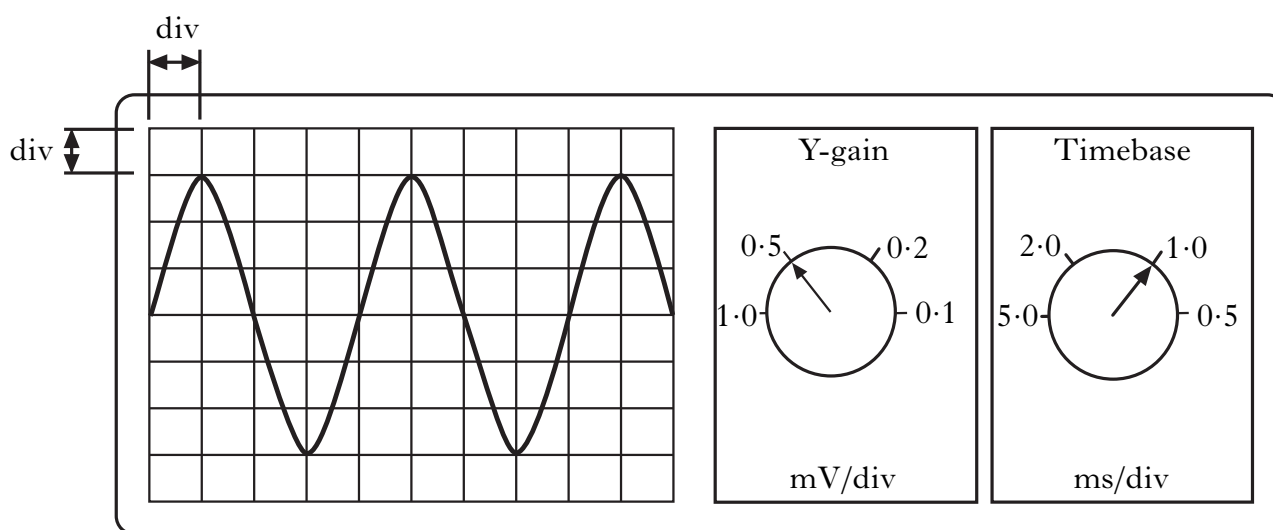

Calculate:

- |                                     |          |
|-------------------------------------|----------|
| (i) the peak voltage of the signal; | <b>1</b> |
| (ii) the frequency of the signal.   | <b>2</b> |

## 25. (continued)

- (b) To amplify the signal from the microphone, it is connected to an op-amp circuit. The oscilloscope is now connected to the output of the amplifier as shown.

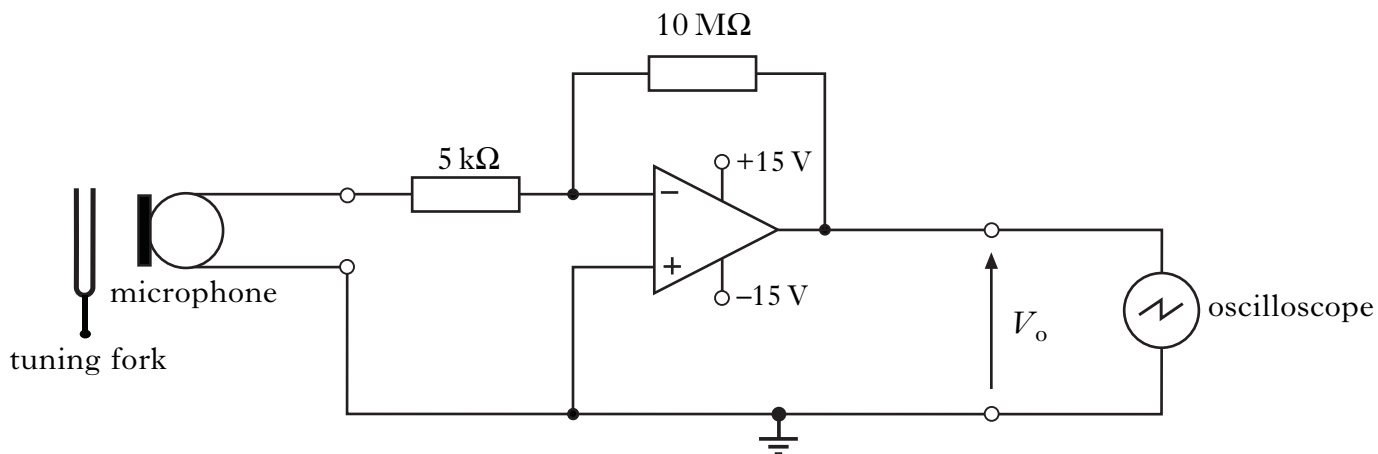

The settings of the oscilloscope are adjusted to show a trace of the amplified signal.

- (i) In which mode is this op-amp being used? 1
- (ii) The peak voltage from the microphone is now  $6.2 \text{ mV}$ .  
Calculate the **r.m.s.** value of the output voltage,  $V_o$ , of the op-amp. 3
- (iii) With the same input signal and settings on the oscilloscope, the supply voltage to the op-amp is now reduced from  $\pm 15 \text{ V}$  to  $\pm 9 \text{ V}$ .  
What effect does this change have on the trace on the oscilloscope?  
Justify your answer. 2
- (9)**

[Turn over

26. A 12 volt battery of negligible internal resistance is connected in a circuit as shown.

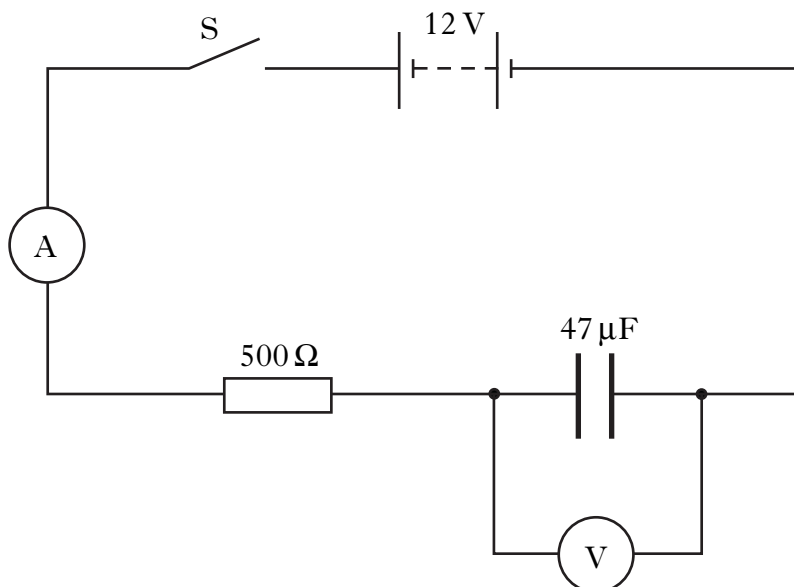

The capacitor is initially uncharged. Switch S is then closed and the capacitor starts to charge.

- (a) Sketch a graph of the current against time from the instant switch S is closed. Numerical values are not required. 1
- (b) At one instant during the charging of the capacitor the reading on the ammeter is 5.0 mA.  
Calculate the reading on the voltmeter at this instant. 3
- (c) Calculate the **maximum** energy stored in the capacitor in this circuit. 2
- (d) The 500Ω resistor is now replaced with a 2.0 kΩ resistor.  
What effect, if any, does this have on the maximum energy stored in the capacitor?  
Justify your answer. 2
- (8)**

27. A laser produces a narrow beam of monochromatic light.

(a) Red light from a laser passes through a grating as shown.

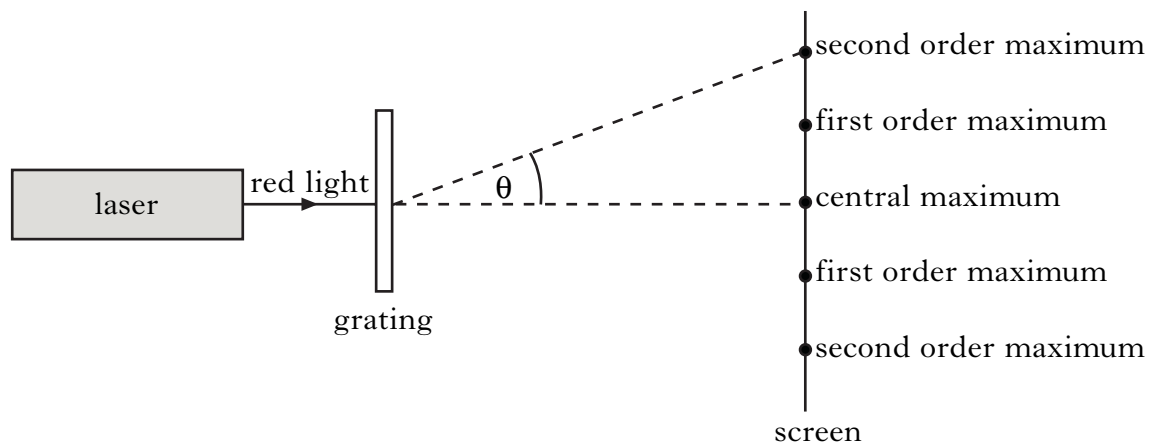

A series of maxima and minima is observed.

Explain in terms of waves how a **minimum** is produced.

1

(b) The laser is now replaced by a second laser, which emits blue light.

Explain why the observed maxima are now closer together.

1

(c) The wavelength of the blue light from the second laser is  $4.73 \times 10^{-7}$  m.  
The spacing between the lines on the grating is  $2.00 \times 10^{-6}$  m.

Calculate the angle between the central maximum and the second order maximum.

2

(4)

[Turn over

28. (a) Electrons which orbit the nucleus of an atom can be considered as occupying discrete energy levels.

The following diagram shows some of the energy levels for a particular atom.

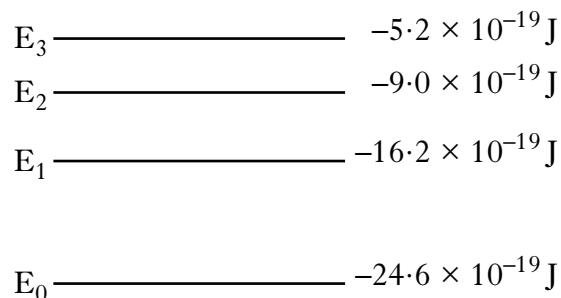

- (i) Radiation is produced when electrons make transitions from a higher to a lower energy level.

Which transition, between these energy levels, produces radiation with the shortest wavelength?

Justify your answer.

2

- (ii) An electron is excited from energy level  $E_2$  to  $E_3$  by absorbing light energy.

What frequency of light is used to excite this electron?

2

- (b) Another source of light has a frequency of  $4.6 \times 10^{14} \text{ Hz}$  in air.

A ray of this light is directed into a block of transparent material as shown.

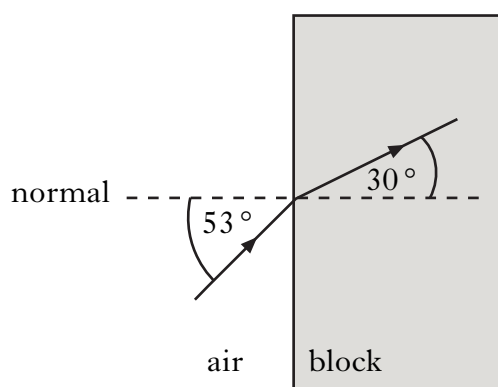

Calculate the wavelength of the light in the block.

3

(7)

29. Ultraviolet radiation from a lamp is incident on the surface of a metal.  
This causes the release of electrons from the surface of the metal.

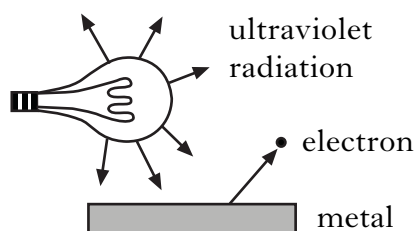

The energy of each photon of ultraviolet light is  $5.23 \times 10^{-19} \text{ J}$ .

The work function of the metal is  $2.56 \times 10^{-19} \text{ J}$ .

(a) Calculate:

- (i) the maximum kinetic energy of an electron released from this metal by this radiation; 1
- (ii) the maximum speed of an emitted electron. 2

(b) The source of ultraviolet radiation is now moved further away from the surface of the metal.

State the effect, if any, this has on the maximum speed of an emitted electron.

Justify your answer.

2  
(5)

**[Turn over**

30. (a) Some power stations use nuclear fission reactions to provide energy for generating electricity. The following statement represents a fission reaction.

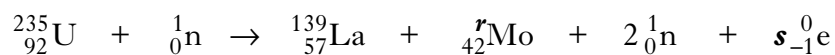

- (i) Determine the numbers represented by the letters *r* and *s* in the above statement. 1
- (ii) Explain why a nuclear fission reaction releases energy. 1
- (iii) The masses of the particles involved in the reaction are shown in the table.

<i>Particle</i>	<i>Mass/kg</i>
${}_{92}^{235}\text{U}$	$390.173 \times 10^{-27}$
${}_{57}^{139}\text{La}$	$230.584 \times 10^{-27}$
${}_{42}^r\text{Mo}$	$157.544 \times 10^{-27}$
${}_0^1\text{n}$	$1.675 \times 10^{-27}$
${}_{-1}^0\text{e}$	negligible

Calculate the energy released in this reaction.

3

**30. (continued)**

(b) One method of reducing the radiation received by a person is by using lead shielding.

In an investigation of the absorption of gamma radiation by lead, the following graph of corrected count rate against thickness of lead is obtained.

*corrected count rate/counts per minute*

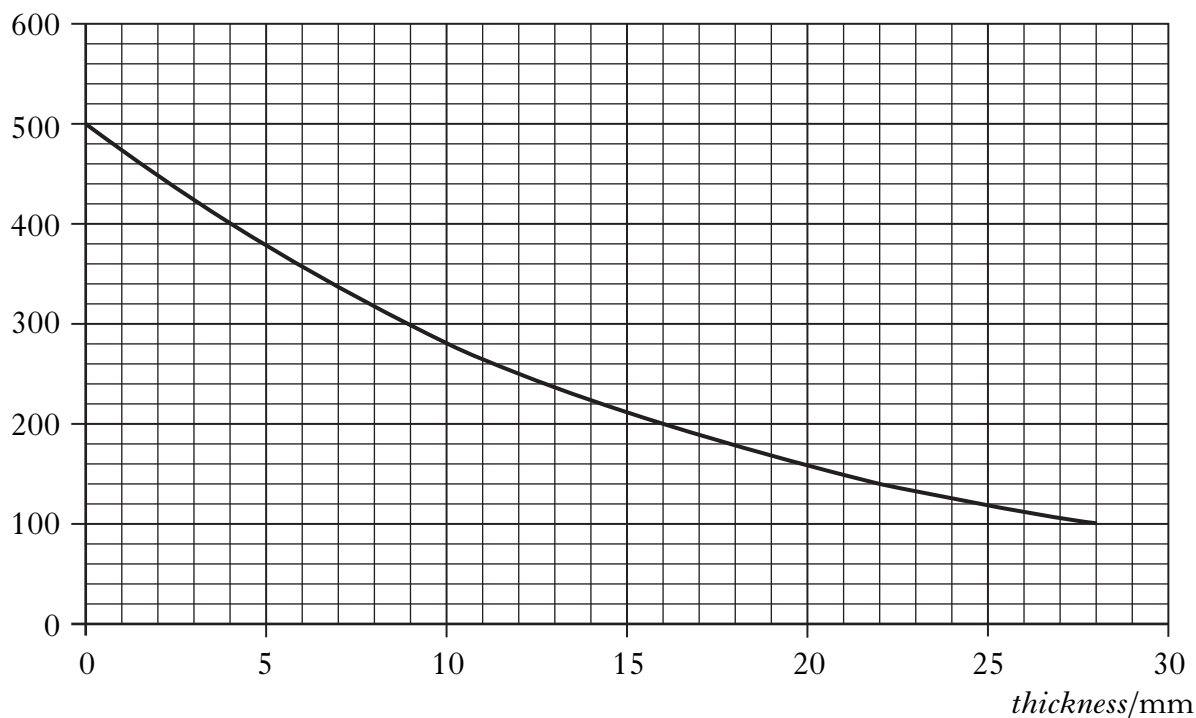

- (i) Determine the half-value thickness of lead for this radiation. **1**
- (ii) With no shielding, the equivalent dose rate a short distance from this source is  $200 \mu\text{Sv h}^{-1}$ .

When the source is stored in a lead container, the equivalent dose rate at the same distance falls to  $50 \mu\text{Sv h}^{-1}$ .

Calculate the thickness of the lead container. **1**

**(7)**

[END OF QUESTION PAPER]

**[BLANK PAGE]**

**[BLANK PAGE]**

**[BLANK PAGE]**