

# Engineering Science Data Booklet

## Higher

For use in National Qualification Courses  
leading to the 2015 examinations and beyond.

Publication date: 2014  
Publication code: BB6754  
ISBN: 978 1 910180 01 3

Published by the Scottish Qualifications Authority  
The Optima Building, 58 Robertson Street, Glasgow G2 8DQ  
Lowden, 24 Wester Shawfair, Dalkeith, Midlothian EH22 1FD

[www.sqa.org.uk](http://www.sqa.org.uk)

*The information in this publication may be reproduced in support of SQA qualifications. If it is reproduced, SQA should be clearly acknowledged as the source. If it is to be used for any other purpose, then written permission must be obtained from SQA. It must not be reproduced for trade or commercial purposes.*

For an up-to-date list of prices visit the **Publication Sales and Downloads** section of SQA's website.  
For further details telephone SQA's Customer Contact Centre on 0845 279 1000.

## Contents

Preface . . . . .	3
Quantities, symbols and units . . . . .	4
Decimal prefixes . . . . .	5
Energy and power formulae . . . . .	5
Mechanisms . . . . .	5
Pneumatic Systems . . . . .	6
Structures . . . . .	6
Properties of materials. . . . .	6
Electrical and electronic formulae . . . . .	7
Transistors . . . . .	7
Typical operational amplifier circuits . . . . .	8–10

### Preface

This data booklet is intended for use by candidates in examinations in Engineering Science at Higher. It may also be used as a reference for assignments at Higher. It is recommended that candidates should become familiar with the contents of the data booklet through use in undertaking Units of these Courses.

It should be noted that the range of data contained in the booklet has been limited to the concepts which may be assessed through written question papers. This range should be supplemented by other resource material as necessary during the course, eg by using data sheets. However, should any additional information (or data not included in this booklet) be required in an examination, such information will be included in the question paper.

Teachers/lecturers should note that all of the material contained in this booklet is likely to be examined at some time. With regard to tables of information, not every entry in a table will necessarily be involved in examination questions.

From the variety of data offered in this booklet, candidates will be expected to demonstrate the ability to select appropriate information or formulae.

## Quantities, Symbols and Units

Quantity	Symbol	Unit	Abbreviation
distance	d,x	metre	m
height	h	metre	m
length	l	metre	m
diameter	d	metre	m
radius	r	metre	m
area	A	square metre	m <sup>2</sup>
circumference	C	metre	m
time	t	second	s
speed, velocity	v	metre per second	ms <sup>-1</sup>
mass	m	kilogram	kg
force	F	newton	N
gravitational acceleration	g	metre per second per second	ms <sup>-2</sup>
work done	E <sub>W</sub>	joule	J
energy	E	joule	J
power	P	watt	W
torque	T	newton metre	Nm
efficiency	η	-	-
pressure	P	newton per square metre	Nm <sup>-2</sup>
temperature	T	kelvin, celsius	K, °C
specific heat capacity	c	joule per kilogram per degree kelvin	Jkg <sup>-1</sup> K <sup>-1</sup>
voltage, potential difference	V	volt	V
current	I	ampere (amp)	A
resistance	R	ohm	Ω
frequency	f	hertz	Hz
rotational speed	n	revolutions per minute	revs min <sup>-1</sup>
		revolutions per second	revs sec <sup>-1</sup>
stress	σ	newton per square metre	Nm <sup>-2</sup>
strain	ε	-	-

## Decimal Prefixes

Prefix	Symbol	Multiplying factor
peta	P	$10^{15}$
tera	T	$10^{12}$
giga	G	$10^9$
mega	M	$10^6$
kilo	k	$10^3$
milli	m	$10^{-3}$
micro	$\mu$	$10^{-6}$
nano	n	$10^{-9}$
pico	p	$10^{-12}$

## Relationships

### Energy and power

Potential energy	$E_p = mgh$	$g = 9.8 \text{ ms}^{-2}$ (to 2 significant figures)
Kinetic energy	$E_k = \frac{1}{2} mv^2$	
Heat energy	$E_h = cm\Delta T$	$c_{\text{water}} = 4200 \text{ Jkg}^{-1}\text{K}^{-1}$ (to 2 significant figures)
Electrical energy	$E_e = VIt$	
Work done	$E_w = Fd$	
Power	$P = \frac{E}{t}$	
Electrical power	$P = VI = \frac{V^2}{R} = I^2R$	
Mechanical power	$P = Fv$	$P = 2\pi nT$ (n = no of revs per second)
Efficiency	$\eta = \frac{\text{Energy}_{\text{out}}}{\text{Energy}_{\text{in}}} = \frac{\text{Power}_{\text{out}}}{\text{Power}_{\text{in}}}$	

### Mechanisms

Velocity ratio	$VR = \frac{\text{speed of input}}{\text{speed of output}}$		
	Input speed x input size = output speed x output size		
Torque	$T = Fr$		
Circumference of circle	$C = \pi d$		
Moment of force	$M = Fx$	(x is perpendicular distance)	
Principle of moments	$\Sigma M = 0$ $\Sigma \text{ clockwise moments} = \Sigma \text{ anti-clockwise moments}$		
Conditions of equilibrium	$\Sigma F_h = 0$	$\Sigma F_v = 0$	$\Sigma M = 0$

## Pneumatic Systems

Pressure, force and area  $P = \frac{F}{A}$

Area of circle  $A = \pi r^2$        $A = \frac{\pi d^2}{4}$

$\pi = 3.14$  (to 3 significant figures)

## Structures

Stress  $\sigma = \frac{F}{A}$

Strain  $\epsilon = \frac{\Delta l}{l}$

Young's Modulus  $E = \frac{\sigma}{\epsilon}$

Factor of Safety =  $\frac{\text{ultimate load}}{\text{safe working load}}$

## Properties of materials

Material	Young's Modulus E kNmm <sup>-2</sup>	Yield stress $\sigma_y$ kNmm <sup>-2</sup>	Ultimate tensile stress Nmm <sup>-2</sup>	Ultimate compressive stress Nmm <sup>-2</sup>
Mild steel	196	220	430	430
Stainless steels	190-200	286-500	760-1280	460-540
Low-alloy steels	200-207	500-1980	680-2400	680-2400
Cast iron	120	-	120-160	600-900
Aluminium alloy	70	250	300	300
Titanium alloy	110	950	1000	1000
Nickel alloys	130-234	200-1600	400-2000	400-2000
Concrete	-	-	-	60
Concrete (steel reinforced)	45-50	-	-	100
Concrete (post stressed)	-	-	-	100
Plastic, ABS polycarbonate	2.6	55	60	85
Plastic, polypropylene	0.9	19-36	33-36	70
Wood, parallel to grain	9-16	-	55-100	6-16
Wood, perpendicular to grain	0.6-1.0	-	-	2-6

## Electrical and electronic

Ohm's Law

$$V = IR$$

Resistors in series

$$R_t = R_1 + R_2 + R_3 + \dots$$

Resistors in parallel

$$\frac{1}{R_t} = \frac{1}{R_1} + \frac{1}{R_2} + \frac{1}{R_3} + \dots$$

2 resistors in parallel

$$R_t = \frac{R_1 R_2}{(R_1 + R_2)}$$

Kirchhoff's 1st law

$$\Sigma I = 0 \text{ (algebraic sum of currents at a node is zero)}$$

Kirchhoff's 2nd law

$$\Sigma E = \Sigma IR$$

(algebraic sum of supply voltages = sum of voltage-drops, in a closed loop)

Voltage Divider

$$\frac{V_1}{V_2} = \frac{R_1}{R_2}$$

Electrical power

$$P = VI = \frac{V^2}{R} = I^2 R$$

## Transistors

Bi-polar transistor gain

$$h_{FE} = I_c / I_b$$

MOSFET transconductance

$$g_m = \Delta I_d / \Delta V_{gs}$$

## MOSFET Characteristics Curves

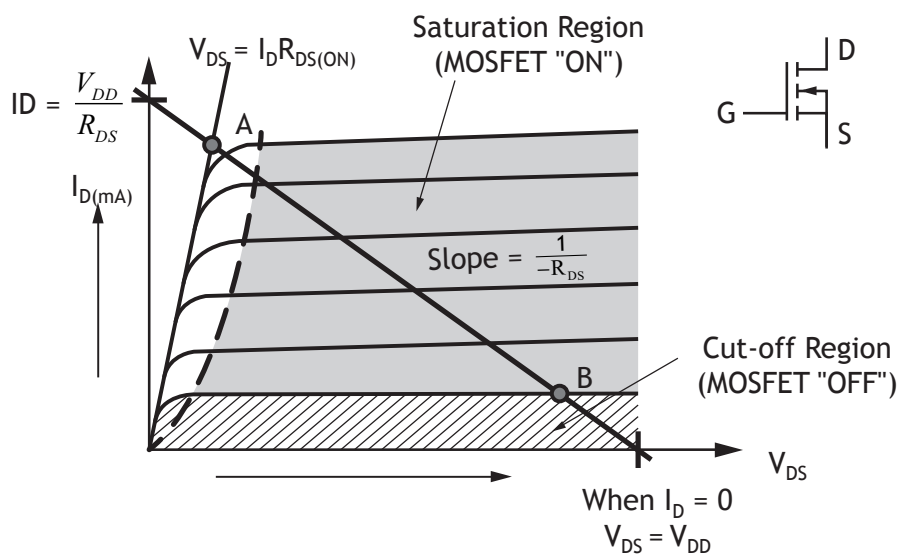

## Typical operational amplifier circuits

$V_o$  = output voltage

$V_i$  = input voltage

$V_{cc}$  = supply voltage

$R_f$  = feedback resistance

$R_i$  = input resistance

$A_v$  = gain =  $\frac{\text{output voltage}}{\text{input voltage}}$

Note : Op-amp output saturates at 85% of  $V_{cc}$

---

### Inverting

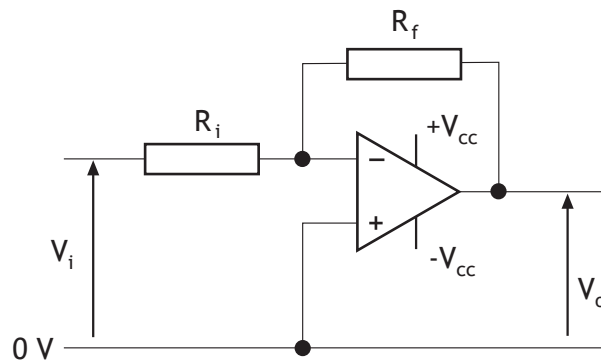

$$A_v = \frac{V_o}{V_i}$$

$$A_v = -\frac{R_f}{R_i}$$

$$V_o = -\frac{R_f}{R_i} V_i$$

---

### Non-inverting

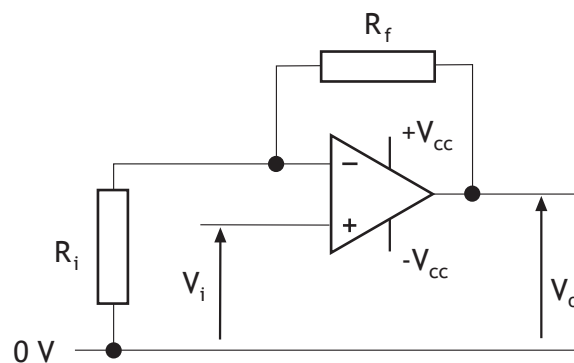

$$A_v = \frac{V_o}{V_i}$$

$$A_v = 1 + \frac{R_f}{R_i}$$

$$V_o = \left(1 + \frac{R_f}{R_i}\right) V_i$$



## Comparator

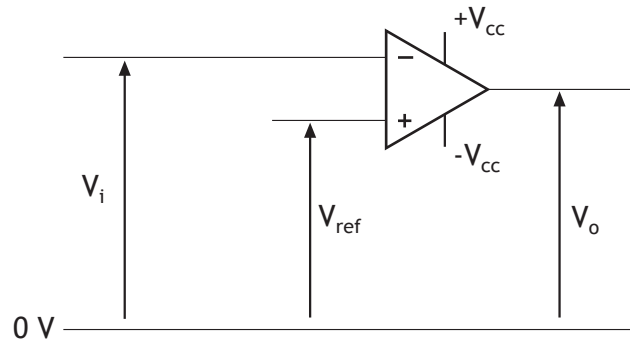

If  $V_i < V_{ref}$ , then  $V_o$  saturates positively (85% of  $+V_{cc}$ )

If  $V_i > V_{ref}$ , then  $V_o$  saturates negatively (85% of  $-V_{cc}$ )

## Difference Amplifier

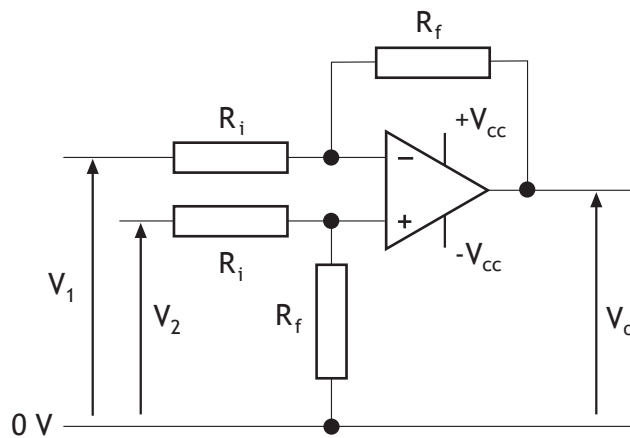

$$A_v = \frac{V_o}{(V_2 - V_1)}$$

$$A_v = \frac{R_f}{R_i}$$

$$V_o = \frac{R_f}{R_i}(V_2 - V_1)$$

## Summing Amplifier

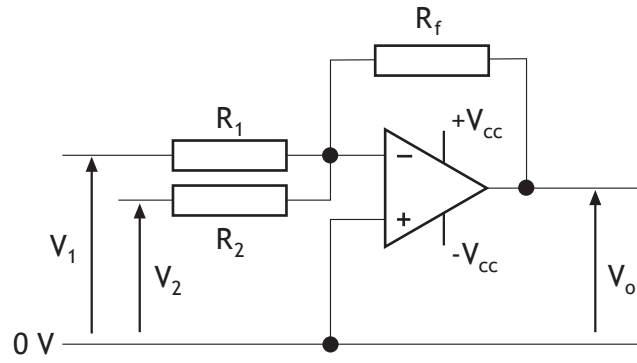

$$A_{v1} = - \frac{R_f}{R_1} \quad A_{v2} = - \frac{R_f}{R_2} \quad A_{vn} = - \frac{R_f}{R_n}$$

$$V_o = (A_{v1} V_1) + (A_{v2} V_2) + \dots$$

$$V_o = - R_f \left( \frac{V_1}{R_1} + \frac{V_2}{R_2} + \dots \right)$$

## Voltage Follower

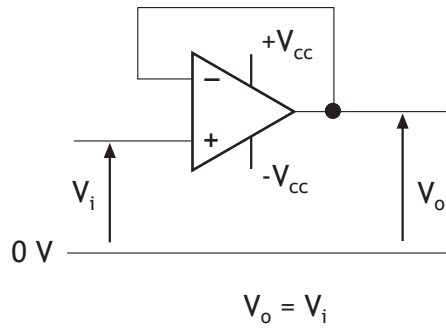

[END OF DATA BOOKLET]