

FOR OFFICIAL USE

--	--	--	--	--	--

--

Total Marks

**X069/101**

NATIONAL  
QUALIFICATIONS  
2009

TUESDAY, 26 MAY  
1.00 PM – 2.30 PM

PHYSICS  
INTERMEDIATE 1

Fill in these boxes and read what is printed below.

Full name of centre

--

Town

--

Forename(s)

--

Surname

--

Date of birth

Day Month Year

--	--	--	--	--	--	--	--

Scottish candidate number

--	--	--	--	--	--	--	--	--	--

Number of seat

--

Reference may be made to the Physics Data Booklet.

**Section A – Questions 1–20 (20 marks)**

Instructions for completion of **Section A** are given on page two.

For this section of the examination you must use an **HB pencil**.

**Section B (60 marks)**

All questions should be attempted.

The questions may be answered in any order but all answers are to be written in the spaces provided in this answer book, **and must be written clearly and legibly in ink**.

Rough work, if any should be necessary, should be written in this book, and then scored through when the fair copy has been written. If further space is required, a supplementary sheet for rough work may be obtained from the invigilator.

Additional space for answers will be found at the end of the book. If further space is required, supplementary sheets may be obtained from the invigilator and should be inserted inside the **front** cover of this booklet.

Before leaving the examination room you must give this book to the invigilator. If you do not, you may lose all the marks for this paper.



## SECTION A

- 1 Check that the answer sheet provided is for Physics Intermediate 1 (Section A).
- 2 For this section of the examination you must use an **HB pencil** and, where necessary, an eraser.
- 3 Check that the answer sheet you have been given has **your name, date of birth, SCN** (Scottish Candidate Number) and **Centre Name** printed on it.  
Do not change any of these details.
- 4 If any of this information is wrong, tell the Invigilator immediately.
- 5 If this information is correct, **print** your name and seat number in the boxes provided.
- 6 The answer to each question is **either** A, B, C, D or E. Decide what your answer is, then, using your pencil, put a horizontal line in the space provided (see sample question below).
- 7 There is **only one correct** answer to each question.
- 8 Any rough working should be done on the question paper or the rough working sheet, **not** on your answer sheet.
- 9 At the end of the exam, put the **answer sheet for Section A inside the front cover of this answer book.**

### Sample Question

The energy unit measured by the electricity meter in your home is the

- A kilowatt-hour
- B ampere
- C watt
- D coulomb
- E volt.

The correct answer is **A**—kilowatt-hour. The answer **A** has been clearly marked in **pencil** with a horizontal line (see below).

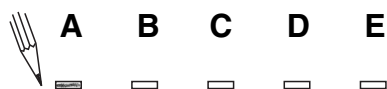

### Changing an answer

If you decide to change your answer, carefully erase your first answer and, using your pencil, fill in the answer you want. The answer below has been changed to **E**.

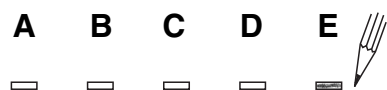

**SECTION A**

**Answer questions 1–20 on the answer sheet.**

1. In a radio receiver the amplifier
- A detects all radio waves
  - B selects one frequency of radio wave
  - C makes electrical signals bigger
  - D changes electrical energy into sound energy
  - E changes sound energy into electrical energy.
2. Frequency is measured in
- A seconds
  - B decibels
  - C metres per second
  - D hertz
  - E amperes.

3. A block diagram of a television set is shown below. Some of the components have been named.

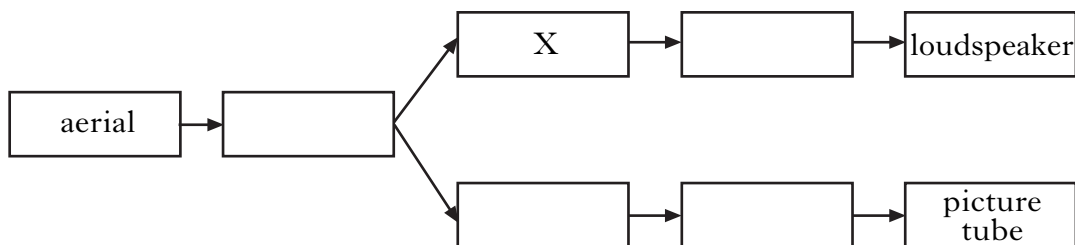

What is component X?

- A Tuner
- B Sound decoder
- C Vision decoder
- D Sound amplifier
- E Vision amplifier

**[Turn over**

4. The diagram shows a signal approaching a curved reflector.

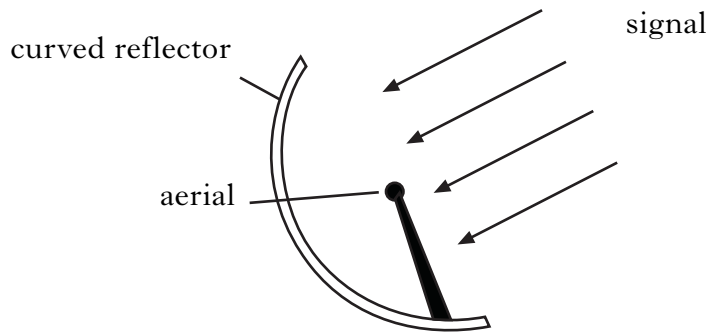

The curved reflector

- A makes the signal smaller at the aerial
  - B increases the frequency of the signal at the aerial
  - C makes the signal stronger at the aerial
  - D makes the signal weaker at the aerial
  - E decreases the frequency of the signal at the aerial.
5. A circuit is set up.

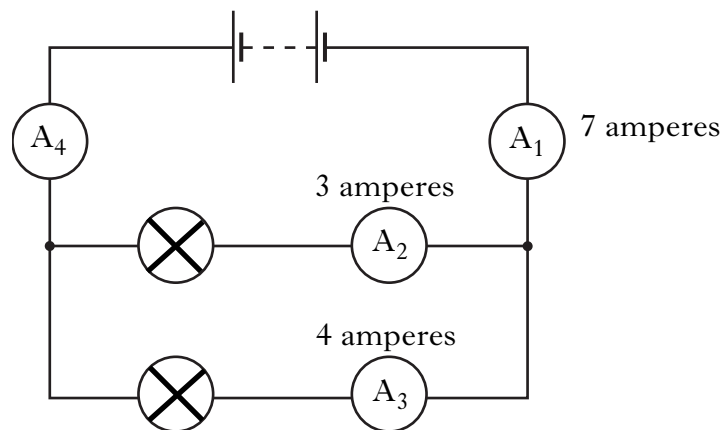

The readings on ammeters  $A_1$ ,  $A_2$  and  $A_3$  are shown.

The reading on ammeter  $A_4$  is

- A 1 ampere
- B 7 amperes
- C 10 amperes
- D 11 amperes
- E 14 amperes.

6. Mains voltage in Scotland is

- A 1.5 volts
- B 12 volts
- C 110 volts
- D 230 volts
- E 325 volts.

7. Four resistors are connected in parallel as shown.

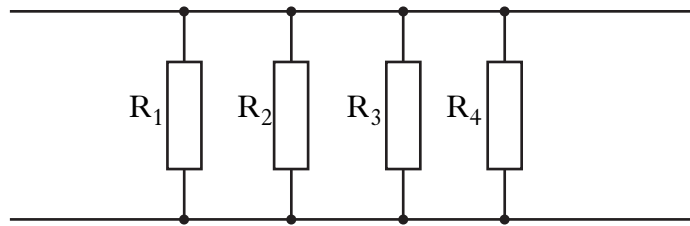

The voltage across resistor R<sub>1</sub> is 12 volts.

Which row in the table shows the voltage across each of the other three resistors?

	<i>voltage across R<sub>2</sub> in volts</i>	<i>voltage across R<sub>3</sub> in volts</i>	<i>voltage across R<sub>4</sub> in volts</i>
A	4	4	4
B	6	3	3
C	12	6	3
D	12	6	6
E	12	12	12

8. Heat can also be known as

- A ultraviolet radiation
- B infrared radiation
- C microwave radiation
- D gamma radiation
- E X-ray radiation.

**[Turn over**

9. A student writes the following statements about gamma rays.

- I Gamma rays can pass through most materials.
- II Gamma rays can kill living cells.
- III Gamma rays are invisible to the naked eye.

Which of the statements is/are correct?

- A I only
- B II only
- C III only
- D I and III only
- E I, II and III

10. The strength of a source of gamma radiation is 500 units.

After two years the strength of the source could be

- A 250 units
- B 500 units
- C 1000 units
- D 2000 units
- E 4000 units.

11. Two notes are an octave apart if

- A the notes are the same frequency
- B the notes are the same loudness
- C one note is twice the amplitude of the other
- D one note is half the loudness of the other
- E one note is twice the frequency of the other.

12. High frequency sounds that are beyond the range of human hearing are called

- A microwaves
- B infrasounds
- C ultrasounds
- D long wave
- E treble.

13. A student investigates sound waves.

She connects a microphone to an oscilloscope. The microphone detects a sound and the following trace is seen on the oscilloscope screen.

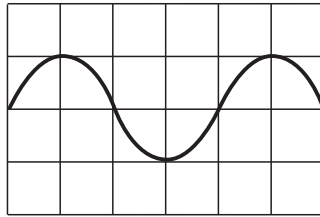

The student then uses the microphone to detect a louder sound of higher frequency. The controls of the oscilloscope are unchanged.

Which of the following shows the trace now seen on the oscilloscope screen?

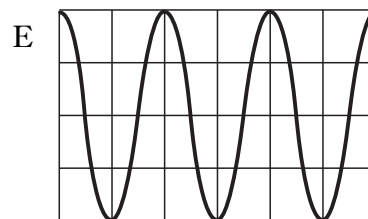
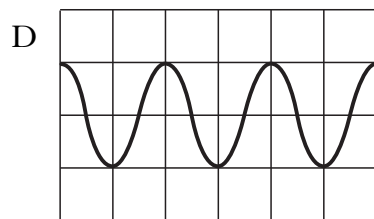
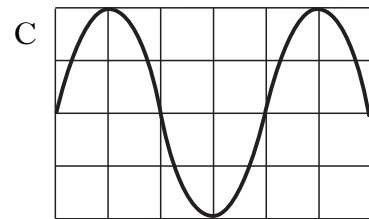
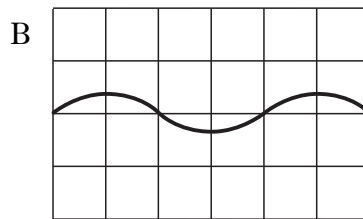
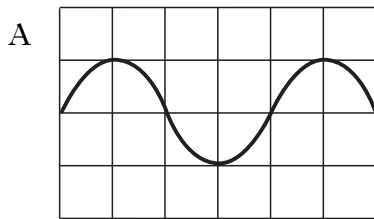

14. Two surfaces are in contact.

Which of the following materials would reduce the friction between the surfaces?

- A Sandpaper
- B Rubber
- C Concrete
- D Oil
- E Wood

**[Turn over**

15. Five cars are tested to find which one has the greatest acceleration. The time taken for each car to go from 0 – 60 miles per hour is measured. The results are shown in the table.

<i>Car</i>	<i>Time to go from 0 – 60 miles per hour</i>
P	6.2 seconds
Q	7.6 seconds
R	7.8 seconds
S	8.5 seconds
T	9.2 seconds

The car with the greatest acceleration is

- A car P
  - B car Q
  - C car R
  - D car S
  - E car T.
16. The diagram shows the forces acting on a skydiver as he falls through the air.

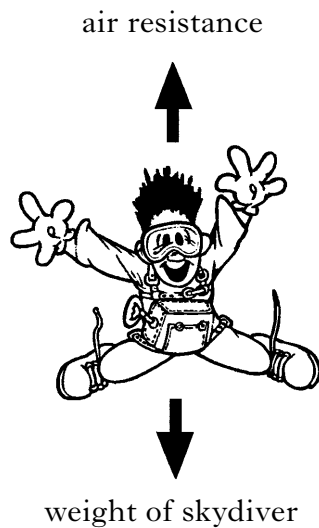

When air resistance balances the weight of the skydiver,

- A the skydiver will stop falling downwards
- B the skydiver will move downwards at a steady speed
- C the skydiver will move upwards
- D the skydiver will speed up
- E the skydiver will slow down.

17. The strength of a motorway crash barrier is tested by driving vehicles into it.

Which row in the table shows the mass and speed of the vehicle which would cause most damage to the crash barrier?

	<i>Mass of vehicle in kilograms</i>	<i>Speed of vehicle in metres per second</i>
A	800	15
B	800	20
C	800	25
D	1600	20
E	1600	25

18. The resistance of an LDR decreases when

- A temperature increases
- B temperature decreases
- C sound level increases
- D light level increases
- E light level decreases.

19. The energy change in an electronic **output** device could be

- A electrical to sound
- B sound to electrical
- C heat to light
- D light to heat
- E heat to sound.

20. Which of the following is a suitable **input** device for an electronic thermometer?

- A LED
- B Microphone
- C Thermistor
- D Buzzer
- E Ammeter

**Candidates are reminded that the answer sheet for Section A MUST be placed INSIDE the front cover of this answer book.**

**[BLANK PAGE]**

Marks

**SECTION B**

**Answer questions 21–33 in the spaces provided.**

21. (a) What is an optical fibre?

1

(b) Describe **one** advantage of an optical fibre for carrying TV signals into the home rather than using an aerial on the roof.

1

(c) Telephone signals can cross the Atlantic by metal wires or optical fibres.

(i) Two telephone signals are sent from Canada at the same time. One is sent through the metal wires, one through the optical fibres. Which signal arrives in Scotland first?

1

(ii) Explain your answer.

1

**[Turn over**

22. (a) Complete the sentences using some of these words.

Marks

**text**                      **radio**                      **electrical**  
**receiver**                **sound**                      **light**

A mobile phone acts as a transmitter and a .

A mobile phone uses  waves to send text messages.

The loudspeaker in a mobile phone changes  energy into  energy.

2

(b) A mobile phone contains an amplifier. The input voltage to the amplifier is 0.02 volts. The output voltage from the amplifier is 3.2 volts. Calculate the voltage gain of the amplifier.

2

(c) A student looks at his mobile phone and notices that the signal **strength** is very low. Give **two** reasons why this might happen.

2

*Marks*

23. (a) What type of radiation causes sun-burn?

**1**

(b) It is recommended that goggles should be worn when using a sun-bed.  
Explain why.

**1**

(c) A student goes to a mountain ski resort. The temperature is always cold but the student is advised to wear sun-block. Explain why sun-block is necessary.

**1**

(d) Why should skin not be overexposed to sunlight?

**1**

**[Turn over**

Marks

24. A student plugs a toaster, a kettle and a microwave oven into an adaptor.

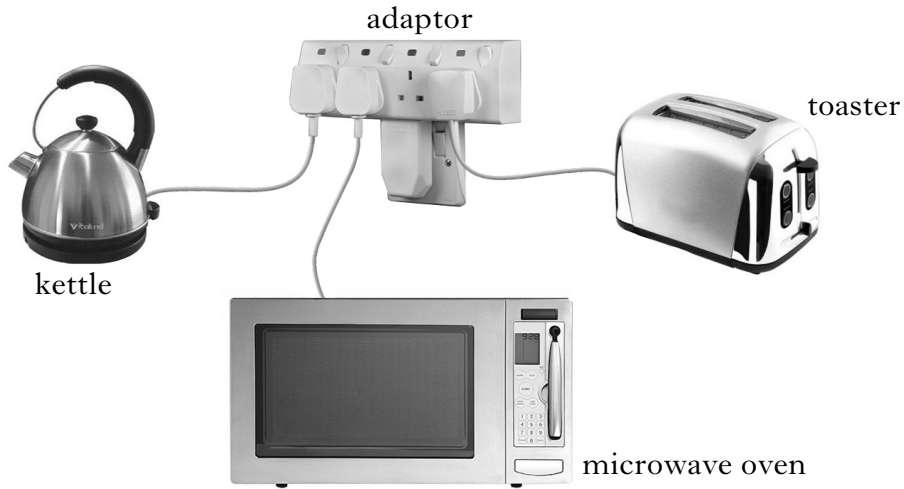

The table shows information about the appliances.

<i>Appliance</i>	<i>Voltage in volts</i>	<i>Power in watts</i>	<i>Current in amperes</i>
Microwave oven	230	690	3
Toaster	230	1150	5
Kettle	230	2070	

(a) Show by calculation that the current in the kettle is 9 amperes when operating.

You **must** show your working.

2

*Marks*

**24. (continued)**

The adaptor is fitted with a 13 ampere fuse.

- (b) (i) Which **two** appliances must **not** be switched on at the same time?

**1**

- (ii) Explain your answer.

**1**

**[Turn over**

Marks

25. A student's games console stops working. She builds the circuit below to test the fuse in the plug.

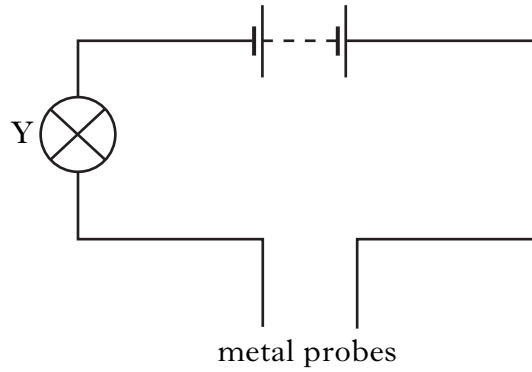

- (a) The student touches the metal probes together and bulb Y lights. She connects the metal probes to the fuse from the games console. This time bulb Y does not light. What might be wrong with the fuse?

1

- (b) The student sets up a new circuit including component X.

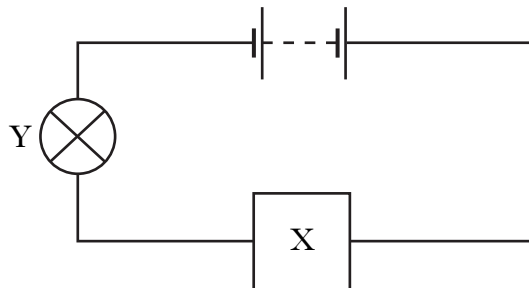

X is used to vary the brightness of bulb Y. What is component X?

1

Marks

**25. (continued)**

- (c) The student adds an ammeter to the circuit in (b) to measure the current. Draw this new circuit including the ammeter and the correct symbol for component X.



2

- (d) The voltage of the battery in the circuit is 6 volts. The ammeter shows a current of 0.1 amperes. Calculate the resistance of the circuit.

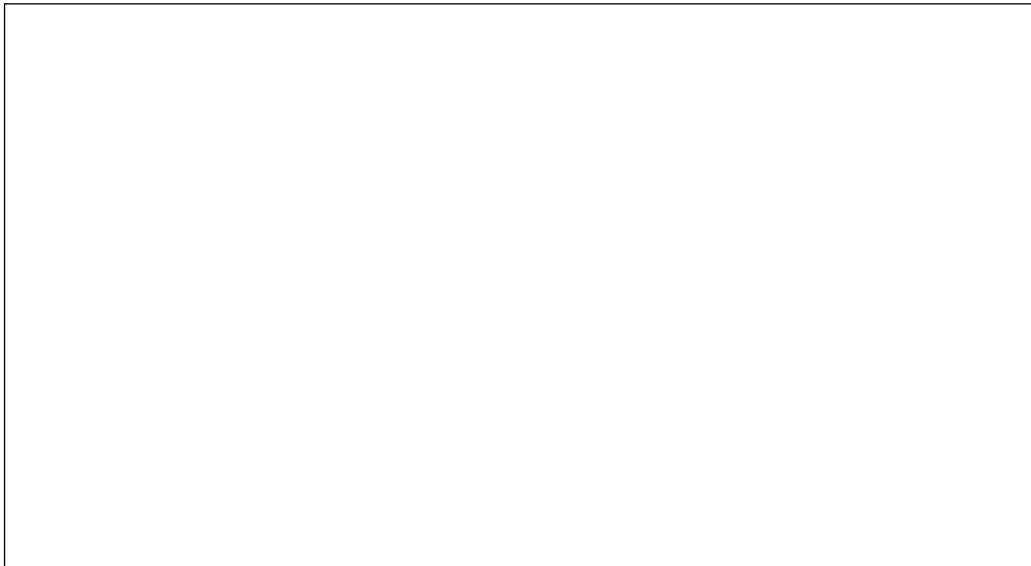

2

**[Turn over**

Marks

26. (a) Complete the diagrams to show the paths of the rays of light through each lens.

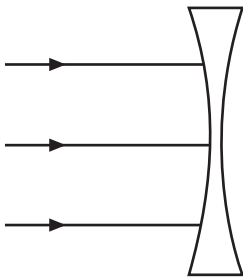
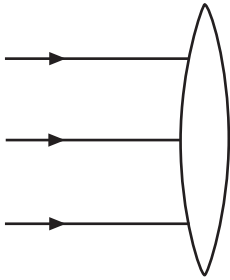

2

(b) A student can see clearly when looking at distant objects, but has to use spectacles when reading a book.

(i) What is this eye defect called?

1

(ii) What type of lens is used in the spectacles to correct this defect?

1

*Marks*

27. The statements below have been made about X-rays. Some of the statements are **true** and some are **false**.

- A X-rays can be used to detect broken bones
- B X-rays are invisible to the human eye
- C Heat is another name for X-rays
- D X-rays can be used to scan luggage at airports
- E Photographic film can detect X-rays
- F X-rays can damage living cells
- G X-rays travel at the speed of sound

Complete the table by entering the letter for each statement in the correct column.

The first letter has been entered for you.

<b>True</b>	<b>False</b>
A	

**3****[Turn over**

Marks

28. A spectator watches a golfer from a distance of 480 metres. He sees the club hitting the ball but notices a time delay before he hears the sound of the club hitting the ball.

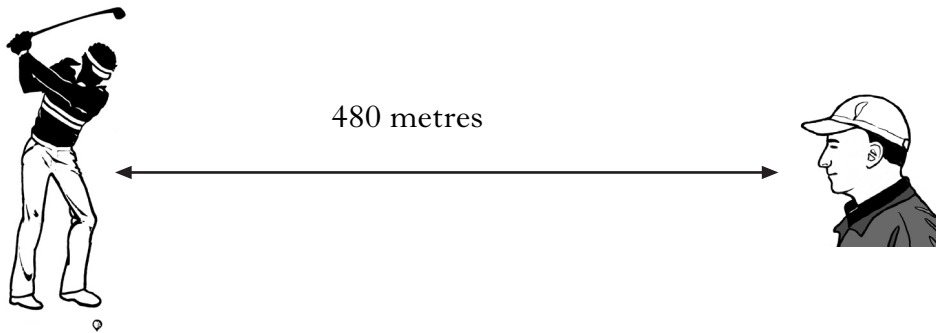

- (a) Explain why there is a time delay.

1

- (b) The sound takes 1.5 seconds to travel 480 metres from the golfer to the spectator. Use these figures to calculate the speed of sound.

2

- (c) The golfer plays a second shot using the same club but this time he wants the ball to travel a greater distance. State **two** things the golfer could change to make the ball travel further.

2

*Marks*

29. (a) In each of the sentences below, circle one word from the boxes to make the statements correct.

(i) Sound  pass through a vacuum.

1

(ii) Sound  pass through solids.

1

(b) Describe a method for measuring the speed of sound in air.

Your description should include:

The equipment you would require:

The measurements you would make:

How you would calculate the speed of sound:

3

**[Turn over**

Marks

30. A toy car is timed going round a track. The car takes 8 seconds to cover 4 laps of the track. One lap of the track is a distance of 3 metres.

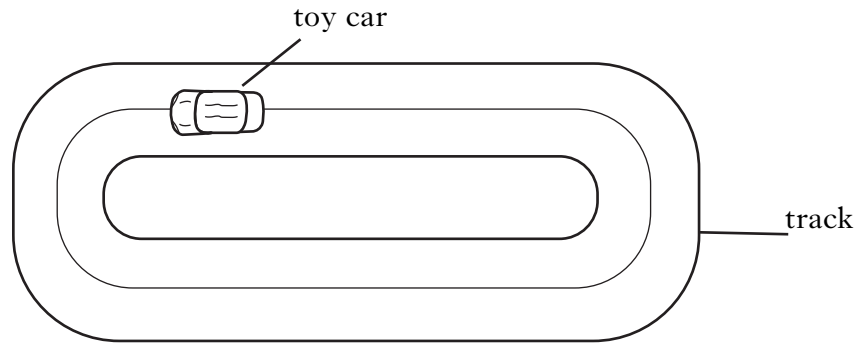

- (a) Calculate the average speed of the car on the track.

3

- (b) The original car is replaced by a more streamlined one. Explain the term **streamlined**.

1

Marks

31. Wind exerts a forward force on a yacht causing it to move in the direction shown.

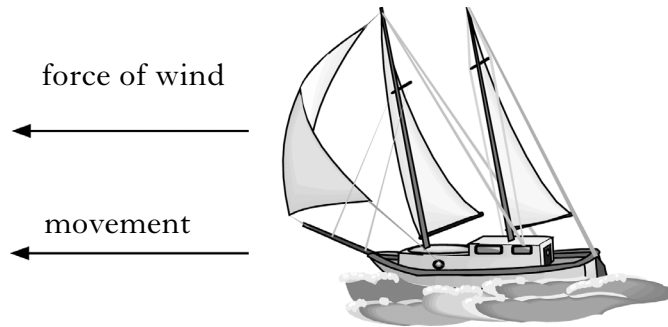

- (a) There is another force on the yacht acting in the opposite direction to the direction of movement. Name this force.

1

- (b) The yacht must be lifted out of the water for repairs.

A machine for lifting yachts can exert a maximum upwards force of 14 000 newtons. The yacht has a mass of 1500 kilograms.

- (i) Calculate the weight of the yacht.

2

- (ii) Will the machine be able to lift the yacht out of the water?

1

- (iii) Explain your answer.

1

Marks

32. (a) Complete the sentences using some of these words.

**keyboard****processor****monitor****program**

An input device for a computer is a

An output device for a computer is a

**1**

(b) The table below shows the cost of running electrical appliances during one day.

<i>Appliance</i>	<i>Power</i>	<i>Time used in hours</i>	<i>Electrical units used</i>	<i>Cost per unit</i>	<i>Total cost</i>
Electric heater	2	4	8	10 p	80 p
Dishwasher	3	1	3	10 p	30 p
Computer	0.2	6		10 p	

The *Electrical units used* can be calculated by  $Power \times Time\ used\ in\ hours$ .

(i) Calculate the *Electrical units used* by the computer.

**1**

Marks

**32. (b) (continued)**

(ii) Calculate the *Total cost* of running the computer.

**1**

(c) The dishwasher is an electronic system. Name the three parts of an electronic system.

**1**

**[Turn over**

Marks

33. Lights in a shop window are connected to an electronic system which switches them on when it becomes dark. The lights can also be switched on by a master switch.

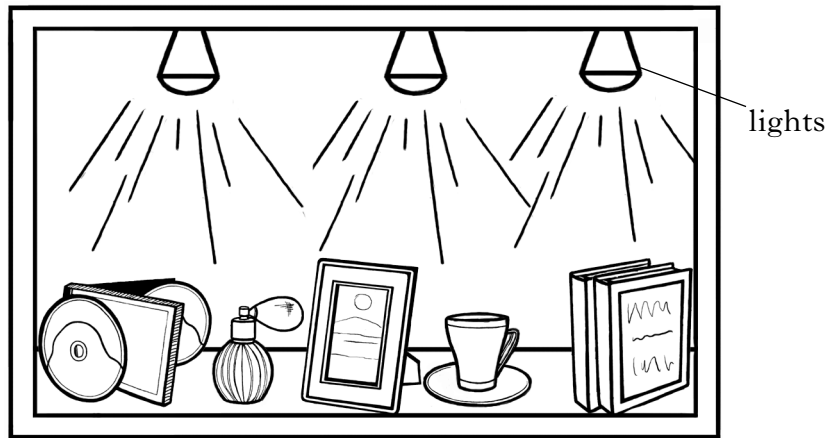

(a) A diagram for the electronic system is shown below.

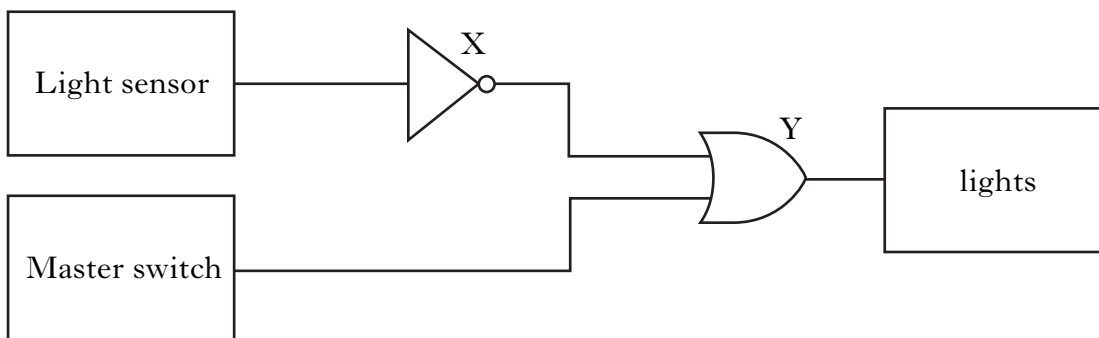

**Light sensor in darkness gives a logic 0.**  
**Light sensor in light gives a logic 1.**

- (i) Name logic gate X.

1

- (ii) Explain the function of logic gate X.

2

- (iii) Name logic gate Y.

1

Marks

**33. (continued)**

(b) The shop owner buys a new electronic system which requires both darkness and the master switch to be on to make the lights come on.

Complete the diagram below by drawing in the symbols for the logic gates required for the new system.

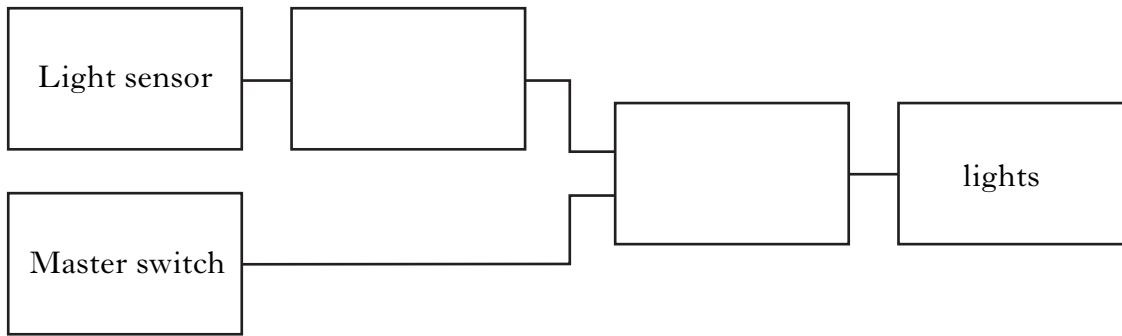

2

[END OF QUESTION PAPER]

*Marks*

**YOU MAY USE THE SPACE ON THIS PAGE TO REWRITE ANY ANSWER YOU HAVE DECIDED TO CHANGE IN THE MAIN PART OF THE ANSWER BOOKLET. TAKE CARE TO WRITE IN CAREFULLY THE APPROPRIATE QUESTION NUMBER.**