

X100/203

NATIONAL
QUALIFICATIONS
2009

THURSDAY, 21 MAY
2.05 PM – 3.35 PM

MATHEMATICS
INTERMEDIATE 2
Units 1, 2 and 3
Paper 2

Read carefully

- 1 **Calculators may be used in this paper.**
- 2 Full credit will be given only where the solution contains appropriate working.
- 3 Square-ruled paper is provided.



FORMULAE LIST

The roots of $ax^2 + bx + c = 0$ are $x = \frac{-b \pm \sqrt{(b^2 - 4ac)}}{2a}$

Sine rule: $\frac{a}{\sin A} = \frac{b}{\sin B} = \frac{c}{\sin C}$

Cosine rule: $a^2 = b^2 + c^2 - 2bc \cos A$ or $\cos A = \frac{b^2 + c^2 - a^2}{2bc}$

Area of a triangle: $\text{Area} = \frac{1}{2}ab \sin C$

Volume of a sphere: $\text{Volume} = \frac{4}{3}\pi r^3$

Volume of a cone: $\text{Volume} = \frac{1}{3}\pi r^2 h$

Volume of a cylinder: $\text{Volume} = \pi r^2 h$

Standard deviation: $s = \sqrt{\frac{\sum (x - \bar{x})^2}{n - 1}} = \sqrt{\frac{\sum x^2 - (\sum x)^2 / n}{n - 1}}$, where n is the sample size.

ALL questions should be attempted.

Marks

1. A new book “Intermediate 2 Maths is Fun” was published in 2006.
There were 3000 sales of the book during that year.
Sales rose by 11% in 2007 then fell by 10% in 2008.

Were the sales in 2008 more or less than the sales in 2006?

You must give a reason for your answer.

3

2. The heights, in centimetres, of seven netball players are given below.

173 176 168 166 170 180 171

For this sample, calculate:

(a) the mean;

1

(b) the standard deviation.

3

Show clearly all your working.

[Turn over

3. A company manufactures aluminium tubes.
The cross-section of one of the tubes is shown in the diagram below.

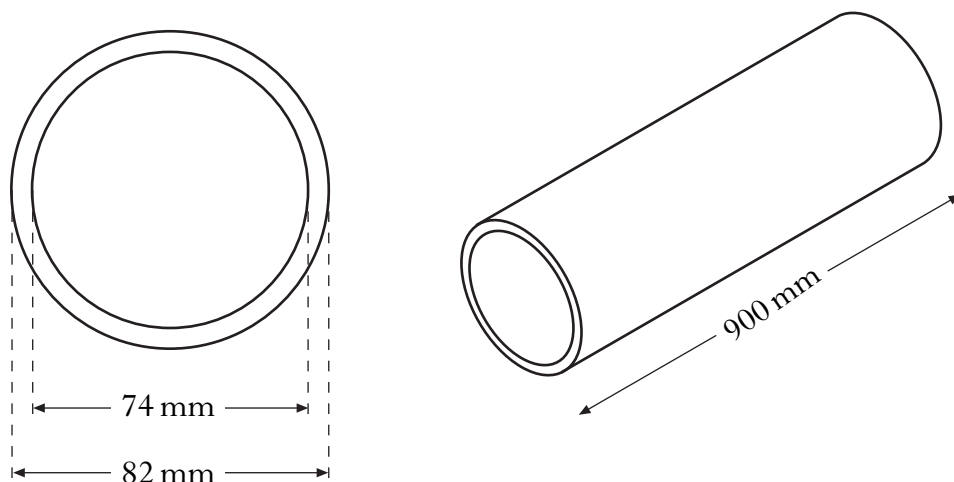

The inner diameter is 74 millimetres.

The outer diameter is 82 millimetres.

The tube is 900 millimetres long.

Calculate the volume of aluminium used to make the tube.

Give your answer correct to three significant figures.

5

4. There are 14 cars and 60 passengers on the morning crossing of the ferry from Wemyss Bay to Rothesay. The total takings are £344.30.

(a) Let x pounds be the cost for a car and y pounds be the cost for a passenger.

Write down an equation in x and y which satisfies the above condition.

1

(b) There are 21 cars and 40 passengers on the evening crossing of the ferry. The total takings are £368.95.

Write down a second equation in x and y which satisfies this condition.

1

(c) Find the cost for a car and the cost for a passenger on the ferry.

4

5. A pet shop manufactures protective dog collars. In the diagram below the shaded area represents one of these collars.

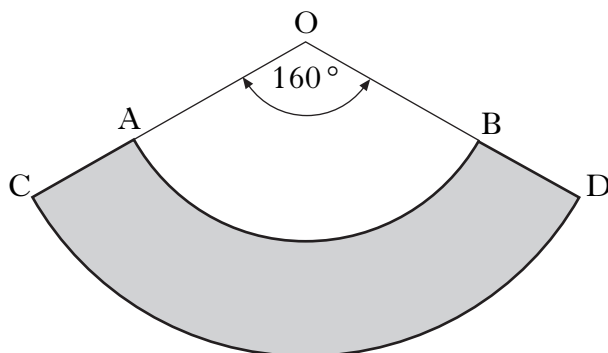

AB and CD are arcs of the circles with centres at O.
 The radius, OA, is 10 inches and the radius, OC, is 18 inches.
 Angle AOB is 160° .

Calculate the area of a collar.

4

6. The Bermuda triangle is an area in the Atlantic Ocean where many planes and ships have mysteriously disappeared. Its vertices are at Bermuda (B), Miami (M) and Puerto Rico (P).

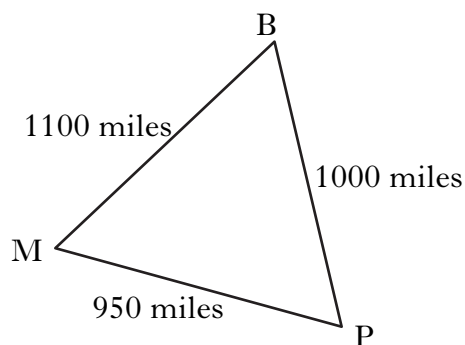
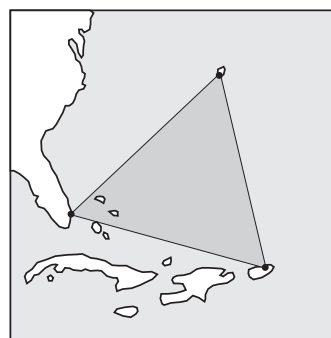

Calculate the size of angle BPM.

3

7. Solve the equation

$$x^2 + 5x + 3 = 0,$$

giving the roots correct to one decimal place.

4

[Turn over

8. Express

$$\frac{2}{x-1} + \frac{4}{x+2} \quad x \neq 1, x \neq -2$$

as a single fraction in its simplest form.

3

9. Change the subject of the formula

$$A = \frac{1}{2}h(a+b)$$

to h .

2

10. Solve the equation

$$7 \sin x^\circ + 1 = -5, \quad 0 \leq x \leq 360.$$

3

11. Express $\frac{12}{\sqrt{2}}$ with a rational denominator.

Give your answer in its simplest form.

2

12. Simplify

$$\frac{ab^6}{a^3b^2}$$

2

13. For reasons of safety, a building is supported by two wooden struts, represented by DB and DC in the diagram below.

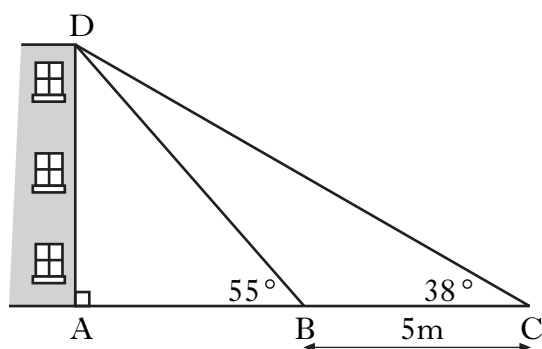

Angle ABD = 55° .

Angle BCD = 38° .

BC is 5 metres.

Calculate the height of the building represented by AD.

5

14. A railway goes through an underground tunnel.

The diagram below shows the cross-section of the tunnel. It consists of part of a circle with a horizontal base.

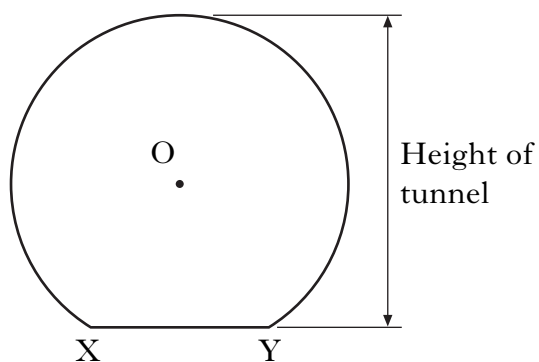
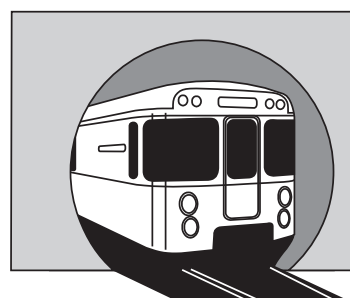

- The centre of the circle is O.
- XY is a chord of the circle.
- XY is 1.8 metres.
- The radius of the circle is 1.7 metres.

Find the height of the tunnel.

4

[END OF QUESTION PAPER]

[BLANK PAGE]