

X069/201

NATIONAL
QUALIFICATIONS
2009

TUESDAY, 26 MAY
1.00 PM – 3.00 PM

PHYSICS
INTERMEDIATE 2

Read Carefully

Reference may be made to the Physics Data Booklet

- 1 All questions should be attempted.

Section A (questions 1 to 20)

- 2 Check that the answer sheet is for Physics Intermediate 2 (Section A).
- 3 For this section of the examination you must use an **HB pencil** and, where necessary, an eraser.
- 4 Check that the answer sheet you have been given has **your name, date of birth, SCN** (Scottish Candidate Number) and **Centre Name** printed on it.
Do not change any of these details.
- 5 If any of this information is wrong, tell the Invigilator immediately.
- 6 If this information is correct, **print** your name and seat number in the boxes provided.
- 7 There is **only one correct** answer to each question.
- 8 Any rough working should be done on the question paper or the rough working sheet, **not** on your answer sheet.
- 9 At the end of the exam, put the **answer sheet for Section A inside the front cover of your answer book**.
- 10 Instructions as to how to record your answers to questions 1–20 are given on page three.

Section B (questions 21 to 29)

- 11 Answer the questions numbered 21 to 29 in the answer book provided.
- 12 **All answers must be written clearly and legibly in ink.**
- 13 Fill in the details on the front of the answer book.
- 14 Enter the question number clearly in the margin of the answer book beside each of your answers to questions 21 to 29.
- 15 Care should be taken to give an appropriate number of significant figures in the final answers to calculations.



DATA SHEET

Speed of light in materials

<i>Material</i>	<i>Speed in m/s</i>
Air	3.0×10^8
Carbon dioxide	3.0×10^8
Diamond	1.2×10^8
Glass	2.0×10^8
Glycerol	2.1×10^8
Water	2.3×10^8

Speed of sound in materials

<i>Material</i>	<i>Speed in m/s</i>
Aluminium	5200
Air	340
Bone	4100
Carbon dioxide	270
Glycerol	1900
Muscle	1600
Steel	5200
Tissue	1500
Water	1500

Gravitational field strengths

	<i>Gravitational field strength on the surface in N/kg</i>
Earth	10
Jupiter	26
Mars	4
Mercury	4
Moon	1.6
Neptune	12
Saturn	11
Sun	270
Venus	9

Specific heat capacity of materials

<i>Material</i>	<i>Specific heat capacity in J/kg °C</i>
Alcohol	2350
Aluminium	902
Copper	386
Glass	500
Ice	2100
Iron	480
Lead	128
Oil	2130
Water	4180

Specific latent heat of fusion of materials

<i>Material</i>	<i>Specific latent heat of fusion in J/kg</i>
Alcohol	0.99×10^5
Aluminium	3.95×10^5
Carbon dioxide	1.80×10^5
Copper	2.05×10^5
Iron	2.67×10^5
Lead	0.25×10^5
Water	3.34×10^5

Melting and boiling points of materials

<i>Material</i>	<i>Melting point in °C</i>	<i>Boiling point in °C</i>
Alcohol	-98	65
Aluminium	660	2470
Copper	1077	2567
Glycerol	18	290
Lead	328	1737
Iron	1537	2747

Specific latent heat of vaporisation of materials

<i>Material</i>	<i>Specific latent heat of vaporisation in J/kg</i>
Alcohol	11.2×10^5
Carbon dioxide	3.77×10^5
Glycerol	8.30×10^5
Turpentine	2.90×10^5
Water	22.6×10^5

Radiation weighting factors

<i>Type of radiation</i>	<i>Radiation weighting factor</i>
alpha	20
beta	1
fast neutrons	10
gamma	1
slow neutrons	3

SECTION A

For questions 1 to 20 in this section of the paper the answer to each question is either A, B, C, D or E. Decide what your answer is, then, using your pencil, put a horizontal line in the space provided—see the example below.

EXAMPLE

The energy unit measured by the electricity meter in your home is the

- A kilowatt-hour
- B ampere
- C watt
- D coulomb
- E volt.

The correct answer is **A**—kilowatt-hour. The answer **A** has been clearly marked in **pencil** with a horizontal line (see below).

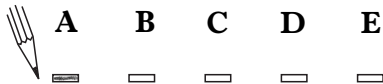

Changing an answer

If you decide to change your answer, carefully erase your first answer and, using your pencil, fill in the answer you want. The answer below has been changed to **E**.

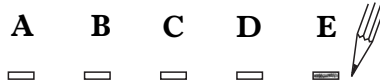

[Turn over

SECTION A

Answer questions 1–20 on the answer sheet.

1. Which of the following quantities requires both magnitude and direction?

- A Mass
- B Distance
- C Momentum
- D Speed
- E Time

2. A cross country runner travels 2.1 km North then 1.5 km East. The total time taken is 20 minutes.

The average speed of the runner is

- A 0.18 m/s
- B 2.2 m/s
- C 3.0 m/s
- D 130 m/s
- E 180 m/s.

3. The graph shows how the velocity of an object varies with time.

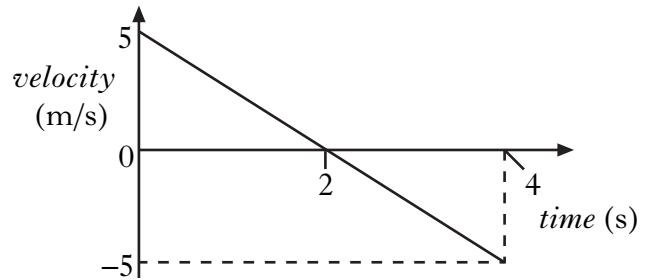

Which row in the table shows the displacement after 4 s and the acceleration of the object during the first 4 s?

	<i>Displacement</i> (m)	<i>Acceleration</i> (m/s ²)
A	10	-10
B	10	2.5
C	0	2.5
D	0	-10
E	0	-2.5

- 4 A ball is thrown horizontally from a cliff as shown.

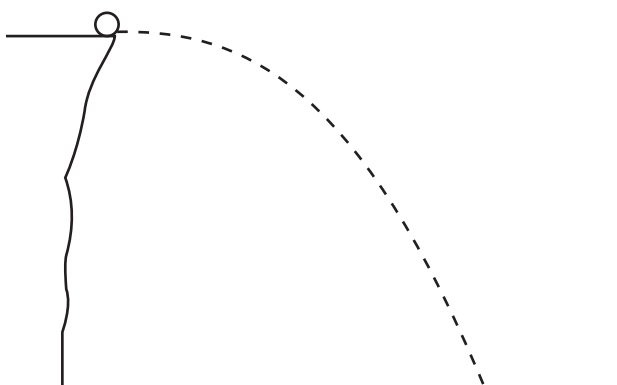

The effect of air resistance is negligible.

A student makes the following statements about the ball.

- I The vertical speed of the ball increases as it falls.
- II The vertical acceleration of the ball increases as it falls.
- III The vertical force on the ball increases as it falls.

Which of the statements is/are correct?

- A I only
- B II only
- C I and II only
- D II and III only
- E I, II and III

5. Which block has the largest resultant force acting on it?

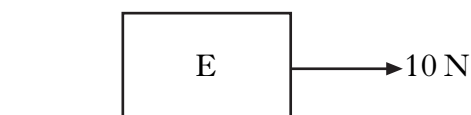
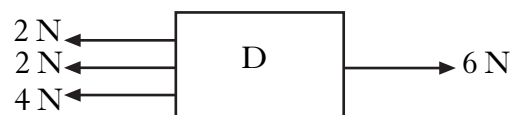
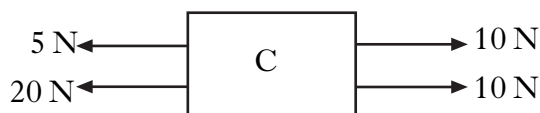
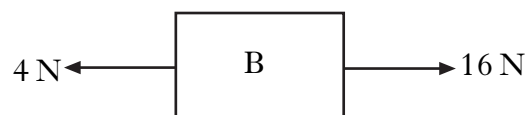
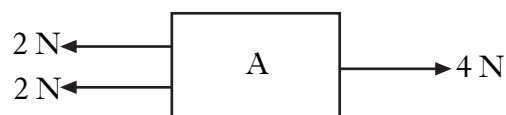

[Turn over

6. An arrow is fired from a bow as shown.

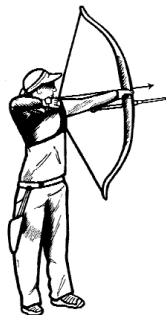

An archer pulls the string back a distance of 0.50 m. The string exerts an average force of 300 N on the arrow as it is fired. The mass of the arrow is 0.15 kg.

The maximum kinetic energy gained by the arrow is

- A 23 J
- B 150 J
- C 600 J
- D 2000 J
- E 6750 J.

7. A solid substance is placed in an insulated container and is heated at a constant rate. The graph shows how the temperature of the substance changes with time.

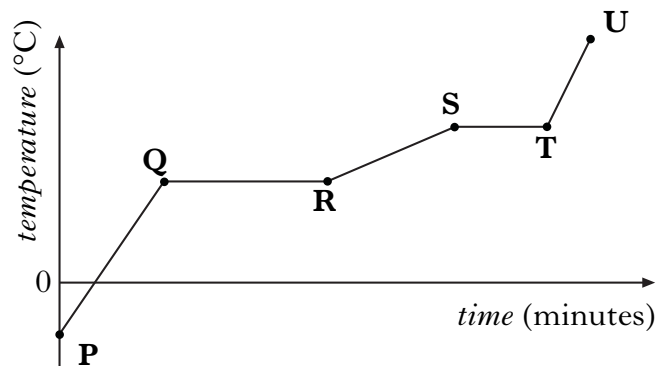

During the time interval QR, which of the following statements is/are correct?

- I There is a change in the state of the substance.
- II The substance changes state from a liquid to a gas.
- III Heat is absorbed by the substance.

- A I only
- B III only
- C I and II only
- D I and III only
- E I, II and III

8. A student writes the following statements about electrical conductors.

- I Only protons are free to move.
- II Only electrons are free to move.
- III Only negative charges are free to move.

Which of the statements is/are correct?

- A I only
- B II only
- C III only
- D I and II only
- E II and III only

9. A charge of 15 C passes through a resistor in 12 s. The potential difference across the resistor is 6 V.

The power developed by the resistor is

- A 4.8 W
- B 7.5 W
- C 9.4 W
- D 30 W
- E 1080 W.

10. A circuit is set up as shown.

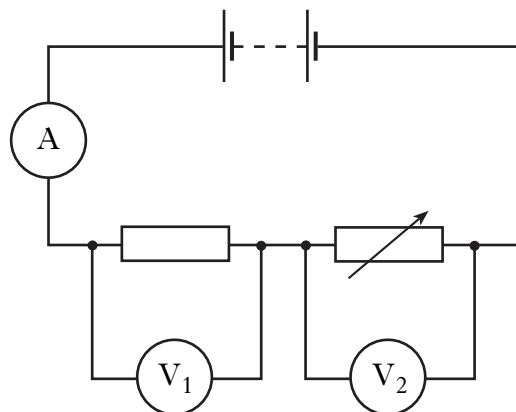

The resistance of the variable resistor is increased.

Which row in the table shows the effect on the readings on the ammeter and voltmeters?

	<i>Reading on ammeter</i>	<i>Reading on voltmeter V₁</i>	<i>Reading on voltmeter V₂</i>
A	decreases	decreases	decreases
B	increases	unchanged	increases
C	decreases	increases	decreases
D	increases	unchanged	decreases
E	decreases	decreases	increases

[Turn over

11. A circuit is set up as shown.

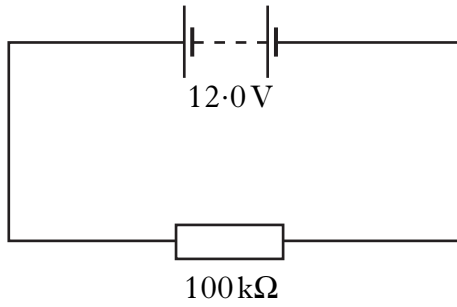

The power supplied to the resistor is

- A $1.20 \times 10^{-4} \text{ W}$
- B $1.44 \times 10^{-3} \text{ W}$
- C 1.44 W
- D 694 W
- E $1.20 \times 10^6 \text{ W}$

12. Which of the following devices transforms light energy into electrical energy?

- A LED
- B Thermocouple
- C Microphone
- D Solar cell
- E Transistor

13. Which of the following is the correct symbol for an n-channel enhancement MOSFET?

- A
- B
- C
- D
- E

14. Which of the following is an example of a longitudinal wave?
- A Light wave
 - B Infra-red wave
 - C Radio wave
 - D Sound wave
 - E Water wave

15. The diagram shows a list of the members of the electromagnetic spectrum in order of increasing wavelength.

gamma rays	P	ultraviolet	Q	infrared	R	TV and Radio
------------	----------	-------------	----------	----------	----------	--------------

Which row in the table shows the radiation represented by the letters **P**, **Q** and **R**?

	P	Q	R
A	microwaves	visible light	x-rays
B	visible light	microwaves	x-rays
C	x-rays	visible light	microwaves
D	visible light	x-rays	microwaves
E	x-rays	microwaves	visible light

16. The diagram shows what happens to a ray of light when it strikes a glass block.

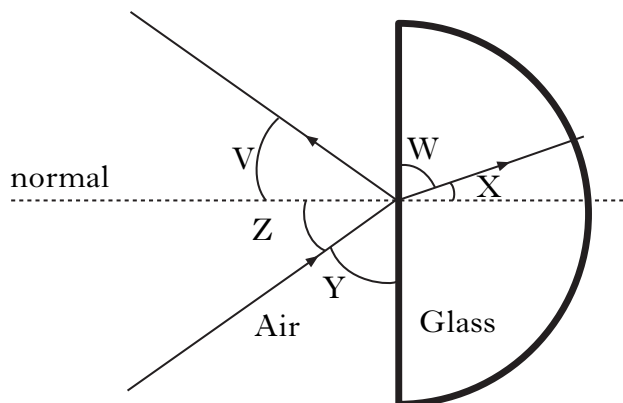

Which row in the table identifies the angle of incidence and the angle of refraction?

	<i>Angle of Incidence</i>	<i>Angle of Refraction</i>
A	V	W
B	Y	W
C	Y	X
D	Z	W
E	Z	X

[Turn over

17. The diagram below shows a simple model of an atom.

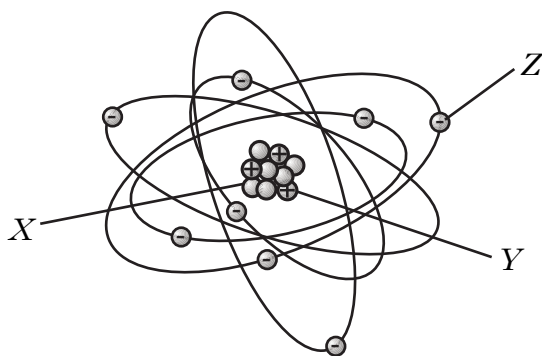

Which row in the table identifies particles X, Y and Z?

	X	Y	Z
A	electron	proton	neutron
B	proton	neutron	electron
C	neutron	electron	proton
D	electron	neutron	proton
E	neutron	proton	electron

18. A student makes the following statements about ionising radiations.

I Ionisation occurs when an atom loses an electron.

II Gamma radiation produces greater ionisation (density) than alpha particles.

III An alpha particle consists of 2 protons, 2 neutrons and 2 electrons.

Which of the statements is/are correct?

- A I only
 B II only
 C I and II only
 D II and III only
 E I, II and III

19. A sample of tissue has a mass of 0.05 kg.

The tissue is exposed to radiation and absorbs 0.1 J of energy in 2 minutes.

The absorbed dose is

- A 0.005 Gy
 B 0.1 Gy
 C 0.5 Gy
 D 2 Gy
 E 6 Gy.

20. During fission, a neutron splits a uranium nucleus into two nuclei, X and Y, as shown below.

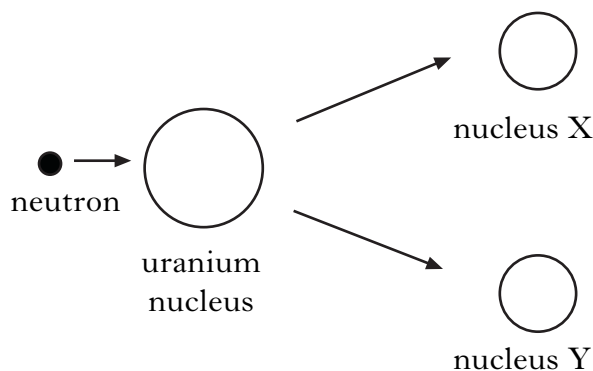

For a chain reaction to occur which of the following **must** also be released?

- A Protons
 B Electrons
 C Neutrons
 D Alpha particles
 E Gamma radiation

Candidates are reminded that the answer sheet for Section A MUST be placed INSIDE the front cover of the answer book.

SECTION B

Marks

Write your answers to questions 21–29 in the answer book.

All answers must be written clearly and legibly in ink.

21. A ski lift with a gondola of mass 2000 kg travels to a height of 540 m from the base station to a station at the top of the mountain.

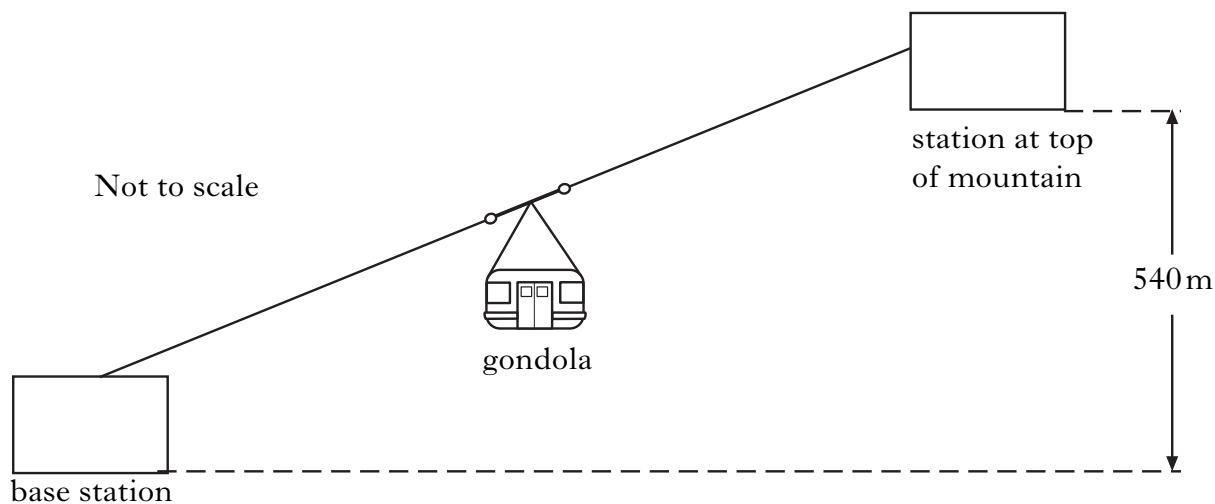

- (a) Calculate the gain in gravitational potential energy of the gondola. 2
- (b) During the journey, the kinetic energy of the gondola is 64 000 J.
Calculate the speed of the gondola. 2
- (c) The ski lift requires a motor which operates at 380 V to take the gondola up the mountain. The maximum power produced is 45.6 kW.
- (i) Calculate the maximum current in the motor. 2
- (ii) Calculate the electrical energy used by the motor when it has been operating at its maximum power for a total time of 1 hour. 2
- (8)**

[Turn over

22. A child sledges down a hill.

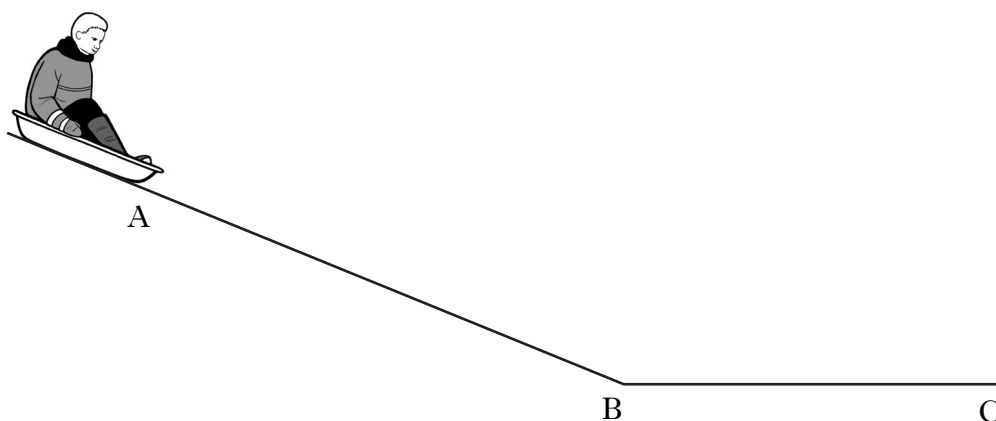

The sledge and child are released from rest at point A. They reach a speed of 3 m/s at point B.

(a) The sledge and child take 5 s to reach point B.

Calculate the acceleration.

2

(b) The sledge and child have a combined mass of 40 kg.

Calculate the unbalanced force acting on them.

2

(c) After the sledge and child pass point B, they slow down, coming to a halt at point C.

Explain this motion in terms of forces.

2

(6)

23. The following apparatus is used to determine the speed of a pellet as it leaves an air rifle. The air rifle fires a pellet into the plasticine, causing the vehicle to move.

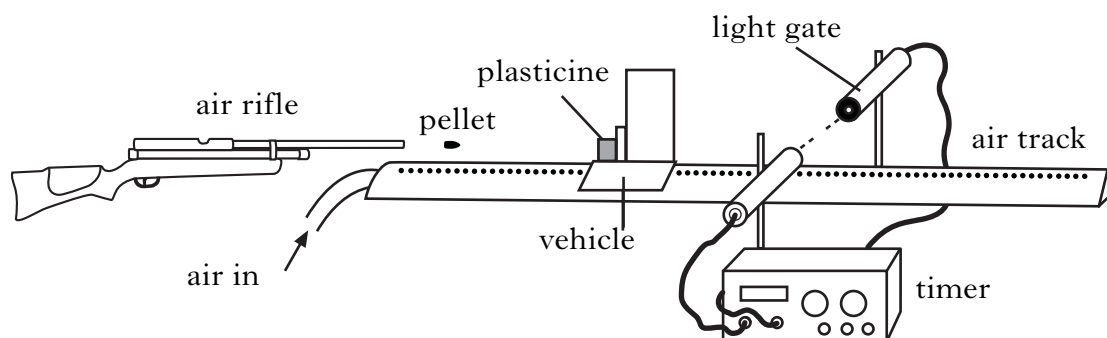

- (a) Describe how the apparatus is used to determine the speed of the vehicle.

Your description must include:

- the measurements made
- any necessary calculations.

2

- (b) The speed of the vehicle is calculated as 0.35 m/s after impact.

The mass of the pellet is 5.0×10^{-4} kg. The mass of the vehicle and plasticine before impact is 0.30 kg.

- (i) Show that the momentum of the pellet **before** impact with the plasticine is 0.105 kg m/s.

1

- (ii) Hence, calculate the velocity of the pellet **before** impact with the plasticine.

1

- (c) At a firing range a pellet is fired horizontally at a target 40 m away. It takes 0.20 s to reach the target.

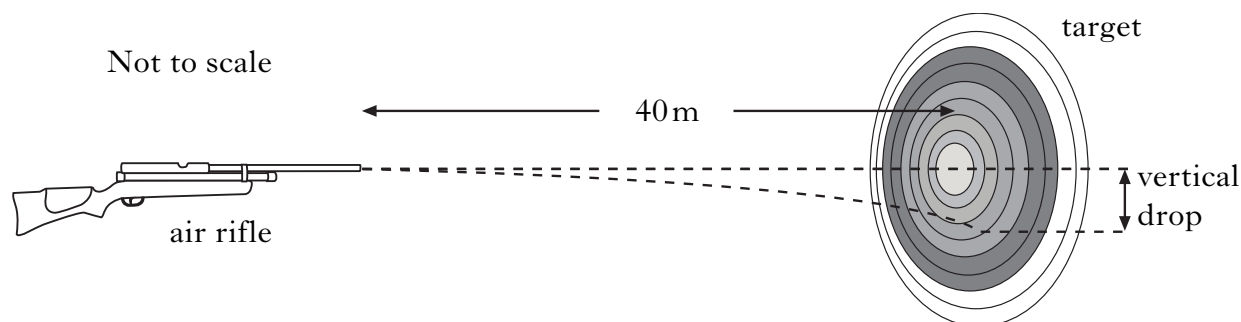

- (i) Calculate the **vertical** velocity of the pellet on reaching the target.

2

- (ii) Calculate the vertical drop.

2

(8)

[Turn over

24. A fridge/freezer has water and ice dispensers as shown.

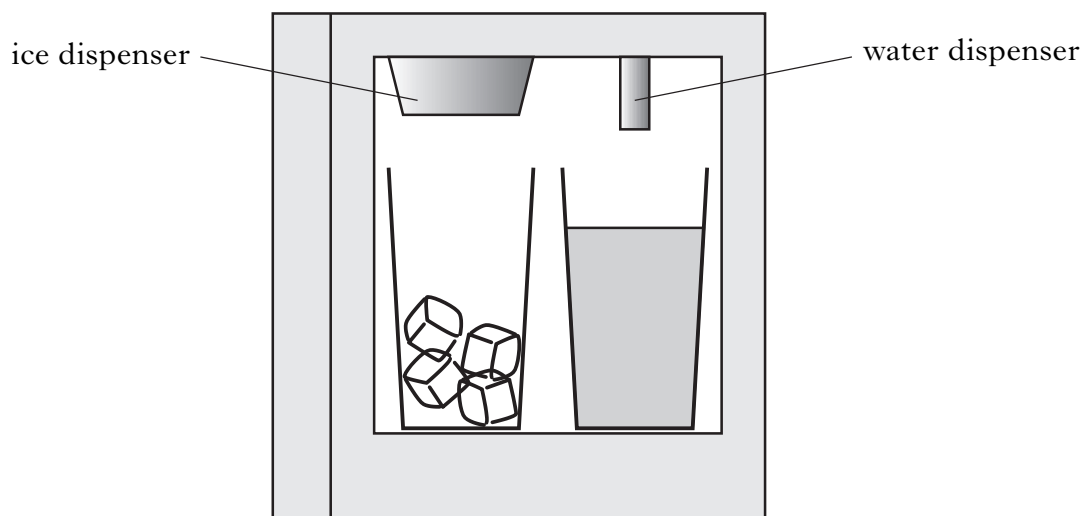

- (a) Water of mass 0.1 kg flows into the freezer at 15°C and is cooled to 0°C . Calculate the energy removed when the water cools. 2
- (b) Calculate how much energy is released when 0.1 kg of water at 0°C changes to 0.1 kg of ice at 0°C . 2
- (c) The fridge/freezer system removes heat energy at a rate of 125 J/s .
- (i) Calculate the minimum time taken to produce 0.1 kg of ice from 0.1 kg of water at 15°C . 3
- (ii) Explain why the actual time taken to make the ice will be longer than the value calculated in part (i). 2
- (9)**

25. A student sets up the following circuit to investigate the resistance of resistor R.

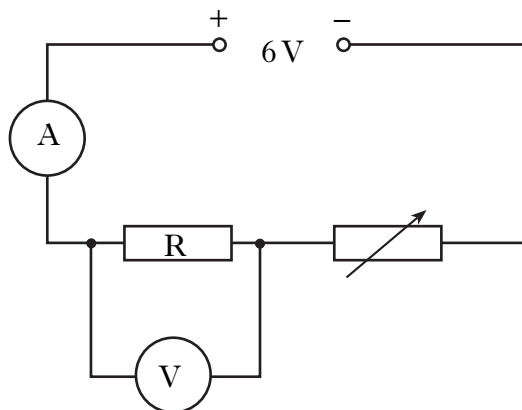

The variable resistor is adjusted and the voltmeter and ammeter readings are noted. The following graph is obtained from the experimental results.

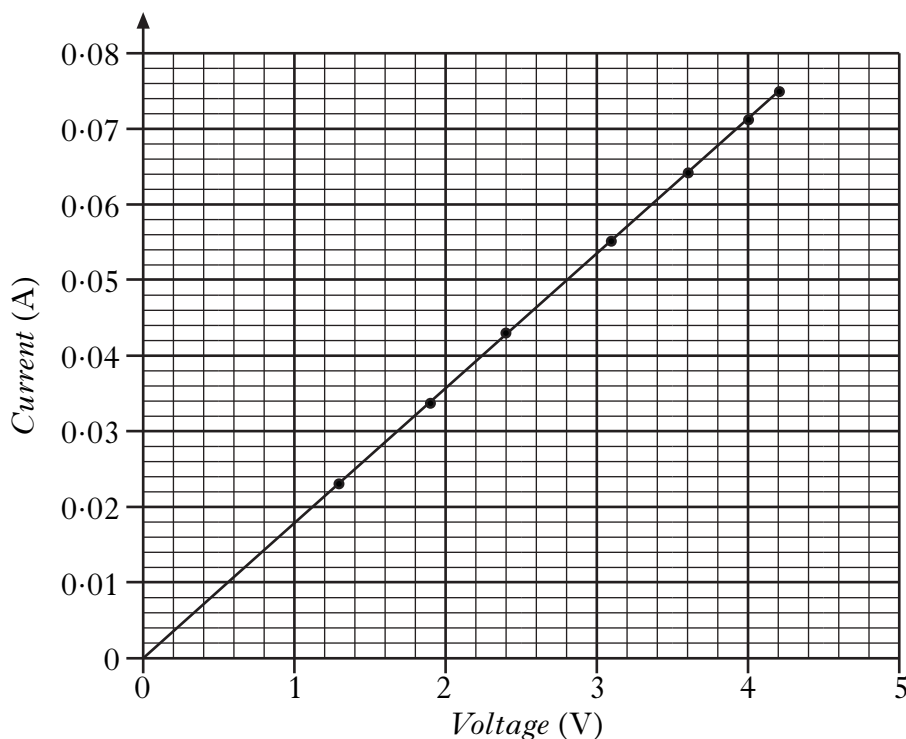

(a) (i) Calculate the value of the resistor R when the reading on the voltmeter is 4.2 V. 3

(ii) Using information from the graph, state whether the resistance of the resistor R, **increases**, **stays the same** or **decreases** as the voltage increases.

Justify your answer. 2

(b) The student is given a task to combine two resistors from a pack containing one each of 33 Ω, 56 Ω, 82 Ω, 150 Ω, 270 Ω, 390 Ω.

Show by calculation which **two** resistors should be used to give:

(i) the largest combined resistance; 2

(ii) the smallest combined resistance. 2

(9)

26. An MP3 player is charged from the mains supply of 230 V using a transformer, which has an output voltage of 5 V and an output current of 1 A.

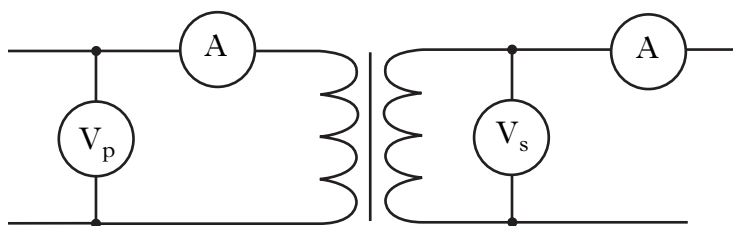

circuit diagram of transformer



MP3 Charger

- (a) Calculate the current in the primary circuit. 2
- (b) The MP3 player is then put on a docking station with external speakers.



- (i) Calculate the resistance of a 10 W speaker when the voltage across it is 9 V. 2
- (ii) Calculate the gain of the amplifier in the docking station when the input voltage is 1.5 V. 2
- (c) The input power to the amplifier is 25 W. The output power is 20 W. Calculate the efficiency of the amplifier. 2

(8)

27. A student is short sighted.

- (a) (i) What does the term “short sighted” mean? 1
- (ii) What type of lens is required to correct this eye defect? 1
- (iii) The focal length of the lens needed to correct the student’s short sight is 180 mm. Calculate the power of this lens. 2
- (b) In the eye, refraction of light occurs at both the cornea and the lens. Some eye defects can be corrected using a laser. Light from the laser is used to change the shape of the cornea.

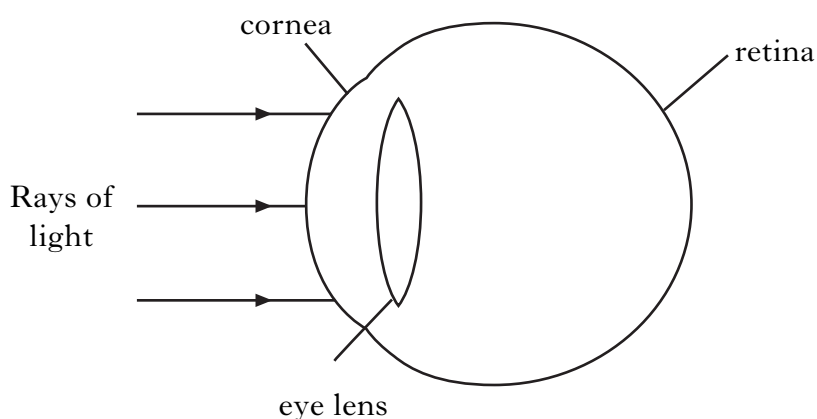

- (i) State what is meant by refraction of light. 1
- (ii) The laser emits light of wavelength 7×10^{-7} m. Calculate the frequency of the light. 2
- (c) Lasers can be used in optical fibres for medical purposes.
- (i) Copy and complete the path of the laser light along the optical fibre. 2

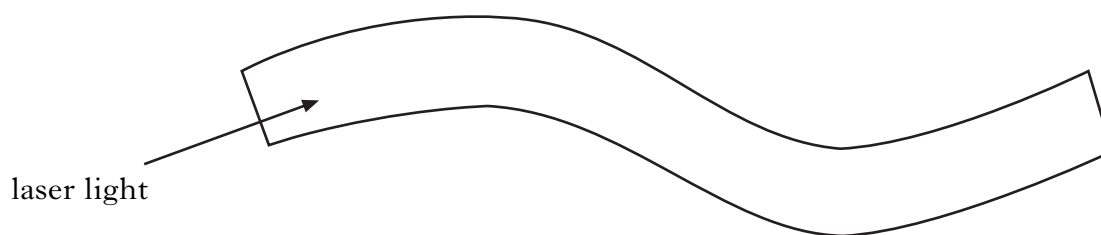

- (ii) Name the effect when the laser light hits the inside surface of the fibre. 1
- (10)**

[Turn over

28. Parking sensors are fitted to the rear bumper of some cars. A buzzer emits audible beeps, which become more frequent as the car moves closer to an object.

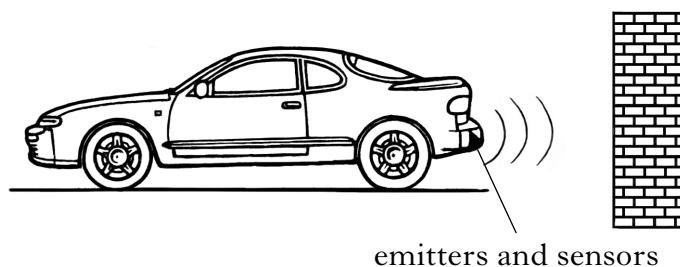

Ultrasonic pulses are emitted from the rear of the car. Objects behind the car reflect the pulses, which are detected by sensors. Ultrasonic pulses travel at the speed of sound.

- (a) The time between these pulses being sent and received is 2×10^{-3} s.
Calculate the distance between the object and the rear of the car. 3
- (b) At a certain distance, the buzzer beeps every 0.125 s.
Calculate the frequency of the beeps. 2
- (c) The sensor operates at a voltage of 12 V and has a current range of 20–200 mA.
Calculate the maximum power rating of the sensor. 3
- (d) An LED system can be added so that it flashes at the same frequency as the beeps from the buzzer. The LED circuit is shown below.

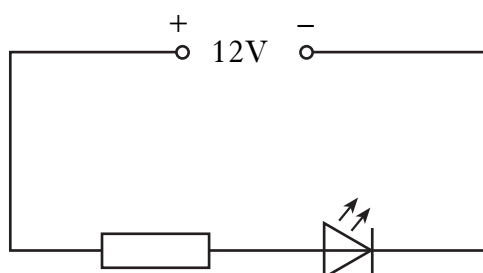

- (i) A resistor is connected in series with the LED.
State the purpose of the resistor. 1
- (ii) When lit, the LED has a voltage of 3.5 V across it and a current of 200 mA.
Calculate the value of the resistor. 3
- (12)**

29. A radioactivity kit includes three radioactive sources each made up as shown.

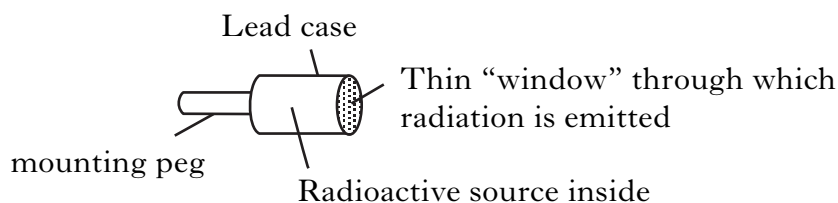

Information about these sources is given in the table below.

	<i>Radiation Emitted</i>	<i>Radioactive Element</i>
Source 1	Alpha	Americium 241
Source 2	Beta	Strontium 90
Source 3	Gamma + Beta	Cobalt 60

- (a) (i) Describe an experiment to show which is the alpha emitting source.
Your description must include:
- equipment used
 - measurements taken
 - an explanation of the results. 3
- (ii) The radioactive material in Source 3 emits both beta and gamma radiations. Describe how the window of the casing could be modified so that the beta radiation is stopped. 1
- (b) Strontium 90 has a half life of 28 years. Calculate how many years it takes for the activity to decrease to 1/16th of its original value. 2
- (c) (i) A technician working with Source 1 receives an absorbed dose of 20 μGy of alpha particles. Calculate the total equivalent dose received by the technician. 2
- (ii) Describe two ways in which the technician could reduce his absorbed dose. 2
- (10)**

[END OF QUESTION PAPER]

[BLANK PAGE]