

FOR OFFICIAL USE

--	--	--	--	--	--

F

KU RE

--	--

Total Marks

2500/401

NATIONAL
QUALIFICATIONS
2007

THURSDAY, 3 MAY
9.00 AM – 9.20 AM

MATHEMATICS
STANDARD GRADE
Foundation Level
Paper 1
Non-calculator

Fill in these boxes and read what is printed below.

Full name of centre

Town

Forename(s)

Surname

Date of birth

Day Month Year

--	--	--	--	--	--	--	--

Scottish candidate number

--	--	--	--	--	--	--	--	--	--

Number of seat

- You may NOT use a calculator.**
- Answer as many questions as you can.
- Write your working and answers in the spaces provided. Additional space is provided at the end of this question-answer book for use if required. If you use this space, write clearly the number of the question involved.
- Full credit will be given only where the solution contains appropriate working.
- Before leaving the examination room you must give this book to the invigilator. If you do not, you may lose all the marks for this paper.



Marks

KU	RE
1	
1	
2	

1. Work out the answers to the following.

(a) $1375 + 462$

WORKING

ANSWER

(b) 5.23×4

WORKING

ANSWER

(c) $\frac{1}{8}$ of 120 metres

WORKING

ANSWER

metres

2.



Fred bought a bicycle in this sale.

The marked price was £150.

How much money was taken off the marked price?

WORKING

ANSWER

£

2



Marks

	KU	RE
1		
1		

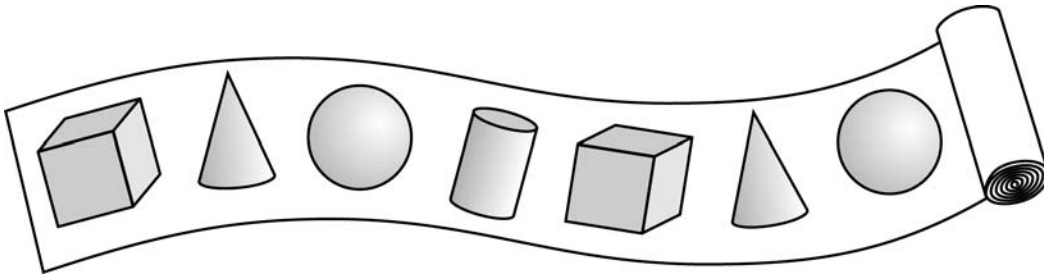
4. When George decorates his son's bedroom, he uses a wallpaper border.

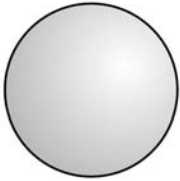

(a) Tick (✓) the **next** shape George will see as he continues to unroll the border.

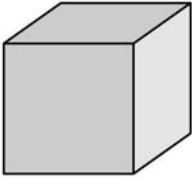
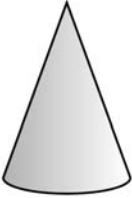
(b) Write down the mathematical name of the shape you have ticked.

ANSWER	
--------	--

8. Rebecca is on a submarine looking at the radar screen.

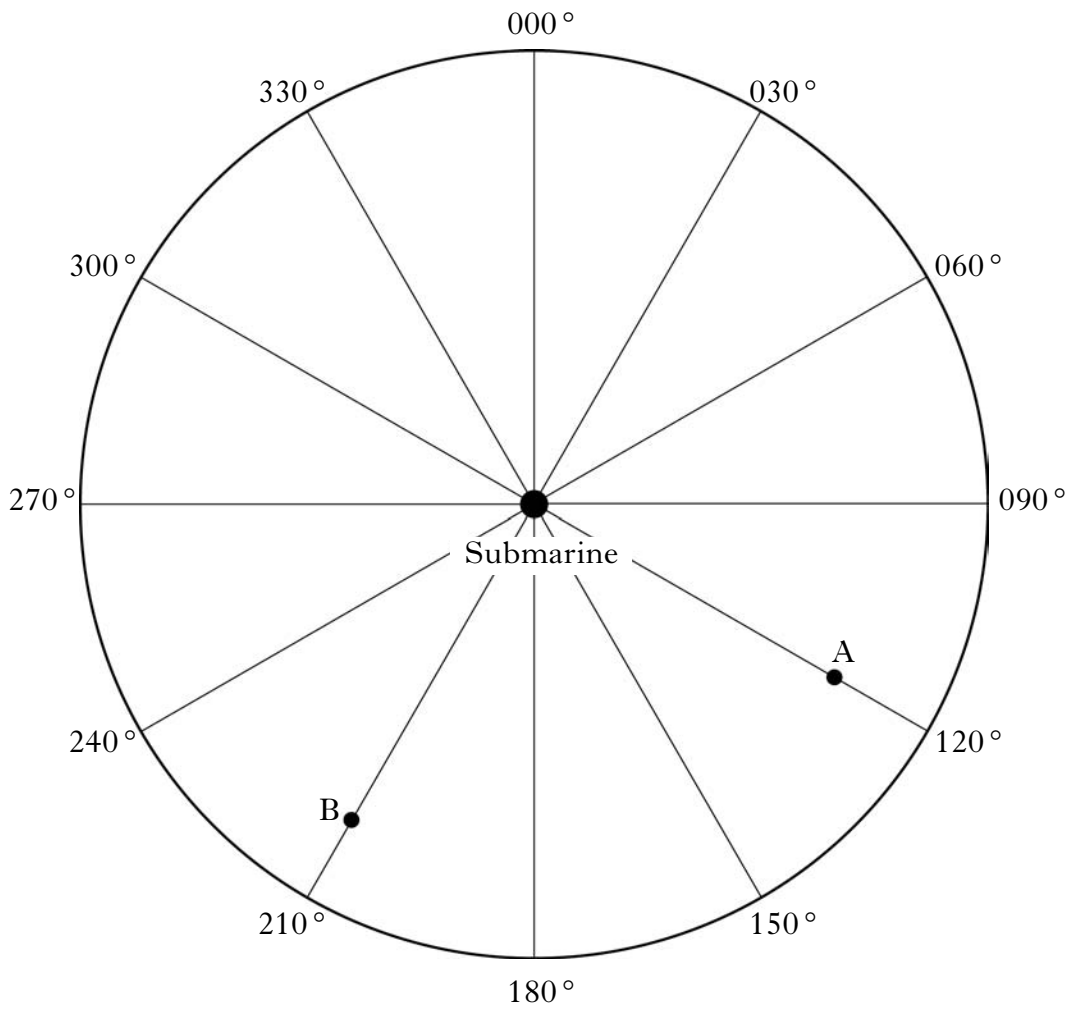

A and B show the positions of two ships.

Ship A is on a bearing of 120° from the submarine.

Write down the bearing of ship B from the submarine.

ANSWER	<input type="text"/>	°
--------	----------------------	---

1

[END OF QUESTION PAPER]

ADDITIONAL SPACE FOR ANSWERS

[BLANK PAGE]