

FOR OFFICIAL USE



National
Qualifications
2023

Mark

X813/76/01

**Chemistry
Paper 2**

FRIDAY, 12 MAY

10:10 AM – 12:30 PM



* X 8 1 3 7 6 0 1 *

Fill in these boxes and read what is printed below.

Full name of centre

Town

Forename(s)

Surname

Number of seat

Date of birth

Day

Month

Year

Scottish candidate number

Total marks — 95

Attempt ALL questions.

You may use a calculator.

You may refer to the Chemistry Data Booklet for Higher and Advanced Higher.

Write your answers clearly in the spaces provided in this booklet. Additional space for answers and rough work is provided at the end of this booklet. If you use this space you must clearly identify the question number you are attempting. Any rough work must be written in this booklet. Score through your rough work when you have written your final copy.

Use **blue** or **black** ink.

Before leaving the examination room you must give this booklet to the Invigilator; if you do not, you may lose all the marks for this paper.



* X 8 1 3 7 6 0 1 0 1 *

Total marks — 95
Attempt ALL questions

1. Elements are arranged in the periodic table in order of increasing atomic number. Many physical and chemical properties of the elements show periodic trends.

(a) First ionisation energy is a property that has a periodic trend.

The diagram shows part of a graph of first ionisation energy against atomic number for some elements in the periodic table.

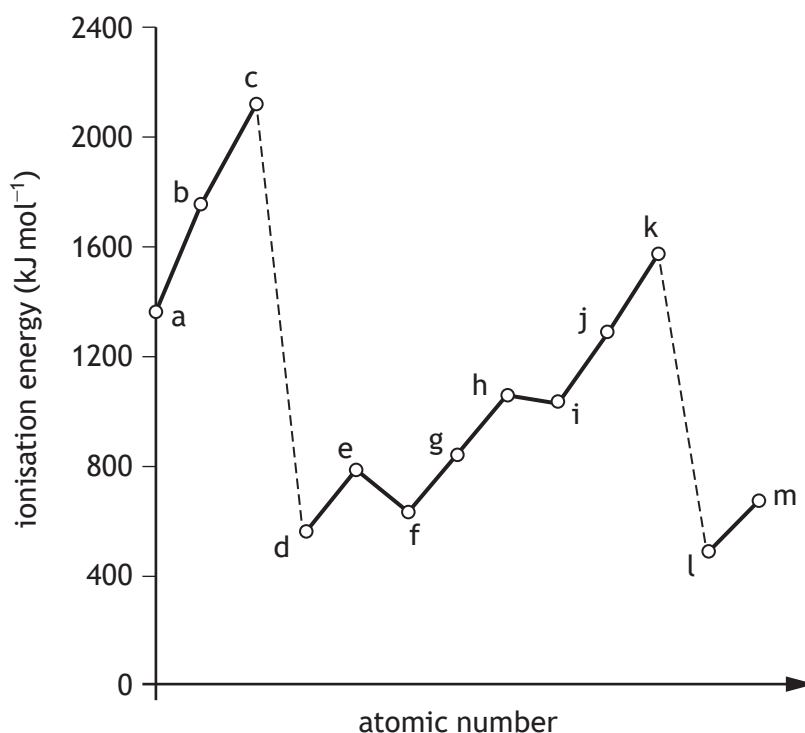

(i) Explain why there is an increase in first ionisation energy from elements d to k in the diagram.

1

(ii) State an element from a to m in the diagram that represents an element from group 7.

1



1. (a) (continued)

(iii) The table shows four ionisation energies of sodium.

Ionisation energy (kJ mol^{-1})			
First	Second	Third	Fourth
496	4562	6910	9543

(A) Explain **fully** the large increase between the first and second ionisation energies of sodium.

2

(B) Use the information in the table to determine the enthalpy change, in kJ mol^{-1} , for the following reaction.

1



[Turn over



1. (continued)

(b) Electronegativity is another property that has a periodic trend.

(i) State what is meant by the term electronegativity.

1

(ii) Explain **fully** why electronegativity decreases going down a group.

2

(iii) Suggest which of the group 2 elements is the best reducing agent.

1



* X 8 1 3 7 6 0 1 0 4 *

2. Hydrides are compounds containing hydrogen and one other element.

MARKS
DO NOT
WRITE IN
THIS
MARGIN

(a) The graph shows the boiling points of group 4 and group 5 hydrides.

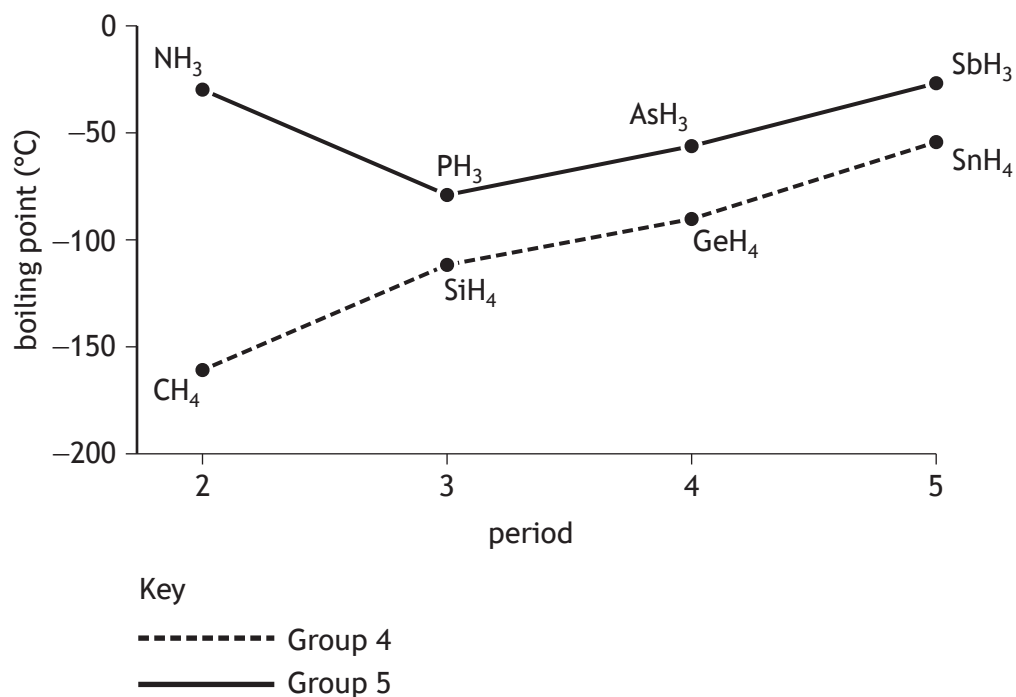

(i) Explain **fully** why the boiling points of the group 4 hydrides increase going down the group.

In your answer you should refer to the intermolecular forces involved.

3

(ii) Name the type of intermolecular force that is responsible for the anomalous boiling point of ammonia, NH₃.

1

[Turn over



2. (continued)

- (b) (i) Silicon hydride, SiH_4 , can be formed by reacting silicon with hydrogen.

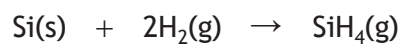

Calculate the enthalpy change, in kJ mol^{-1} , for this reaction using the following information.



2



2. (b) (continued)

- (ii) One method of preparing silicon hydride involves reacting magnesium silicide, Mg_2Si , with hydrochloric acid, HCl.

15.32 g of magnesium silicide was reacted with excess hydrochloric acid.
2.56 g of silicon hydride was produced.

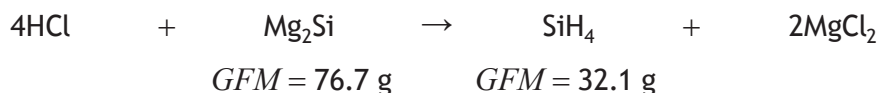

Calculate the percentage yield of silicon hydride.

2

- (iii) The table shows the melting points of silicon hydride, SiH_4 , and silicon oxide, SiO_2 .

	Melting point (°C)
SiH_4	-185
SiO_2	1710

Explain **fully** why silicon oxide has a much higher melting point than silicon hydride.

3

[Turn over



3. Cheese is a complex substance containing a wide variety of chemicals.

(a) The structure of a fat found in cheese is shown below.

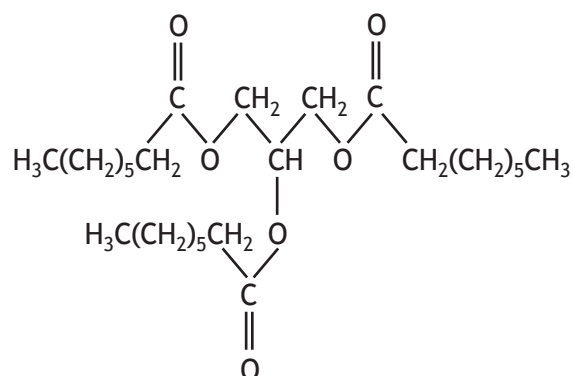

(i) (A) The alcohol needed to form fat molecules is glycerol.

State the systematic name for glycerol.

1

(B) Name the type of reaction used to form fat molecules from fatty acids and glycerol.

1



3. (a) (continued)

(ii) Fatty acid **W** reacts as shown.

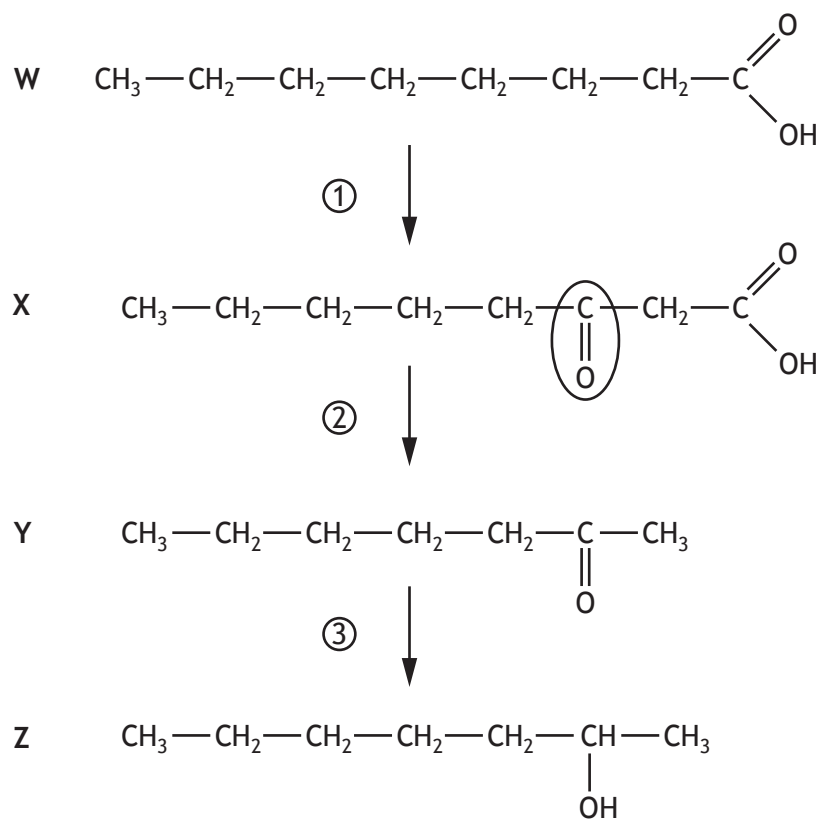

- (A) Identify the functional group circled in molecule **X**. 1
- (B) Name molecule **Y**. 1
- (C) Identify the type of reaction used to convert molecule **Y** into molecule **Z**. 1
- (D) State which of the reactions, $\textcircled{1}$, $\textcircled{2}$ or $\textcircled{3}$, results in an increase in the oxygen to hydrogen ratio. 1

[Turn over



3. (a) (continued)

- (iii) Fatty acids can be converted into hydroxycarboxylic acids.
An example of a hydroxycarboxylic acid is shown.

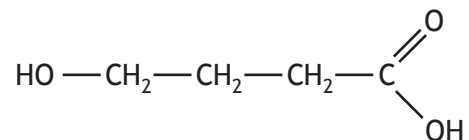

The two functional groups in a hydroxycarboxylic acid react together to form a cyclic ester.

An example of a cyclic ester is shown.

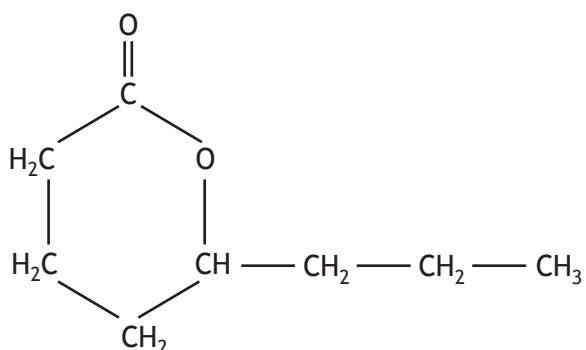

Draw a structural formula for the hydroxycarboxylic acid that can be used to produce this cyclic ester.

1



3. (a) (continued)

- (iv) The flavour of cheese changes over time as the concentrations of flavour molecules change.

Gas chromatography can be used to analyse the concentrations of flavour molecules.

(A) Chromatograms for two samples of cheese are shown below.

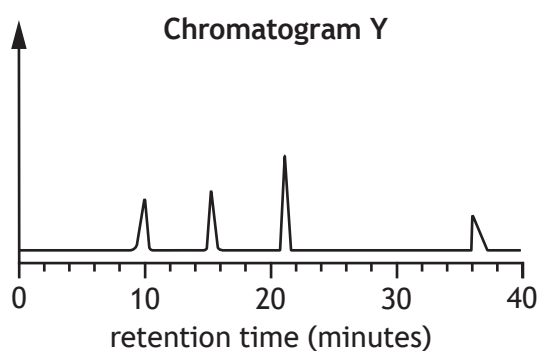
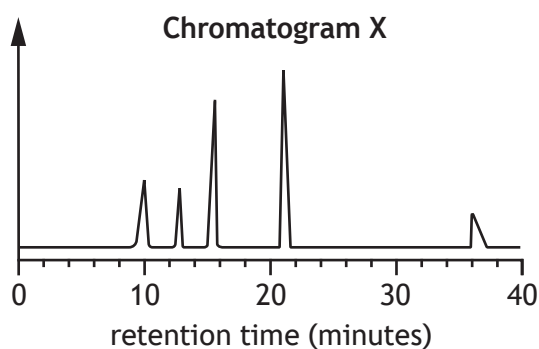

Determine the retention time, in minutes, of the peak in Chromatogram X that is missing in Chromatogram Y.

1

[Turn over

3. (a) (iv) (continued)

- (B) The following chromatogram was obtained from another sample of cheese. The concentration of a flavour molecule in cheese can be determined by calculating the area under the peak that corresponds to that molecule.

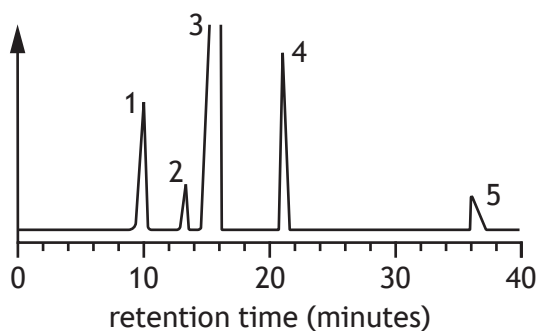

The concentration of flavour molecule 3 cannot be determined from this chromatogram.

Suggest what would need to be done to the sample to allow the concentration of flavour molecule 3 to be determined.

1

3. (b) (continued)

(iii) When cheese is heated, the proteins change shape.

State the term used to describe this process.

1

(c) Processed cheese is made from cheese, soluble milk proteins, water and an emulsifier.

State the function of an emulsifier.

1

(d) A compound added to cheese as a mould inhibitor has the formula $\text{Ca}^{2+}(\text{CH}_3\text{CH}_2\text{COO}^-)_2$.

Name this compound.

1



4. Volumetric analysis involves using a standard solution in a reaction with a well-defined end point to determine the concentration of another substance. Correct use of the appropriate apparatus and solutions is essential to ensure accurate determination of concentration by titration.

Using your knowledge of chemistry, describe the experimental procedures, including equipment, used to accurately determine the concentration of a substance by volumetric analysis.

3

[Turn over



* X 8 1 3 7 6 0 1 1 5 *

5. Gin is made by flavouring a mixture of ethanol and water with plant extracts.

- (a) (i) The mixture of ethanol and water is made by fermentation followed by distillation.

In fermentation, enzymes in yeast convert glucose, $C_6H_{12}O_6$, into ethanol and carbon dioxide.

The equation for fermentation is shown.

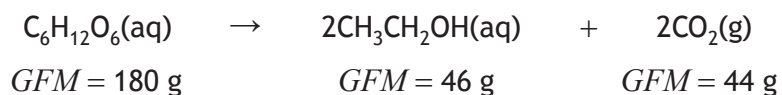

- (A) A 50.0 cm^3 sample of glucose solution contained 5.79 g of glucose.

Calculate the volume, in litres, of carbon dioxide gas that would be produced if 16 litres of this glucose solution was fermented.

3

Take the volume of 1 mole of carbon dioxide gas to be 24 litres.

- (B) Calculate the atom economy for the production of ethanol.

2



5. (a) (continued)

- (ii) The percentage of alcohol by volume can be calculated by measuring the specific gravity of samples taken before and after fermentation.

The specific gravity is measured using a hydrometer. The level of the sample on the hydrometer scale, read at eye level, is the specific gravity.

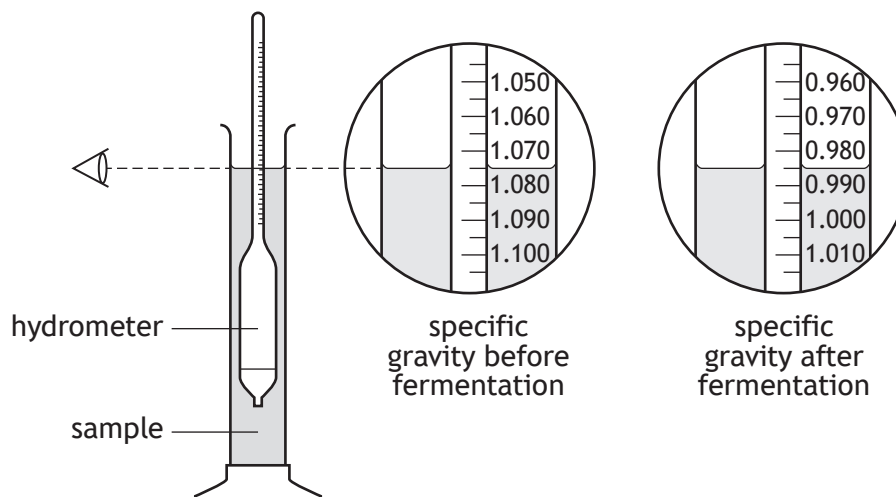

The % alcohol by volume can be calculated using the formula

$$\% \text{ alcohol by volume} = \left(\frac{\text{change in specific gravity}}{0.7362} \right) \times 100$$

Calculate the % alcohol by volume for this sample.

2

[Turn over



5. (continued)

(b) Plant material is used to flavour the ethanol and water mixture. The mixture is then distilled.

(i) The first fraction from the distillation contains toxic methanol and propan-2-one and is discarded.

Describe a chemical test, with the expected result for **both** compounds, that could be used to distinguish between methanol and propan-2-one.

2

(ii) The second fraction from the distillation is collected for bottling as gin. Some of the plant compounds that give gin its flavour are shown.

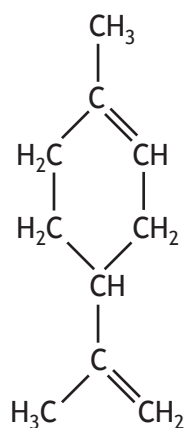

limonene

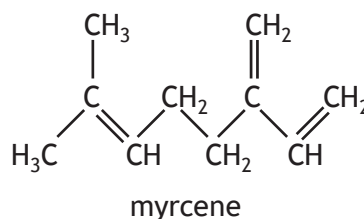

myrcene

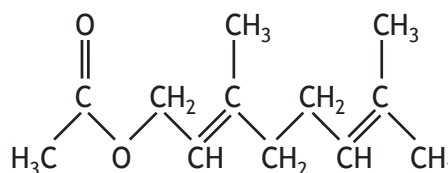

geranyl acetate

(A) Name the class of compounds to which unsaturated hydrocarbons such as limonene and myrcene belong.

1

(B) Circle an isoprene unit on the limonene structure above.

1

(An additional structure, if required, can be found on page 40.)



5. (b) (ii) (continued)

(C) Geranyl acetate can undergo hydrolysis to produce an alcohol and another product.

Name the other product.

1

(c) Gin is often mixed with tonic water before drinking. Tonic water contains quinine, a bitter tasting compound. Historically quinine was used to treat malaria.

To treat malaria an intake of 10.0 mg of quinine per kilogram of body weight is required every 8 hours.

Calculate the mass of quinine required by a 70 kg adult in one day.

2

[Turn over



6. Ammonium nitrate is a commonly used fertiliser.

- (a) (i) (A) Ammonium nitrate is made industrially by adding nitric acid, HNO_3 , to ammonia, NH_3 .

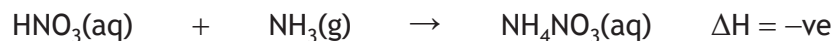

Complete the diagram to show the shape of the enthalpy diagram for this reaction.

1

(An additional diagram, if required, can be found on page 40.)

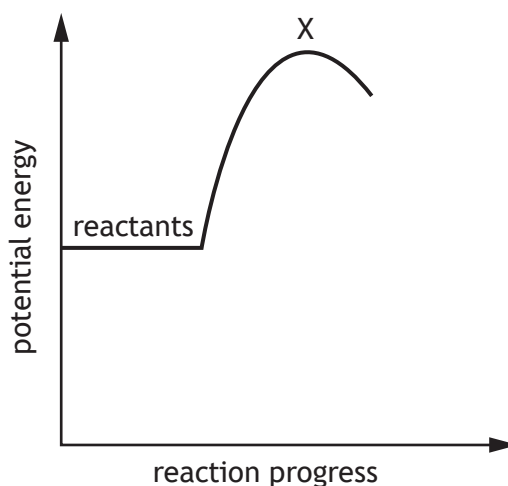

- (B) State the term for the unstable arrangement of atoms formed at the point labelled X on the potential energy diagram above.

1

- (ii) 1316 litres of nitric acid of concentration 9.5 mol l^{-1} was reacted with 220 kg of ammonia ($GFM = 17 \text{ g}$) to produce ammonium nitrate.

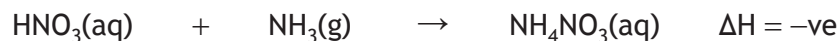

Show, by calculation, which reactant was in excess.

2



6. (a) (continued)

(iii) Ammonium nitrate can also be produced by the reaction

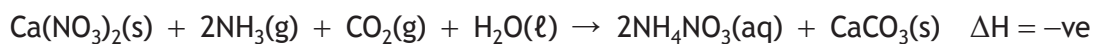

Suggest a reason why the method shown in part (a) (ii) is the preferred industrial route.

1

(b) The rate of reaction can be altered by changing the temperature or using a catalyst.

(i) **Graph 1** shows the distribution of kinetic energies of molecules in a gas mixture.

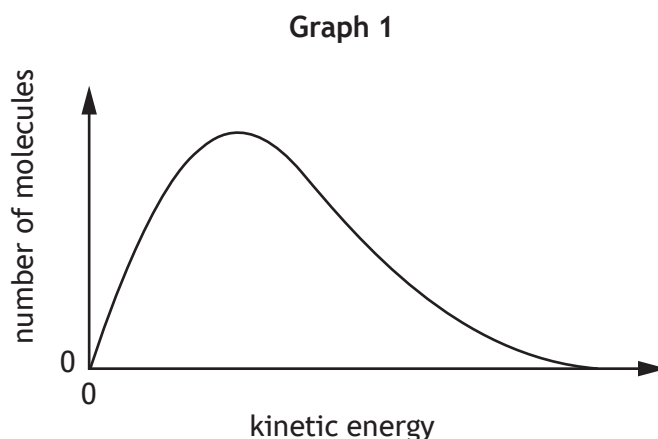

(A) Suggest what is represented by the area under the curve in **Graph 1**.

1

(B) Add a second curve to **Graph 1** to show the distribution of kinetic energies at a higher temperature.

1

(An additional graph, if required, can be found on *page 41*.)

[Turn over



6. (b) (continued)

(ii) In **Graph 2**, the activation energy for the reaction, E_a , is marked on the x -axis.

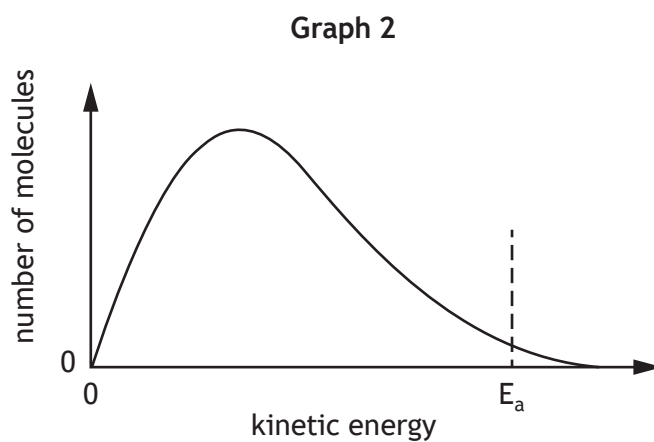

Draw a line on **Graph 2** to show how a catalyst affects the activation energy, E_a .

(An additional graph, if required, can be found on *page 41*.)

1



6. (continued)

- (c) Ammonia used to produce ammonium nitrate can be made by the Haber process.

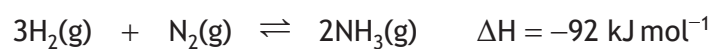

- (i) Reversible reactions, such as the Haber process, can reach a state of dynamic equilibrium in a closed system.

State what is meant by the term dynamic equilibrium.

1

- (ii) (A) The ammonia produced is continuously removed.

Explain how this will affect the production of ammonia.

2

[Turn over



6. (c) (ii) (continued)

(B) A flow diagram of the Haber process is shown.

One way to reduce costs in the process is to use a heat exchanger to transfer excess heat from one part of the process to use in another part of the process.

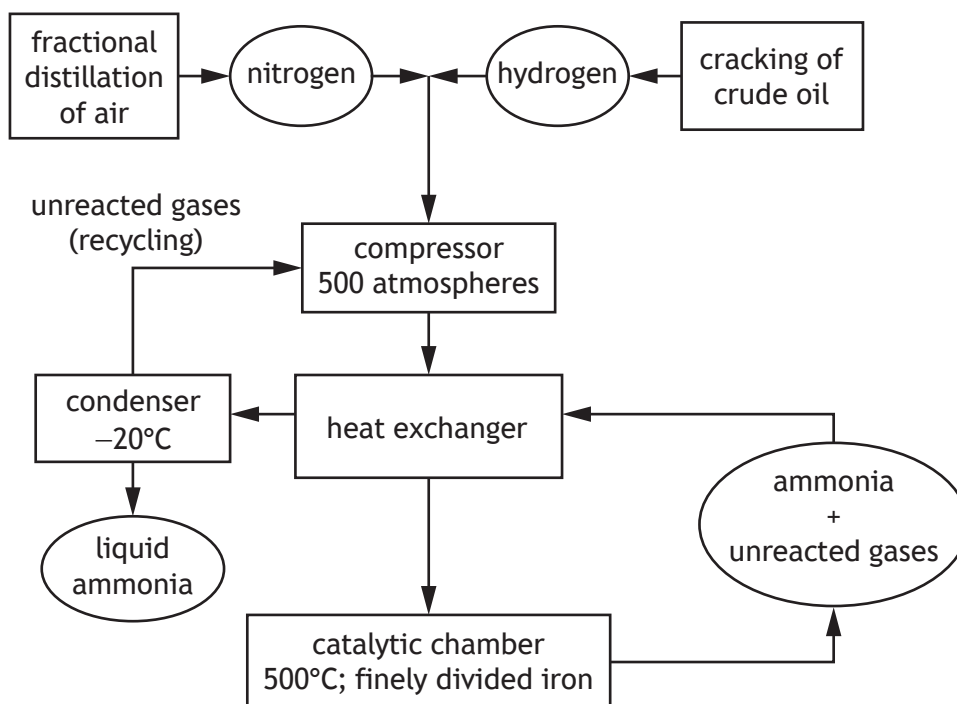

From the flow diagram, state another way that the manufacturing process maximises profit or minimises the impact on the environment.

1

6. (continued)

(d) Ammonia is currently being investigated for use in fuel cells.

The reactions taking place at the electrodes are

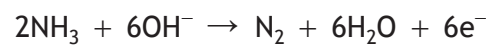
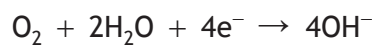

(i) Write the overall redox equation for the reaction taking place in the fuel cell.

1

(ii) Identify the reducing agent in the reaction taking place in the fuel cell.

1

[Turn over



7. Tap water contains a number of dissolved chemicals.

(a) In some parts of the country, tap water contains a high level of dissolved metal salts.

(i) State the term used to describe this type of water.

1

(ii) Soapless detergents are used with this type of water to prevent insoluble scum forming.

The structure of a typical soapless detergent is shown.

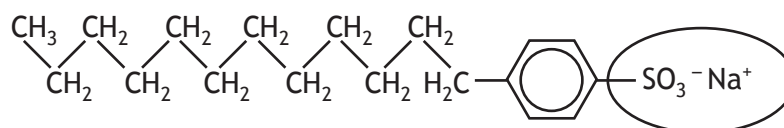

The circled region of the molecule is ionic and dissolves in water.

State the term used to describe this part of the molecule.

1



7. (a) (continued)

- (iii) Calcium ions are commonly found in tap water. The concentration of calcium ions in a tap water sample was determined by titrating with a chemical called EDTA, $C_{10}H_{12}N_2O_8^{4-}$.

A 50.0 cm^3 water sample was collected and reacted with a standard solution of EDTA, with a concentration of $0.0045 \text{ mol l}^{-1}$. The average titre volume was 9.3 cm^3 .

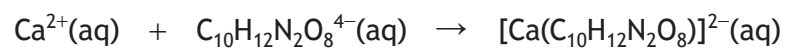

Calculate the concentration, in mol l^{-1} , of calcium ions in the tap water.

3

[Turn over



7. (continued)

(b) Another ion found in tap water is manganese(II), Mn^{2+} .

The manganese(II) ions are oxidised to purple permanganate ions, MnO_4^- . The concentration of permanganate ions can be determined by measuring how much light is absorbed by the solution.

The higher the concentration of permanganate ions in the solution, the more light is absorbed.

The absorbances of several standard solutions of permanganate were measured, and the results plotted.

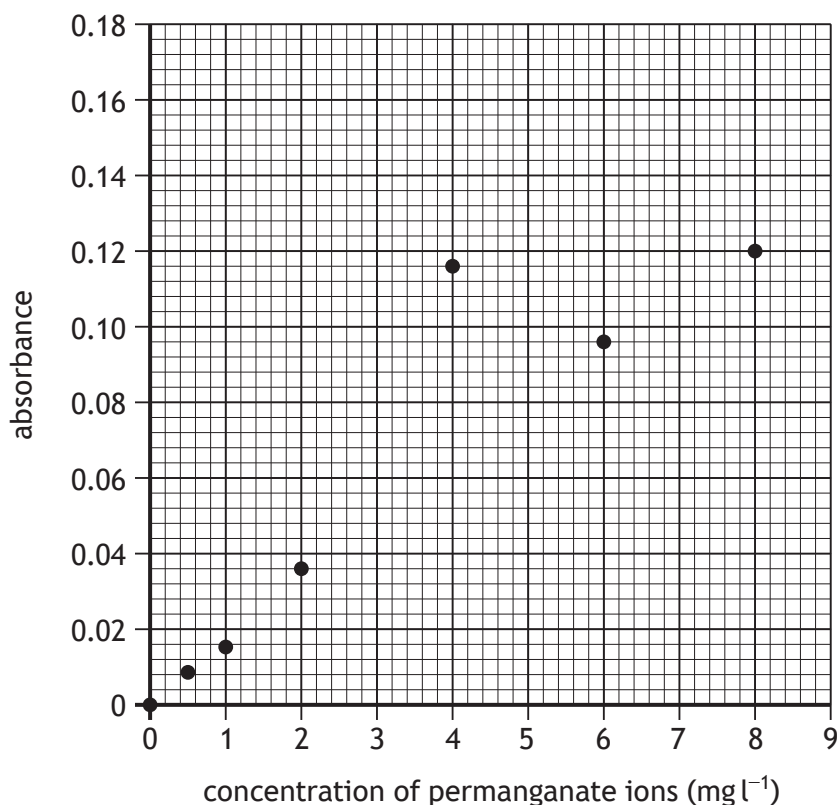

A water sample had an absorbance of 0.08.

Estimate the concentration of permanganate ions, in $mg\ l^{-1}$, in this sample.

1



7. (continued)

(c) Chlorine is added to tap water to make it safe to drink.

The chlorine can react with substances in the water to produce trichloromethane, CHCl_3 .

(i) Trichloromethane is more soluble in water than tetrachloromethane due to the polarities of the molecules.

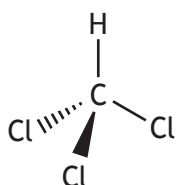

trichloromethane

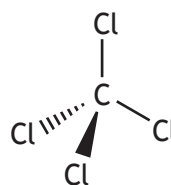

tetrachloromethane

Explain the difference in polarities of trichloromethane and tetrachloromethane molecules.

2

[Turn over



7. (c) (continued)

- (ii) Trichloromethane is used on an industrial scale to produce plastics. The first step in this reaction is to react it with hydrogen fluoride, HF.

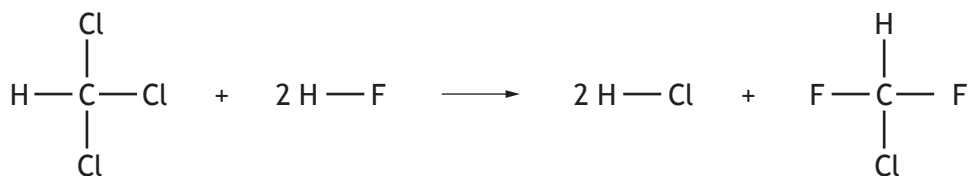

Using bond enthalpies and mean bond enthalpies from the data booklet, calculate the enthalpy change, in kJ mol^{-1} , for the reaction of trichloromethane with hydrogen fluoride.

2



8. Dog food contains many different compounds including fats, vegetable oils, fatty acids, flavour and aroma molecules, proteins, water, antioxidants and emulsifiers.

It is important that dog food has a long shelf life, retains its appearance and texture, as well as providing sufficient nutritional value.

Using your knowledge of chemistry, explain the role of different compounds in dog food.

3

[Turn over



* X 8 1 3 7 6 0 1 3 1 *

9. Haloalkanes are alkane molecules that contain at least one group 7 atom.

(a) The table shows information on the boiling points of some haloalkanes.

Haloalkane	Boiling point (°C)		
	X = Cl	X = Br	X = I
CH ₃ -X	-24.2	3.6	42.4
CH ₃ CH ₂ -X	12.3	38.4	72.3
CH ₃ CH ₂ CH ₂ -X	46.6	71.0	102.0

(i) Using the information in the table, describe **two** different trends in the boiling points.

2

(ii) Name the strongest type of intermolecular forces broken when bromoethane, CH₃CH₂Br, boils.

1



9. (continued)

- (b) Haloalkanes can be classified as primary, secondary or tertiary depending on the position of the group 7 atom.

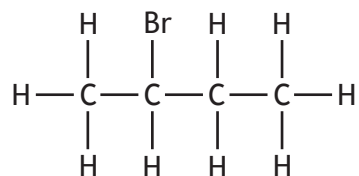

2-bromobutane

- (i) State why 2-bromobutane can be classified as a secondary haloalkane. 1

- (ii) Draw a structural formula for an isomer of 2-bromobutane that is a tertiary haloalkane. 1

[Turn over



9. (continued)

(c) Alkanes can react with group 7 molecules in free radical reactions to form haloalkanes.

Reaction step	Name of step
$\text{Br}_2 \rightarrow 2\text{Br}\cdot$	Initiation
$\text{Br}\cdot + \text{CH}_4 \rightarrow \text{HBr} + \cdot\text{CH}_3$ $\cdot\text{CH}_3 + \text{Br}_2 \rightarrow \text{CH}_3\text{Br} + \text{Br}\cdot$	Propagation
	Termination

(i) State what is required for initiation to take place. 1

(ii) Complete the table to show a possible termination step. 1



9. (continued)

(d) Haloalkanes can react to form alcohols as shown.

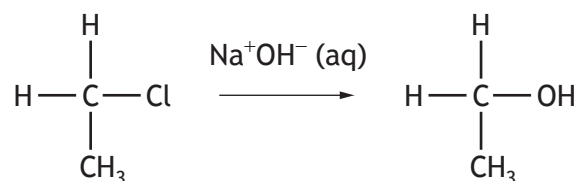

Depending on the structure of the haloalkane used, the alcohol produced can be oxidised to form an aldehyde or ketone.

Compound P was converted to compound R in two steps.

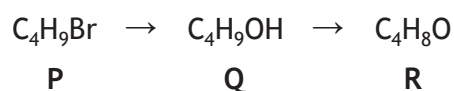

Compound R does not react with Tollens' reagent or Fehling's solution.

Draw a structural formula for compound P.

1

[Turn over



9. (continued)

(e) The structures of two haloalkanes are shown.

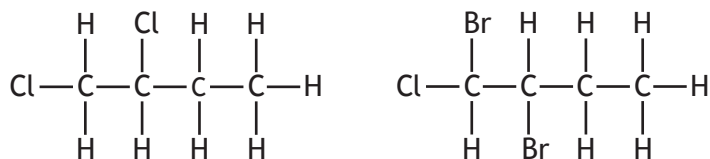

1,2-dichlorobutane

1,2-dibromo-1-chlorobutane

The names of haloalkanes are derived from their structures using the following rules.

1. The name is based on the longest chain of carbon atoms.
2. The presence of group 7 atoms is shown by shortening the name of the group 7 atom.

Group 7 atom	Shortened name
fluorine	fluoro-
chlorine	chloro-
bromine	bromo-

3. The chain is numbered to assign numbers to the group 7 atoms. The numbers should be assigned so the lowest possible numbers are used.
4. If two or more of the same group 7 atoms are present, use the prefixes di, tri or tetra.
5. The shortened name of the group 7 atoms attached to the chain are listed alphabetically (ignoring the prefixes di, tri and tetra for alphabetical purposes).

Using these rules, name this molecule.

1

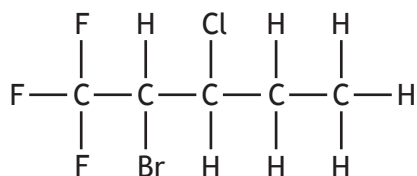

10. A student was given a sample known to be a mixture of magnesium oxide, MgO, and magnesium carbonate, MgCO₃, and asked to determine the mass of magnesium carbonate in the mixture.

- (a) The first step was to accurately measure a mass of 1.5 g of the mixture into a crucible, using a balance.

Describe **fully** how the student could carry out this step.

2

- (b) Metal carbonates decompose on heating to give metal oxides and carbon dioxide gas.



The apparatus was used to strongly heat the mixture of MgCO₃ and MgO. The student used a pair of tongs to lift the lid from time to time.

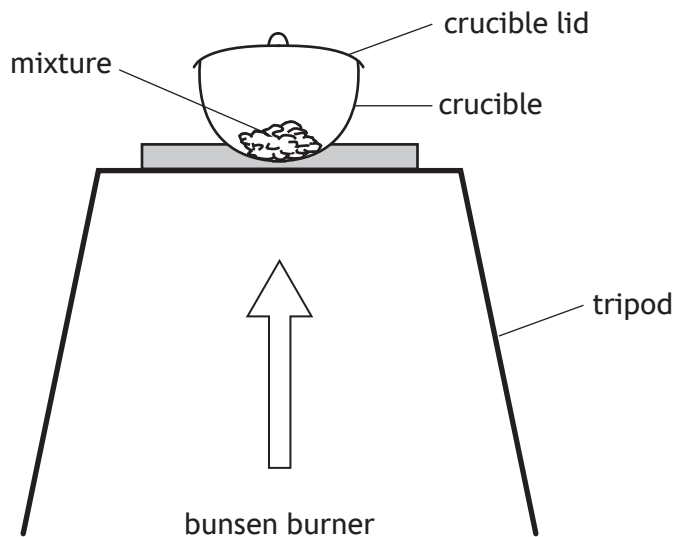

- (i) Suggest why the student had to lift the lid from time to time.

1

[Turn over



10. (b) (continued)

(ii) Explain why a Bunsen burner is a suitable method of heating this reaction.

1

(c) Once the crucible had cooled, the final mass of the sample was determined. The mass of CO₂ lost is used to calculate the mass of MgCO₃ in the mixture. The results are shown below.

Mass of sample before heating	1.598 g
Mass of sample after heating	1.294 g

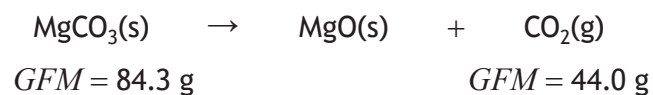

Calculate the mass, in g, of magnesium carbonate present in the mixture.

2



10. (continued)

- (d) Another experiment to determine the mass of magnesium carbonate in the mixture involves measuring the volume of CO_2 produced.

This experiment is carried out by reacting the mixture of magnesium oxide and magnesium carbonate with excess acid. The volume of carbon dioxide gas produced can be measured by collecting the gas over water as shown.

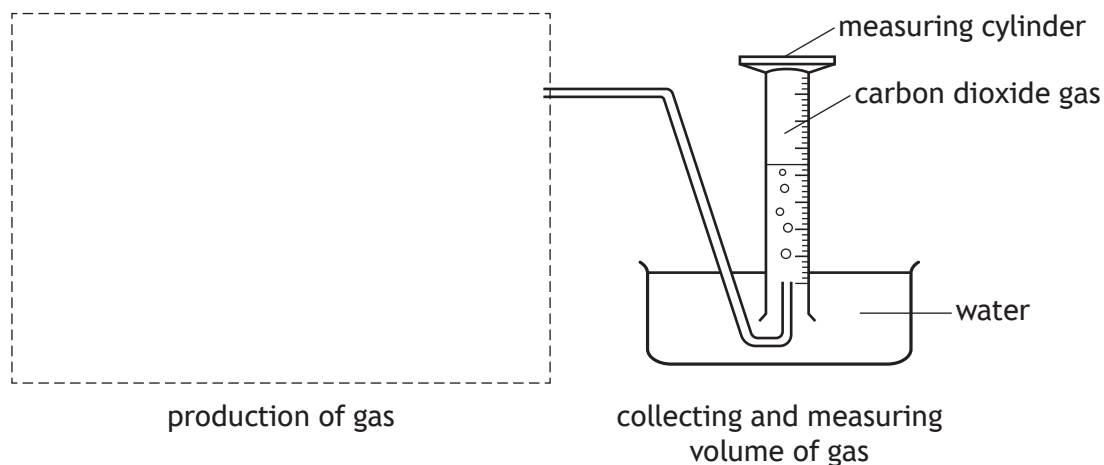

- (i) Complete a labelled diagram to show an apparatus suitable for the production of gas.
(An additional diagram, if required, can be found on *page 42*.)
- (ii) Suggest why carbon dioxide can be collected over water.

1

1

[END OF QUESTION PAPER]



ADDITIONAL SPACE FOR ANSWERS AND ROUGH WORK

Additional structure for use with question 5 (b) (ii) (B)

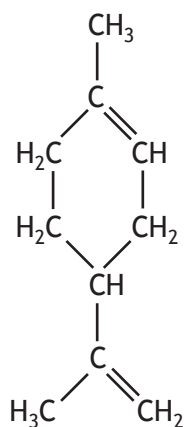

limonene

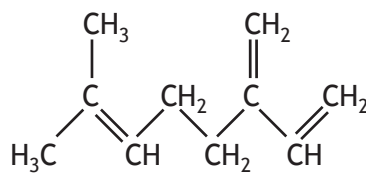

myrcene

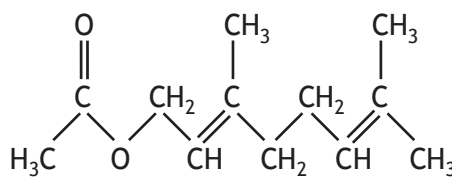

geranyl acetate

Additional diagram for use with question 6 (a) (i) (A)

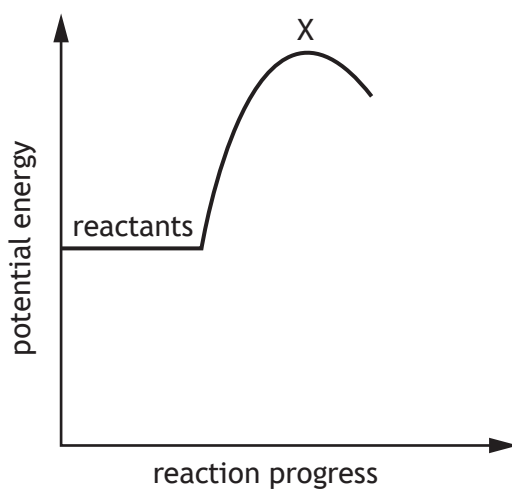

* X 8 1 3 7 6 0 1 4 0 *

ADDITIONAL SPACE FOR ANSWERS AND ROUGH WORK

Additional graph for use with question 6 (b) (i) (B)

Graph 1

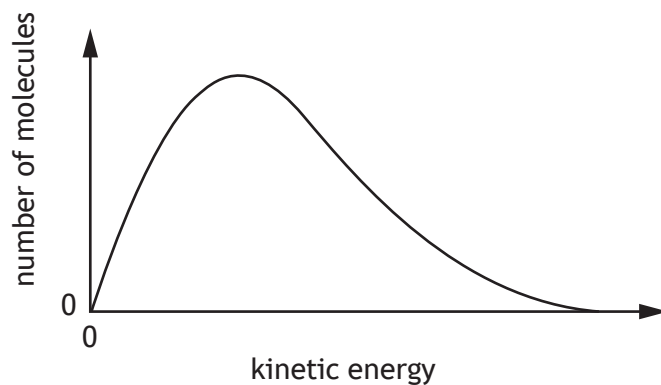

Additional graph for use with question 6 (b) (ii)

Graph 2

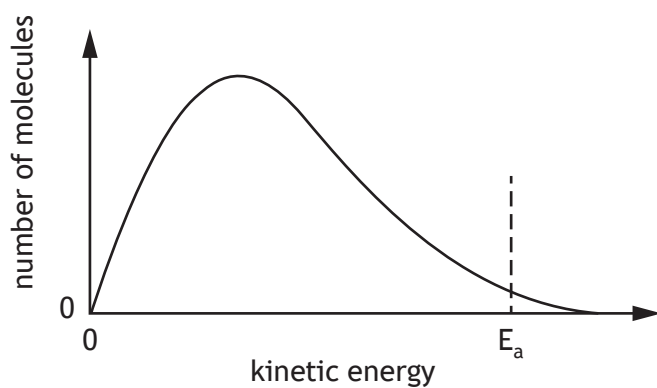

ADDITIONAL SPACE FOR ANSWERS AND ROUGH WORK

Additional diagram for use with question 10 (d) (i)

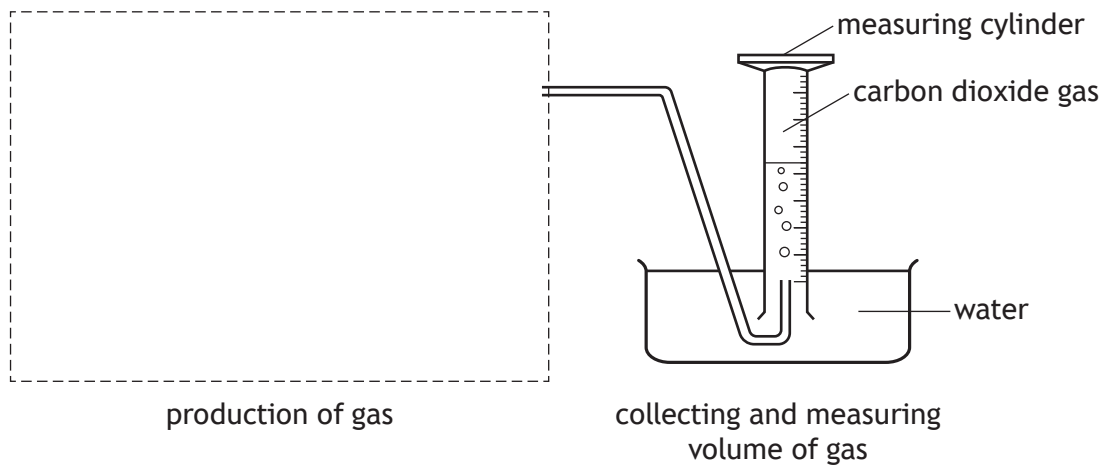

MARKS DO NOT
WRITE IN
THIS
MARGIN

ADDITIONAL SPACE FOR ANSWERS AND ROUGH WORK



MARKS DO NOT
WRITE IN
THIS
MARGIN

ADDITIONAL SPACE FOR ANSWERS AND ROUGH WORK

