



National  
Qualifications  
2021 ASSESSMENT RESOURCE

---

**X835/76/11**

**Graphic Communication  
Supplementary sheets**

Duration — 2 hours

---

Supplementary sheets 1 to 5, for use with questions 1, 2 and 3.



\* X 8 3 5 7 6 1 1 \*

ASSEMBLED ORTHOGRAPHIC

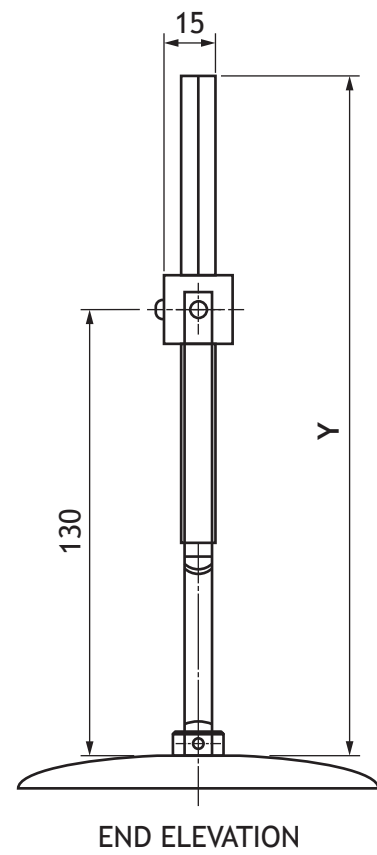
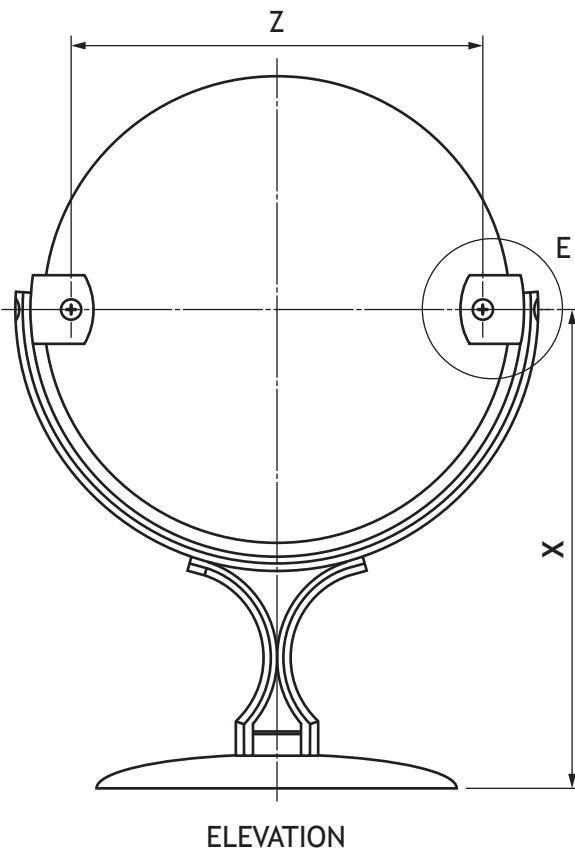
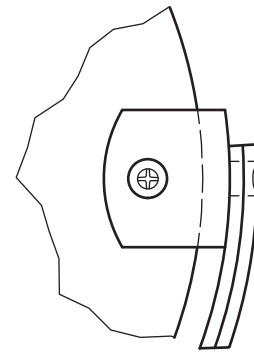
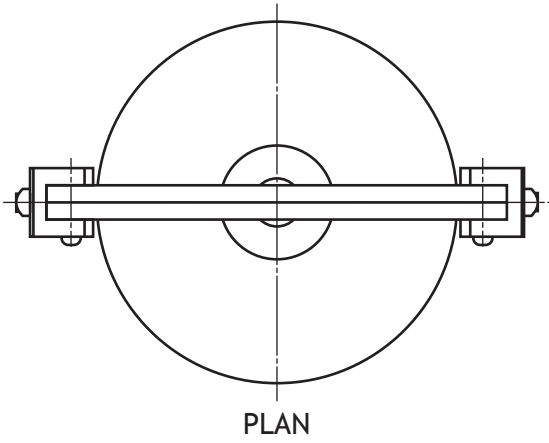

MIRRORED GLASS PANEL (1:2.5)

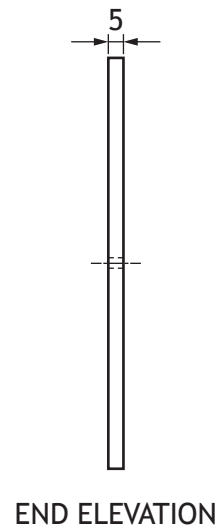
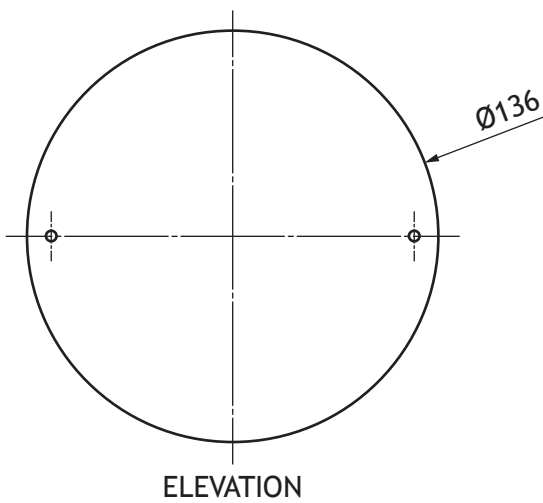

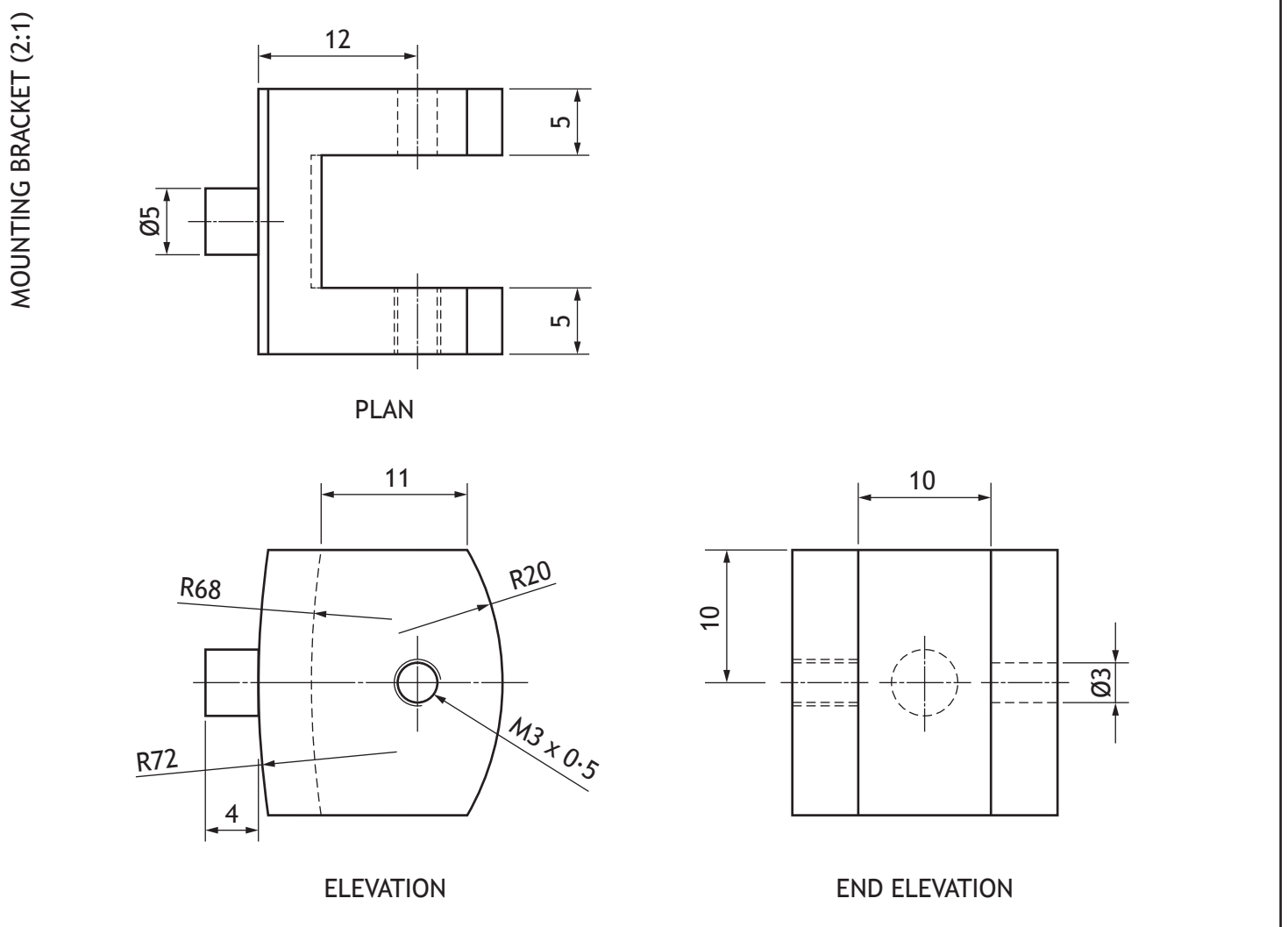
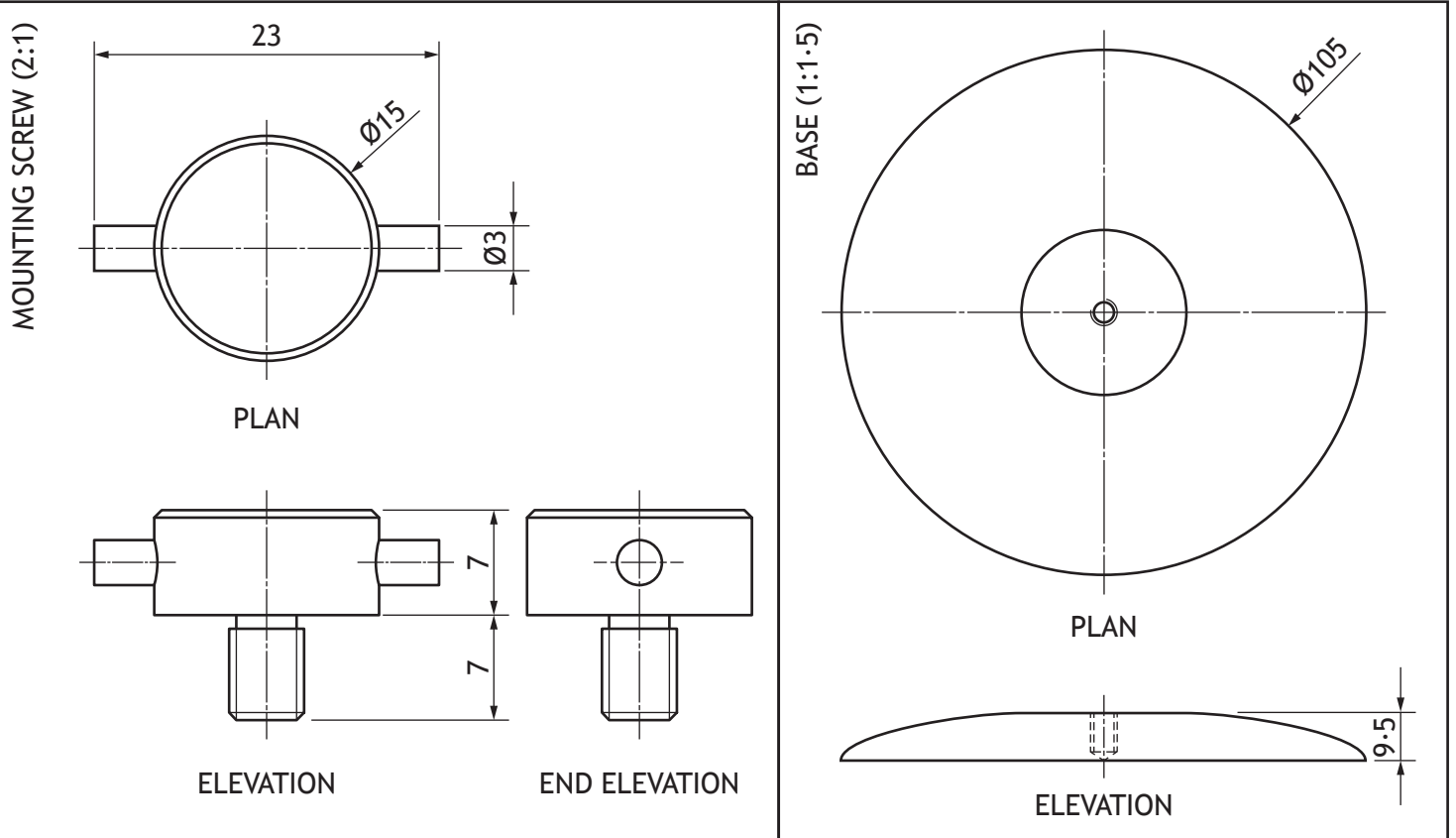

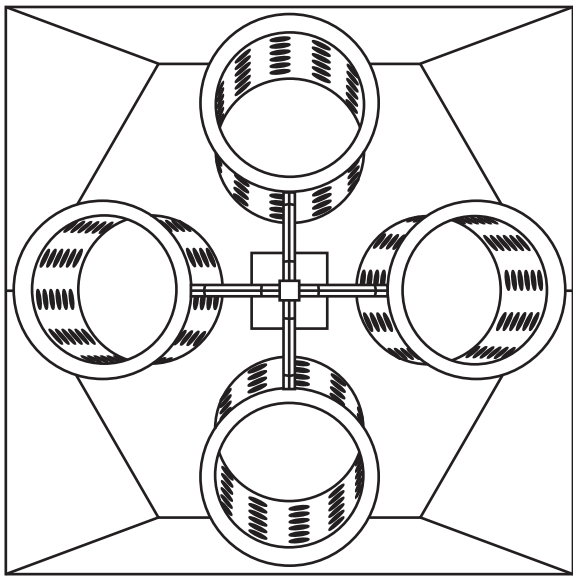

PLAN



PICTORIAL ILLUSTRATION

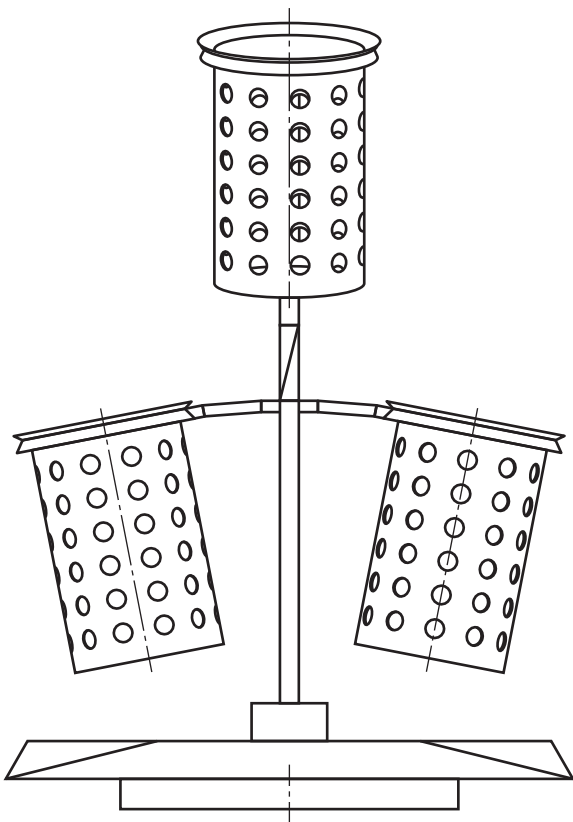

ELEVATION

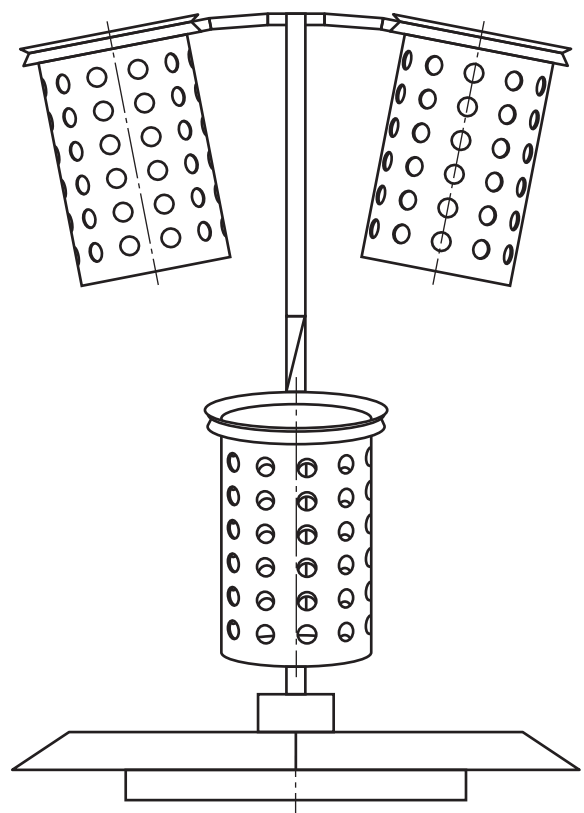

END ELEVATION

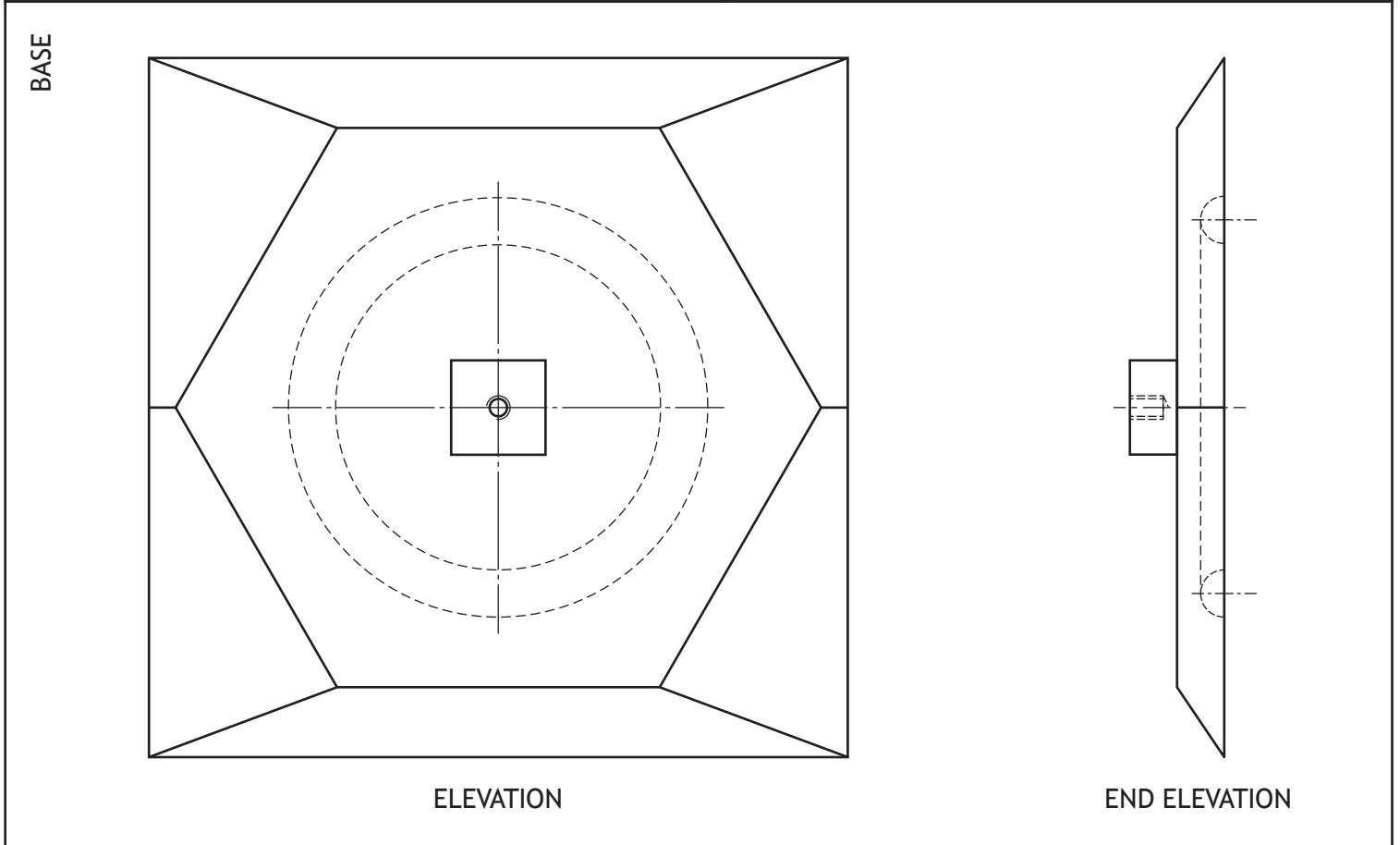
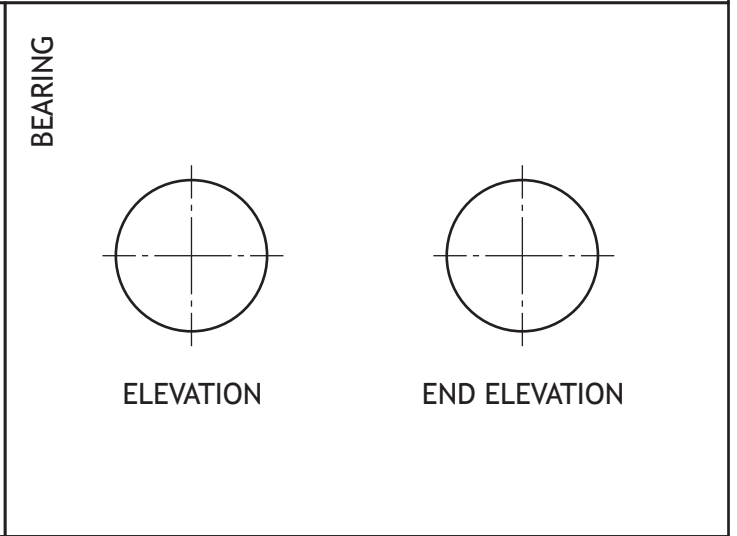
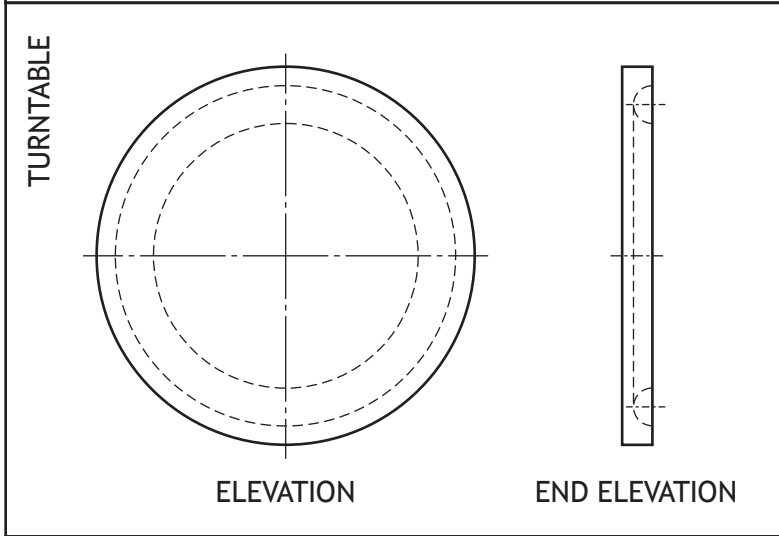
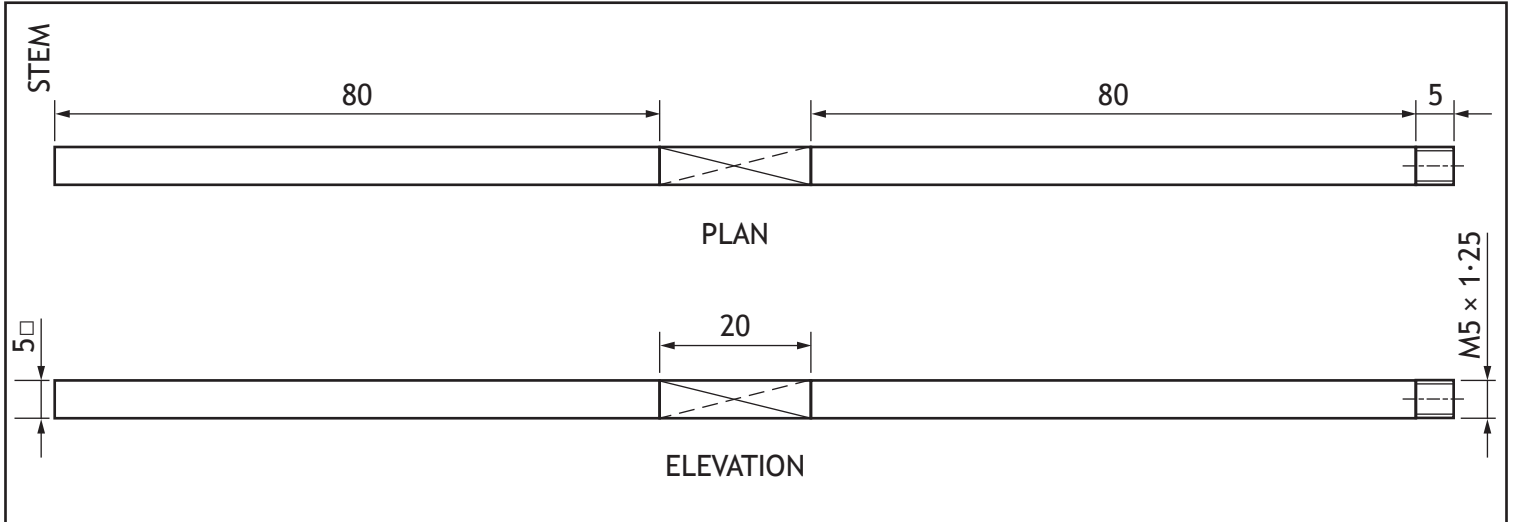



EST. 2018

SPECIALITY TEA & COFFEE

# THE CAFE

EATERY & TAKEAWAY

Evening Menu **3 TO 10**  
MONDAY - SUNDAY

## STARTERS

SOUP OF THE DAY . . . . .	£2.95
CHICKEN DIPPERS . . . . .	£3.95
GARLIC MUSHROOMS . . . . .	£3.95
PRAWN COCKTAIL . . . . .	£4.25
BUFFALO WINGS . . . . .	£5.25
HALLOUMI BITES . . . . .	£3.50
MOZZARELLA BALLS . . . . .	£3.25
BRUSCHETTA . . . . .	£4.50

## SHAKE IT!

### FRESH MILKSHAKES

- BANANA
- STRAWBERRY
- CHOCOLATE
- VANILLA

ONLY  
**£3.50**

## — HOT DOGS —

- THE CAFE DOG** | 10 | Enjoy our classic hot dog in a freshly baked bun. served with our secret sauce.
- CHICAGO DOG** | 12 | 100% beef hot dog served with onions, tomatoes, pickles and mustard.
- TEX MEX DOG** | 12 | 100% beef hot dog with jalapeno's, spicy chilli and cheddar cheese.
- SALSA DOG** | 12 | 100% pork hot dog under tangy tomato salsa and soured cream.
- THE BIG DOG** | 15 | Foot long pork hot dog, served with crispy onions and bacon. Finished with relish and mustard.



TWO MEALS for £15  
Special Offer  
**2 MEALS FOR £15**  
On All Main Meals  
MONDAY to FRIDAY

### LOCAL PRODUCE

We support local farmers and buy our ingredients from local suppliers as much as possible.

### FRESHLY MADE

We make all of our food fresh every day in our kitchen. We never reheat food or use frozen products.

### FAIR TRADE

We use fair trade coffee and chocolate.

## — MAIN MEALS —

- HUNTERS CHICKEN** | 13 | Chicken breast topped with BBQ sauce and cheese. Served with chips and peas.
- CHICKEN CURRY** | 14 | Chef's special chicken curry served with rice and naan bread.
- STEAK & ALE PIE** | 14 | Scrumptious steak & ale pie in a rich gravy. Served with mash and market veg.
- LASAGNE & CHIPS** | 13 | Vegetable lasagne with a mature cheddar sauce. Served with garlic bread.
- FISH & CHIPS** | 13 | Beer-battered haddock with triple cooked chips, peas and tartare sauce.

## — THE GRILL —

- BIG MIXED GRILL** | 20 | Gammon steak, pork chop, rump steak, sausage, chips and onion rings.
- FLAME BURGER** | 14 | 100% beef patty with cheese and bacon on a seeded bun. Served with chips.
- FILLET STEAK** | 18 | Prime British beef, cooked to your preference and served with steamed vegetables and chips. Ask your server for sauces.
- CATCH OF THE DAY** | 16 | Freshly grilled fish of the day served with boiled potatoes and market veg.

**ROOM FOR MORE?**

TRY OUR DELICIOUS DESSERTS!

ALL DESSERTS  
**£4.50**

- **STICKY TOFFEE PUDDING**  
A moist sponge with dark sticky toffee topping
- **LEMON MERINGUE**  
A sweet short crust pastry base filled with lemon filling and topped with peaks of meringue.
- **APPLE & RHUBARB CRUMBLE**  
Pieces of apple and rhubarb topped with a crunchy crumble.
- **ICE CREAM SUNDAE**  
Vanilla and chocolate ice-cream with biscuit and toffee.

**THANKS!**

For visiting.  
Please visit our website and vote for us to help us to become

**#1**

restaurant in Scotland.

[BLANK PAGE]

DO NOT WRITE ON THIS PAGE

*Acknowledgement of copyright*

Question 3    file404/shutterstock.com