



NQ
NATIONAL
QUALIFICATIONS

Technological Studies

Data Booklet

Advanced Higher

 **SQA**

Technological Studies Data Booklet

Advanced Higher

For use in National Qualification Courses
leading to the 2009 examinations and beyond.

Published date: July 2008
Publication code: BB4471
ISBN: 978 1 85969 613 2

Published by the Scottish Qualifications Authority
The Optima Building, 58 Robertson Street, Glasgow G2 8DQ
Ironmills Road, Dalkeith, Midlothian EH22 1LE

www.sqa.org.uk

The information in this publication may be reproduced in support of SQA qualifications. If it is reproduced, SQA should be clearly acknowledged as the source. If it is to be used for any other purpose, then written permission must be obtained from the Publishing Team at SQA. It must not be reproduced for trade or commercial purposes.

© Scottish Qualifications Authority 2008

For an up-to-date list of prices visit the **Publication Sales and Downloads** section of SQA's website.

This document can be produced, on request, in alternative formats, including large type, braille and numerous community languages.

For further details telephone SQA's Customer Contact Centre on 0845 279 1000.

Contents

Preface	1
Basic Units and Decimal Prefixes	2
Applied Electronics	3
Basic Equations	3
555 timer, 7493 IC, 7447 IC	4
Typical Operational Amplifier Circuits	5
Schmitt Trigger, Wien Bridge Oscillator	8
DAC, ADC	9
Graph for Thermistors, Thermocouple and LDR	10
Systems and Control	13
Symbols for Flowcharts	13
Assembler Code Instruction Set	14
Structures and Materials	17
Basic Formulae	17
Young's Modulus and Stress data	18
Bending of beams—configurations	19
Second Moment of Area (I) for Common Sections	20
Dimensions and Properties of Standard Sections	21

Preface

This data booklet is intended for use by candidates in examinations in Technological Studies at Advanced Higher level. It is recommended that candidates should become familiar with the contents of the data booklet through use in undertaking units of these courses.

It should be noted that the range of data contained in the booklet has been limited to that syllabus content which may be assessed through written examination papers. This range should be supplemented by other resource material as necessary during the course, eg by using data sheets. However, should any additional information (or data not included in this booklet) be required in an examination, such information will be included in the examination paper.

Teachers/lecturers should note that all of the material contained in this booklet is likely to be examined at some time. With regard to tables of information, not every entry in a table will necessarily be involved in examination questions.

From the variety of data offered in this booklet, candidates will be expected to demonstrate the ability to select an appropriate:

- item of information
- formula
- material property
- operational amplifier circuit
- assembler code instruction.

Basic Units and Decimal Prefixes

Basic Units			
Quantity	Symbol	Unit	Abbreviation
Length	l, L	metre	m
Distance	s, x	metre	m
Time	t	second	s
Velocity	v	metre/second	m/s
Mass	m	kilogram	kg
Force	F	newton	N
Work	W	joule	J
Energy	E	joule	J
Power	P	watt (J/s)	W
Stress	σ	newton/metre ²	N/m ²
Strain	ϵ	no unit	
Temperature	T, t	kelvin, celsius	K, °C
Current	I	ampere (amp)	A
Voltage	V	volt	V
Resistance	R	ohm	Ω
Frequency	f	hertz	Hz

Decimal Prefixes		
Prefix	Symbol	Multiplying Factor
tera	T	10^{12}
giga	G	10^9
mega	M	10^6
kilo	k	10^3
milli	m	10^{-3}
micro	μ	10^{-6}
nano	n	10^{-9}
pico	p	10^{-12}

Applied Electronics

Basic Equations

Ohm's law

$$V = IR$$

Resistors in series

$$R_T = R_1 + R_2 + R_3$$

Resistors in parallel

$$\frac{1}{R_T} = \frac{1}{R_1} + \frac{1}{R_2} + \frac{1}{R_3}$$

for 2 resistors in parallel

$$R_T = \frac{R_1 R_2}{R_1 + R_2} \quad \left(R_T = \frac{\text{product}}{\text{sum}} \right)$$

Kirchhoff's 1st Law

$$\sum I = 0$$

(Algebraic sum of currents at a node is zero)

Kirchhoff's 2nd Law

$$\sum E = \sum IR$$

(Algebraic sum of supply voltages = sum of voltage-drops, in a closed loop)

Voltage Divider Rule

$$\frac{V_1}{V_2} = \frac{R_1}{R_2}$$

(Ratio of Voltages = Corresponding Ratio of Resistances)

Electrical Power

$$P = VI = \frac{V^2}{R} = I^2 R$$

Bi-polar transistor gain

$$h_{FE} = \frac{I_c}{I_b}$$

555 Timer (astable mode)

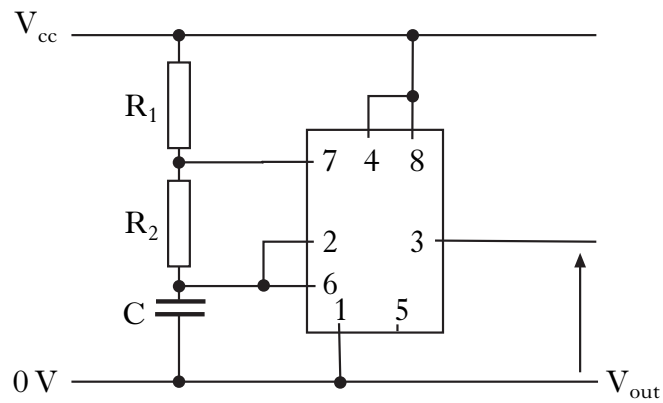

Mark: $T_1 = 0.7(R_1 + R_2)C$

Space: $T_2 = 0.7 R_2 C$

Frequency: $f = \frac{1.44}{(R_1 + 2R_2)C}$

7493 4-bit binary counter

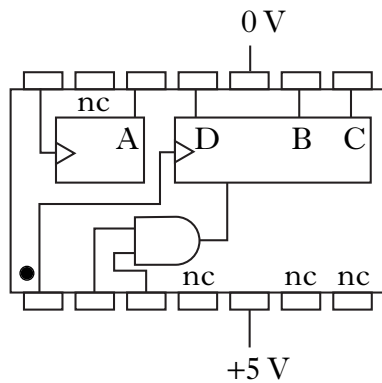

7447 BCD-7 segment display decoder

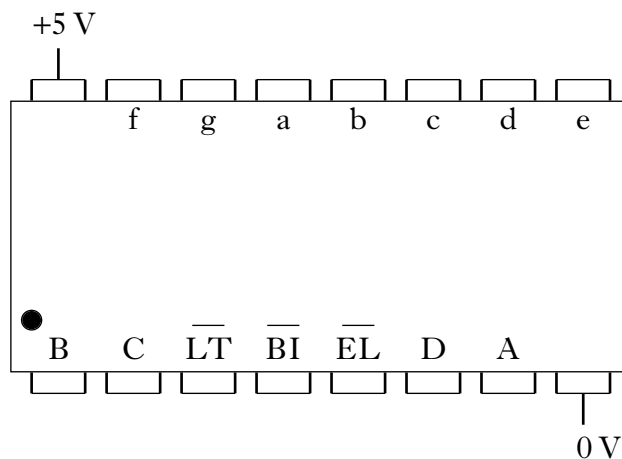

Typical Operational Amplifier Circuits

V_o = output voltage

V_i = input voltage

V_{cc} = supply voltage

R_f = feedback resistance

R_i = input resistance

A_v = gain = $\frac{\text{output voltage}}{\text{input voltage}}$

Note: Op-amp output saturates at 85% of V_{cc}

Inverting

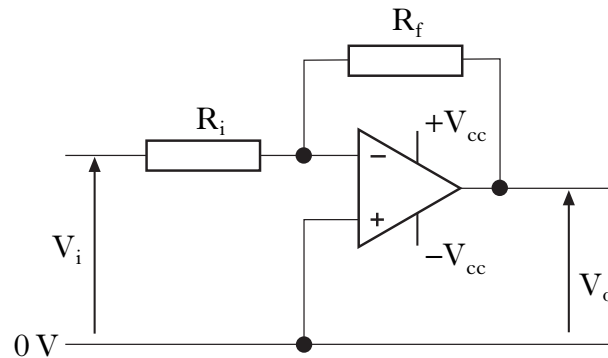

$$A_v = \frac{V_o}{V_i}$$

$$A_v = -\frac{R_f}{R_i}$$

$$V_o = -\frac{R_f}{R_i} V_i$$

Non-inverting

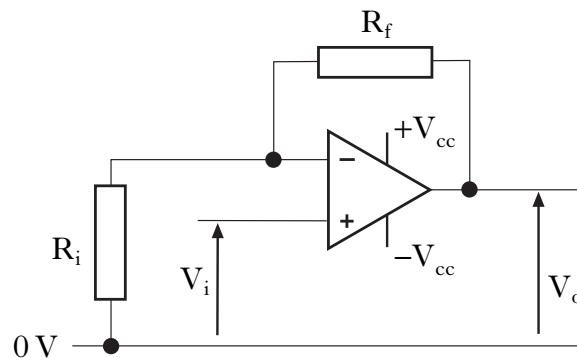

$$A_v = \frac{V_o}{V_i}$$

$$A_v = 1 + \frac{R_f}{R_i}$$

$$V_o = \left(1 + \frac{R_f}{R_i}\right) V_i$$

Comparator

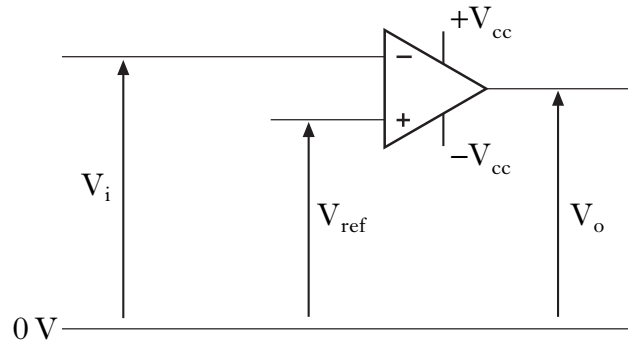

If $V_i < V_{ref}$, then V_o saturates positively (85% of $+V_{cc}$)

If $V_i > V_{ref}$, then V_o saturates negatively (85% of $-V_{cc}$)

Difference Amplifier

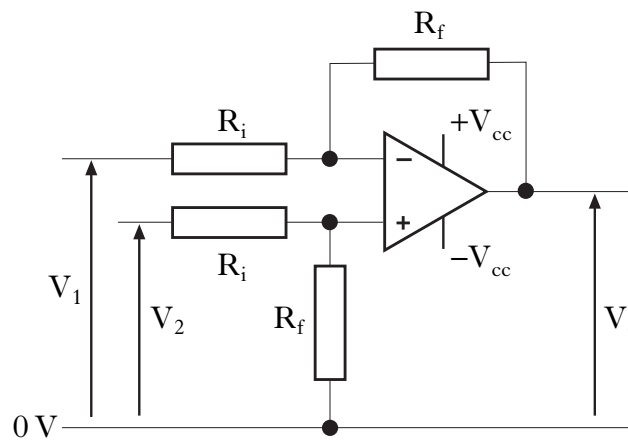

$$A_v = \frac{V_o}{(V_2 - V_1)}$$

$$A_v = \frac{R_f}{R_i}$$

$$V_o = \frac{R_f}{R_i}(V_2 - V_1)$$

Summing Amplifier

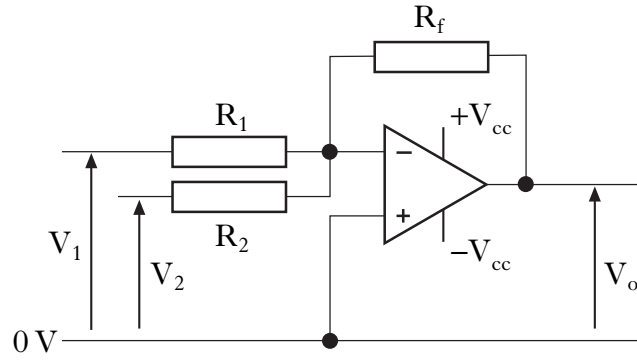

$$A_{v1} = -\frac{R_f}{R_1} \quad A_{v2} = -\frac{R_f}{R_2} \quad A_{vn} = -\frac{R_f}{R_n}$$

$$V_o = (A_{v1}V_1) + (A_{v2}V_2) + \dots$$

$$V_o = -R_f \left(\frac{V_1}{R_1} + \frac{V_2}{R_2} + \dots \right)$$

Integrator

(Considered to be perfect op-amp)

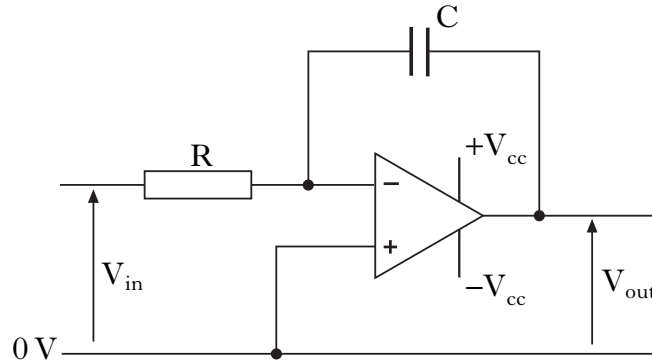

$$\Delta V_{out} = -\frac{1}{RC} \int V_{in} dt$$

Schmitt Trigger

(Considered to be perfect op-amp)

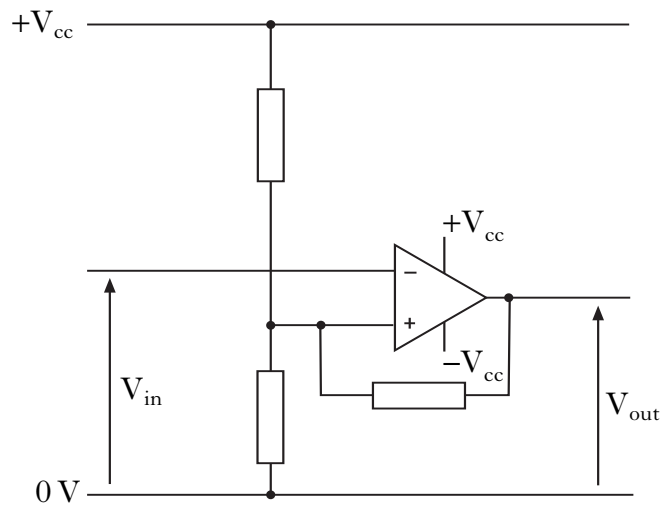

Wien Bridge Oscillator

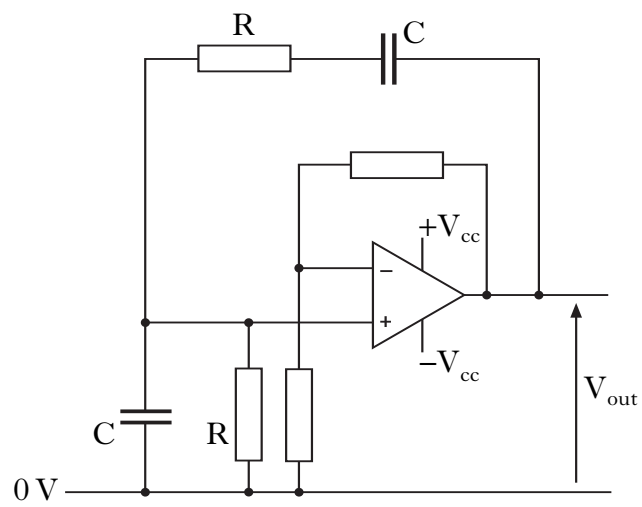

$$\text{Frequency: } f = \frac{1}{2\pi RC}$$

4-bit D-A converter

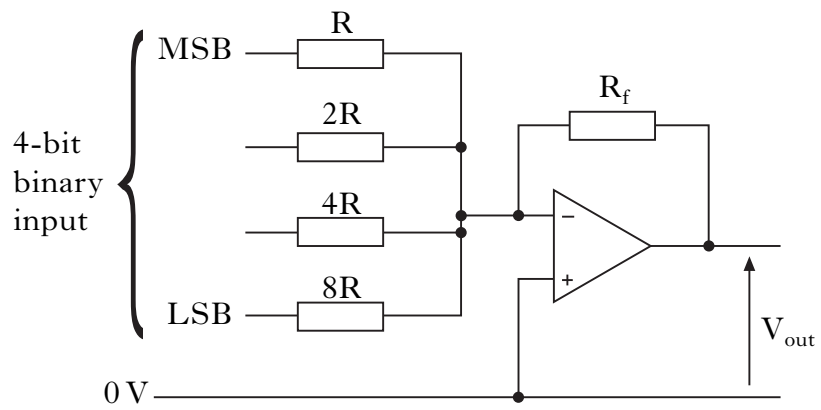

A-D converter

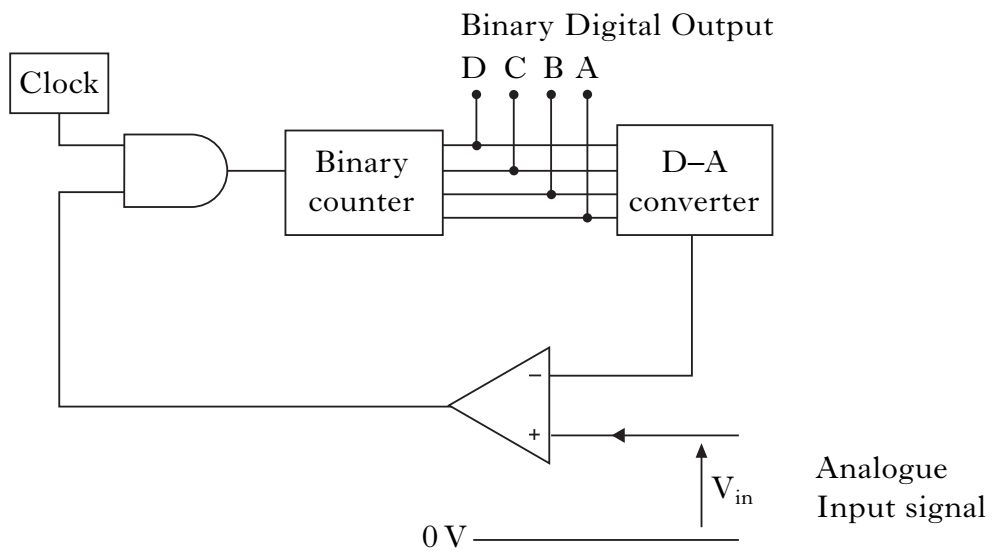

Graphs for Thermistors, Thermocouple and LDR

Thermistors: Resistance-temperature characteristics

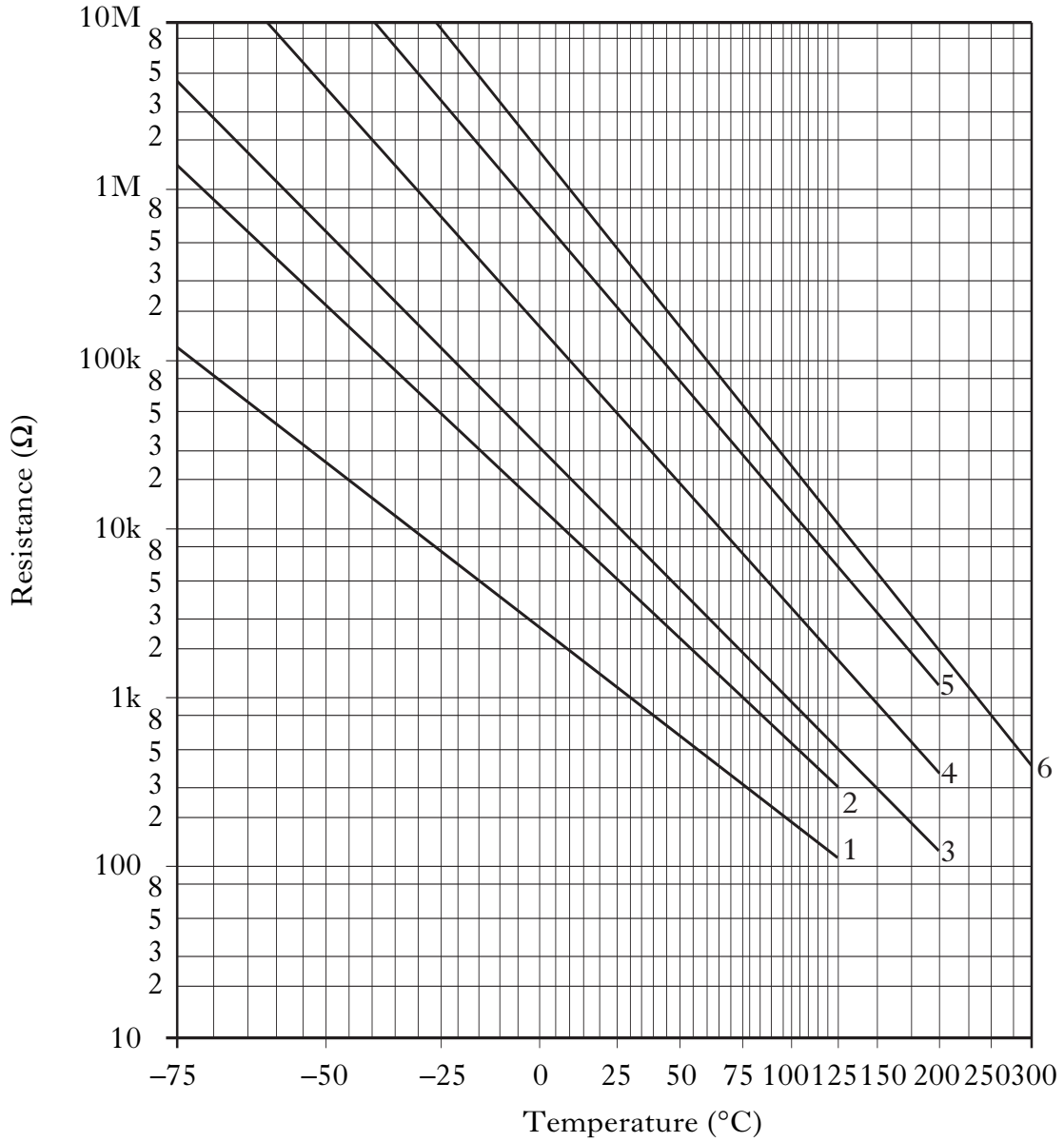

Thermocouple

Typical temperature gradient for type K thermocouple

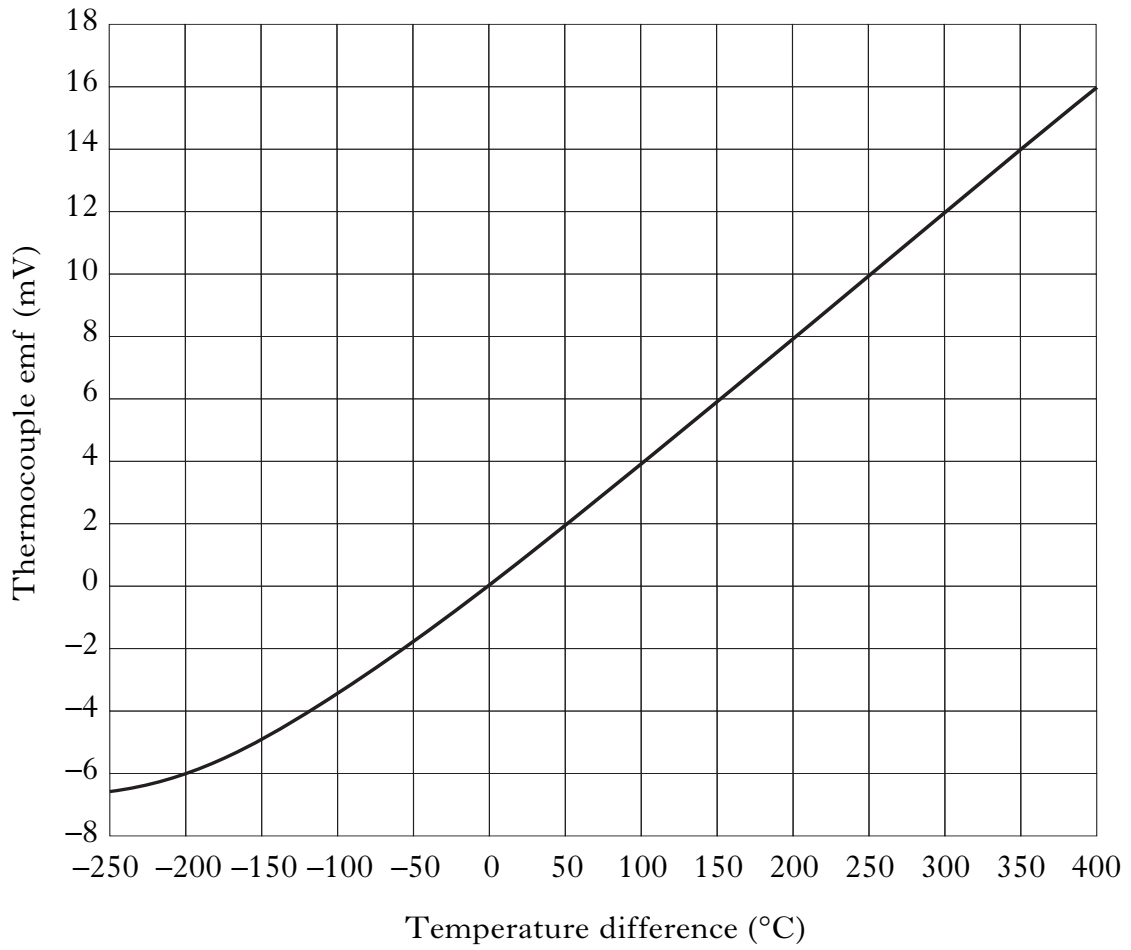

Light Dependent Resistor (LDR)

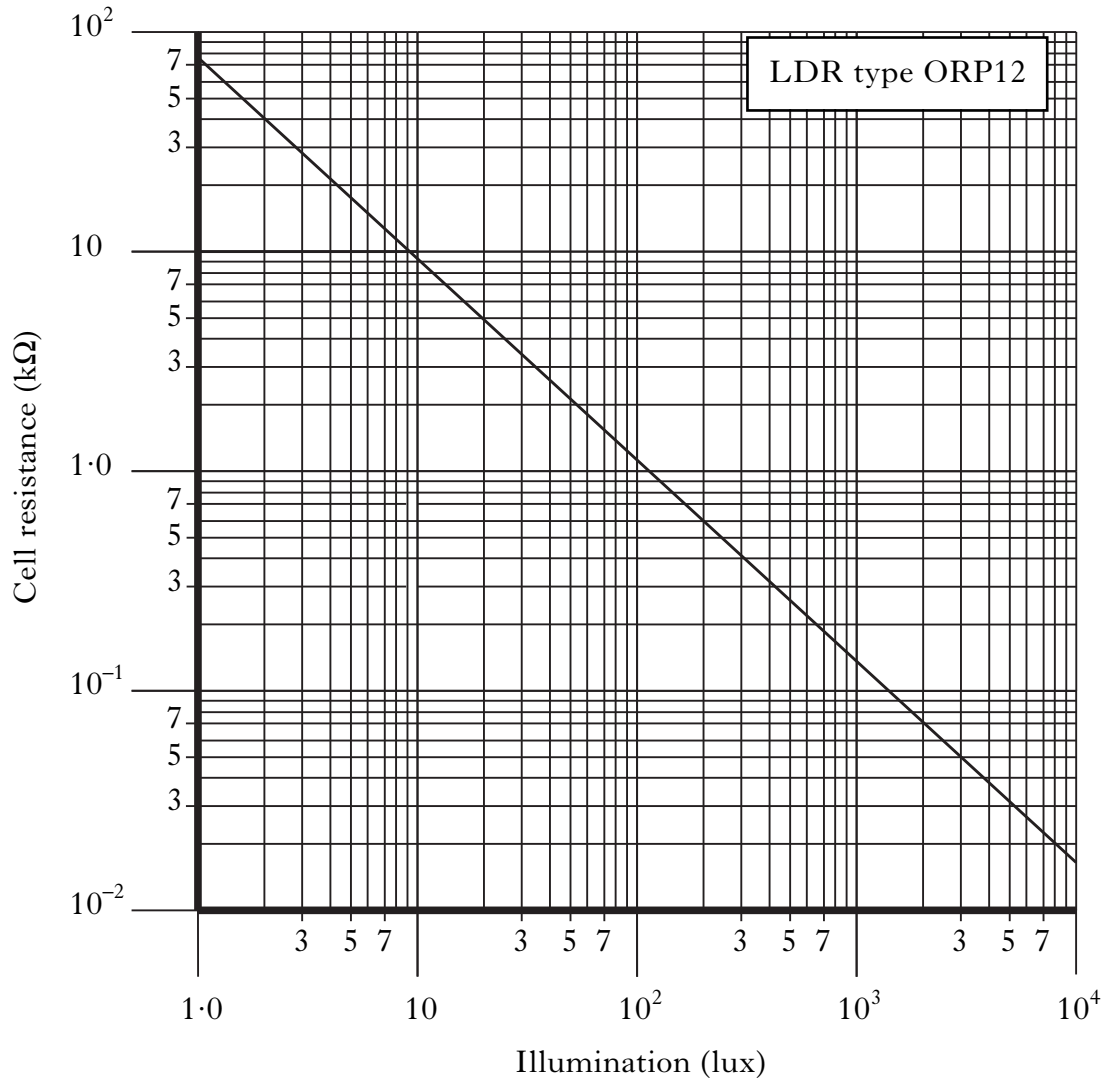

Systems and Control

Symbols for Flowcharts

Terminator symbol



Used for the start and end of a main program or sub-procedure.

Line symbol



Indicates the direction of program flow. For flow down or to the right arrows are not needed. For flow upwards or to the left, arrows are added.

Input/Output symbol



Used to control outputs or to show that data is being received.

Process symbol



Used for operations which take place within the microcontroller.

Decision symbol

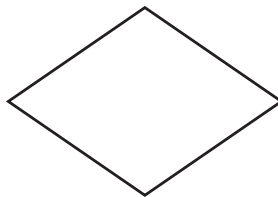

Program flow is determined by a “yes” or “no” answer to the question in the box.

Sub-procedure symbol



Used to call a sub-procedure.

Special Function registers	
PORTB	Input/output PORT used for external communications with the microcontroller.
STATUS REGISTER	Contains information about microcontroller operation.
STATUS, RP0	The register page bit (RP0) specifies the current Special Function Register page (0 or 1). TRISB is on page 1.
STATUS, C	The carry bit (C) is set (=1) if the result of an arithmetical operation is positive (>=0). It is clear (=0) if the result is negative (<0).
STATUS, Z	The zero bit (Z) is set if the result of an arithmetical operation is zero. It is clear (=0) if the result of the operation is not zero.
TRISB	Sets up PORTB: TRISB bits that are set (=1) make corresponding PORTB pins inputs; TRISB bits that are clear (=0) make corresponding PORTB pins outputs. To move an appropriate value to TRISB: Select Page 1 is using STATUS register bit RP0; Move the appropriate value for TRISB into W; Move the value in W to TRISB; Select page 0 using STATUS register bit RP0.
Instruction syntax	
<p>The instruction movlw d'50' consists of a mnemonic and an operand: mnemonic: movlw (move literal into the working register) operand: d'50' (the decimal number 50 is the literal to be moved)</p> <p>There are four kinds of operands:</p> <ul style="list-style-type: none"> f—The name of a file eg PORTB or COUNTER b—A number between 0 and 7 specifying a bit within a file k—A literal or constant between 0 and 255, with two possible formats: <ul style="list-style-type: none"> decimal eg d'200' (the decimal number 200) binary eg b'11001000' (the binary equivalent of 200) d—The destination for the result of a calculation, with two possibilities: <ul style="list-style-type: none"> F—the result is stored in the specified file W—the result is stored in the working register <p>A value will remain in working register or a file until it is overwritten or cleared.</p>	

Mnemonic	Operand	Instruction
bsf	f,b	(bit set file)—set a single bit of a file to logic level ‘1’
bcf	f,b	(bit clear file)—set a single bit of a file to logic level ‘0’
btfss	f,b	(bit test file skip if set)—if the specified bit of a file is set (=1) the next instruction is skipped
btfsc	f,b	(bit test file skip if clear)—if the specified bit of a file is clear (=0) the next instruction is skipped
movlw	k	(move literal to W)—move a constant into working register
movwf	f	(move W to file)—move the value in working register to a file
movfw	f	(move file to W)—move the value in a file to working register
clrf	f	(clear file)—make the value in a file zero
clrw		(clear W)—make the value in working register zero
addlw	k	(add literal to W)—add a constant to the value in working register
addwf	f,d	(add W to file)—add value in working register to value in a file
sublw	k	(subtract W from literal)—subtract the value in working register from a constant
subwf	f,d	(subtract W from file)—subtract the value in working register from the value in a file
incf	f,d	(increment file)—add 1 to the value in a file
decf	f,d	(decrement file)—subtract 1 from the value in a file
decfsz	f,d	(decrement file skip if zero)—subtract 1 from the value in a file; skip next instruction if the value in the file is zero

Mnemonic	Operand	Instruction
xorlw	k	(exclusive OR literal with W)—perform logical XOR on corresponding bits of constant and working register (store result in W). If the literal is equal to the value in W the result is zero
xorwf	f,d	(exclusive OR working register with file)—perform logical XOR on corresponding bits of W and a file. If value in file is equal to value in W result is zero
andlw	k	(AND working register with file)—perform logical AND on corresponding bits of literal and W (store result in W)
andwf	f,d	(AND working register with file)—perform logical AND on corresponding bits of W and a file
rlf	f,d	(rotate left file)—move all bits of a file one place to the left; move bit 7 to carry bit; move carry bit to bit 0
rrf	f,d	(rotate right file)—move all bits of a file one place to the right; move bit 0 to carry bit; move carry bit to bit 7
comf	f,d	(complement file)—‘twos complement of file’ 1’s become 0’s and 0’s become 1’s. Result in W or f.
Flow and control operations		
goto	label	jumps to the instruction at the label
call	name	jumps to and runs the sub-procedure with that name
return		return from sub-procedure to next instruction after the call instruction
nop		no operation—creates a short time delay
sleep		enter low power mode—used at the end of a program

Structures and Materials

Basic Formulae

Moment of a force

$$M = Fx$$

x is the perpendicular distance

Principle of Moments

$$\Sigma M = 0$$

Conditions of equilibrium

$$\Sigma F_h = 0$$

$$\Sigma F_v = 0$$

$$\Sigma M = 0$$

Stress

$$\sigma = \frac{F}{A}$$

Strain

$$\varepsilon = \frac{\Delta \ell}{\ell}$$

Young's Modulus

$$E = \frac{\sigma}{\varepsilon}$$

General Bending Equation

$$\frac{M}{I} = \frac{\sigma}{y} = \frac{E}{R}$$

$$\text{Factor of Safety} = \frac{\text{ultimate load}}{\text{safe working load}} = \frac{\text{ultimate stress}}{\text{safe working stress}}$$

Young's Modulus and Stress

Material	Young's Modulus E kN/mm ²	Yield Stress σ_Y N/mm ²	Ultimate Tensile Stress N/mm ²	Ultimate Compressive Stress N/mm ²
Mild steel	196	220	430	430
Stainless steels	190–200	286–500	760–1280	460–540
Low-alloy steels	200–207	500–1980	680–2400	680–2400
Cast iron	120	—	120–160	600–900
Aluminium alloy	70	250	300	300
Soft brass	100	50	80	280
Cast bronze	120	150	300	—
Titanium alloy	110	950	1000	1000
Nickel alloys	130–234	200–1600	400–2000	400–2000
Concrete	—	—	—	60
Concrete (steel reinforced)	45–50	—	—	100
Concrete (post stressed)	—	—	—	100
Plastic, ABS polycarbonate	2·6	55	60	85
Plastic, polypropylene	0·9	19–36	33–36	70
Wood, parallel to grain	9–16	—	55–100	6–16
Wood, perpendicular to grain	0·6–1·0	—	—	2–6
Soda glass	69	3600	—	—
Diamond	1000	50 000	—	—
Gold	82	40	220	—
Ice	9·1	85	—	—

Bending of Beams

All beams of length L , second moment of area I , and Young's modulus E . Point C is located at mid-span.

ω = load per unit length (uniformly distributed load)

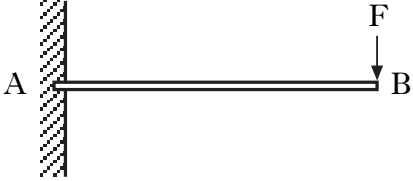
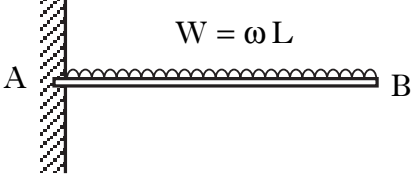
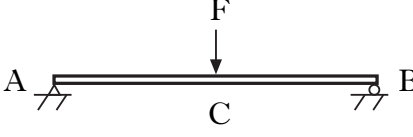
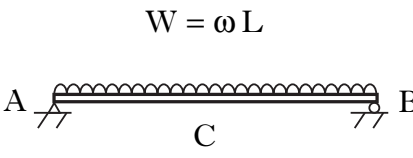
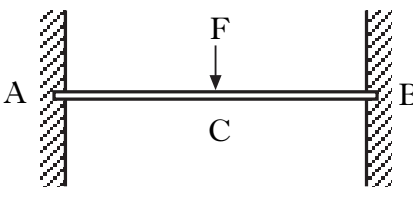
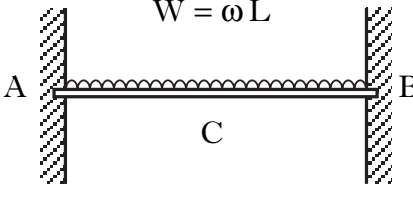
Configuration	Maximum Bending Moment	Maximum Deflection
	$= FL$ at A	$= \frac{FL^3}{3EI}$ at B
	$= \frac{\omega L^2}{2}$ at A	$= \frac{\omega L^4}{8EI}$ at B
	$= \frac{FL}{4}$ at C	$= \frac{FL^3}{48EI}$ at C
	$= \frac{\omega L^2}{8}$ at C	$= \frac{5\omega L^4}{384EI}$ at C
	$= \frac{FL}{8}$ at C $= -\frac{FL}{8}$ at A, B	$= \frac{FL^3}{192EI}$ at C
	$= \frac{\omega L^2}{24}$ at C $= -\frac{\omega L^2}{12}$ at A, B	$= \frac{\omega L^4}{384EI}$ at C

Second Moment of Area (I) of Common Sections

Rectangular

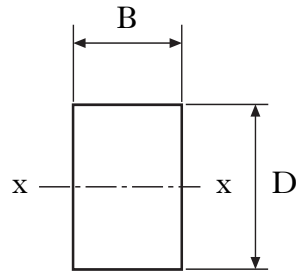

$$I_{xx} = \frac{BD^3}{12}$$

Circular

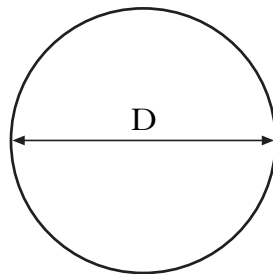

$$I = \frac{\pi D^4}{64}$$

Dimensions and Properties of Standard Sections

This information has been extracted from “Steel section tables” to illustrate the format used in such tables.

Dimensions and Properties of Square Hollow Sections

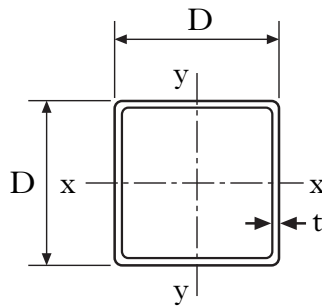

Designation		Second moment of area
Size $D \times D$	Thickness t	
mm	mm	($\times 10^4 \text{mm}^4$)
20 × 20	2.0	0.76
	2.6	0.88
30 × 30	2.6	3.49
	3.2	4.00
40 × 40	2.6	8.94
	3.2	10.40
	4.0	12.10
50 × 50	3.2	21.60
	4.0	25.50
	5.0	29.60
60 × 60	3.2	38.70
	4.0	46.10
	5.0	54.40

Dimensions and Properties of Rectangular Hollow Sections

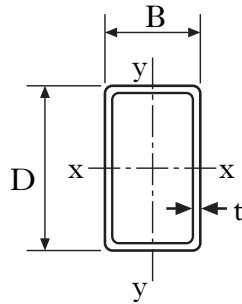

Designation		Second moment of area ($\times 10^4 \text{mm}^4$)	
Size $D \times B$	Thickness t		
mm	mm	Axis x-x	Axis y-y
50 × 30	2.6	12.40	5.45
	3.2	14.50	6.31
60 × 40	3.2	28.30	14.80
	4.0	33.60	17.30
80 × 40	3.2	58.10	19.10
	4.0	69.60	22.60
90 × 50	3.6	99.80	39.10
	5.0	130.00	50.00
100 × 50	3.2	117.00	39.10
	4.0	142.00	46.70
	5.0	170.00	55.10

Dimensions and Properties of Joists

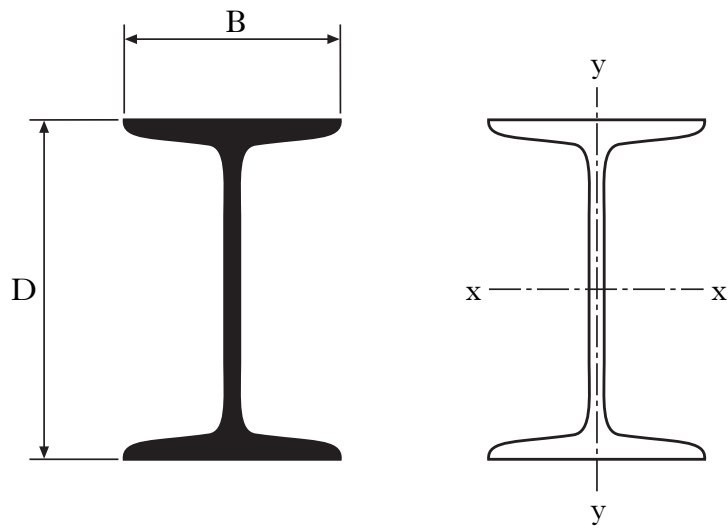

Depth of section (mm)	Breadth of section (mm)	Second moment of area ($\times 10^4 \text{mm}^4$)	
		Axis x-x	Axis y-y
D	B		
127	114	944.80	235.40
127	76	569.40	60.35
114	114	735.40	223.10
102	102	486.10	154.40
102	64	217.60	25.30
102	44	152.30	7.91
89	89	306.70	101.10
76	80	171.90	60.77
76	76	158.60	52.03



Customer Contact Centre

T: 0845 279 1000 E: customer@sqa.org.uk W: www.sqa.org.uk
BB4471 July 2008

ISBN: 978 1 85969 613 2