

FOR OFFICIAL USE

--	--	--	--	--	--

--

Total Marks

X069/101

NATIONAL
QUALIFICATIONS
2007

WEDNESDAY, 16 MAY
1.00 PM – 2.30 PM

PHYSICS
INTERMEDIATE 1

Fill in these boxes and read what is printed below.

Full name of centre

--

Town

--

Forename(s)

--

Surname

--

Date of birth

Day Month Year

--	--	--	--	--	--	--	--

Scottish candidate number

--	--	--	--	--	--	--	--	--	--

Number of seat

--

Reference may be made to the Physics Data Booklet.

Section A – Questions 1–20 (20 marks)

Instructions for completion of **Section A** are given on page two.

For this section of the examination you must use an **HB pencil**.

Section B (60 marks)

All questions should be attempted.

The questions may be answered in any order but all answers are to be written in the spaces provided in this answer book, **and must be written clearly and legibly in ink**.

Rough work, if any should be necessary, should be written in this book, and then scored through when the fair copy has been written. If further space is required, a supplementary sheet for rough work may be obtained from the invigilator.

Additional space for answers will be found at the end of the book. If further space is required, supplementary sheets may be obtained from the invigilator and should be inserted inside the **front** cover of this booklet.

Before leaving the examination room you must give this book to the invigilator. If you do not, you may lose all the marks for this paper.



SECTION A

- 1 Check that the answer sheet provided is for Physics Intermediate 1 (Section A).
- 2 For this section of the examination you must use an **HB pencil** and, where necessary, an eraser.
- 3 Check that the answer sheet you have been given has **your name, date of birth, SCN** (Scottish Candidate Number) and **Centre Name** printed on it.
Do not change any of these details.
- 4 If any of this information is wrong, tell the Invigilator immediately.
- 5 If this information is correct, **print** your name and seat number in the boxes provided.
- 6 The answer to each question is **either** A, B, C, D or E. Decide what your answer is, then, using your pencil, put a horizontal line in the space provided (see sample question below).
- 7 There is **only one correct** answer to each question.
- 8 Any rough working should be done on the question paper or the rough working sheet, **not** on your answer sheet.
- 9 At the end of the exam, put the **answer sheet for Section A inside the front cover of this answer book.**

Sample Question

The energy unit measured by the electricity meter in your home is the

- A kilowatt-hour
- B ampere
- C watt
- D coulomb
- E volt.

The correct answer is **A**—kilowatt-hour. The answer **A** has been clearly marked in **pencil** with a horizontal line (see below).



Changing an answer

If you decide to change your answer, carefully erase your first answer and, using your pencil, fill in the answer you want. The answer below has been changed to **E**.

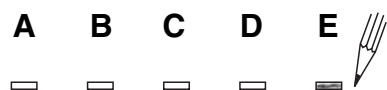

SECTION A

Answer questions 1–20 on the answer sheet.





1. On a colour television screen, which colours of light are mixed to produce magenta?
 - A Red and green
 - B Red and blue
 - C Blue and green
 - D Blue and yellow
 - E Blue, green and red

2. The unit of frequency is the
 - A decibel
 - B watt
 - C hertz
 - D volt
 - E second.

3. A student makes the following statements about optical fibres.
 - I Light travels in an optical fibre at a speed of nearly 200 000 000 metres per second.
 - II Optical fibres can be made from long, thin pieces of glass.
 - III Optical fibres carry electrical signals.Which of these statements is/are true?
 - A I only
 - B I and II only
 - C I and III only
 - D II and III only
 - E I, II and III

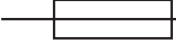
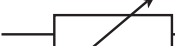
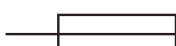
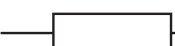
[Turn over

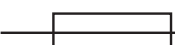
4. Which row in the table shows the symbols for a resistor and a variable resistor?

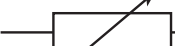
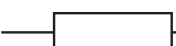
	<i>Resistor</i>	<i>Variable Resistor</i>
A		
B		
C		
D		
E		

5. A circuit is set up as shown.

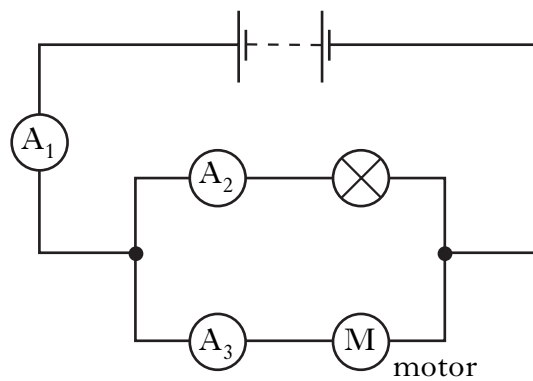

Which row in the table shows the possible readings on ammeters A_1 , A_2 and A_3 ?

	<i>Reading on A_1 in amperes</i>	<i>Reading on A_2 in amperes</i>	<i>Reading on A_3 in amperes</i>
A	1	2	3
B	1	3	2
C	3	3	3
D	5	2	3
E	6	2	3

6. Infrared radiation is used in medicine to
- A treat muscle injuries
 - B detect broken bones
 - C trace blood flow
 - D treat acne
 - E kill cancer cells.
7. Which of the following can be used to detect X-rays?
- A Photographic film
 - B Aerial
 - C Microphone
 - D Oscilloscope
 - E Continuity tester
8. Which of the following best describes a laser beam?
- A A narrow beam of white light
 - B A wide beam of white light
 - C A wide beam of red light
 - D A narrow beam of green light
 - E A wide beam of green light
9. Dogs can hear sounds with frequencies between 10 hertz and 30 000 hertz. Dogs and humans can both hear sounds with a frequency of
- A 10 hertz
 - B 15 hertz
 - C 1500 hertz
 - D 25 000 hertz
 - E 30 000 hertz.
10. A student carries out an experiment with a vibrating guitar string. Which of the following changes would produce the lowest frequency of sound?
- A Halving the length of the string
 - B Doubling the length of the string
 - C Keeping the length the same and tightening the string
 - D Halving the length of the string and tightening the string
 - E Doubling the length of the string and tightening the string

[Turn over

11. A student is 1500 metres from a fireworks display.
He hears the bang from an exploding firework 5 seconds after seeing the flash.
Using these figures, the student calculates the speed of sound in air to be
- A 5 metres per second
 - B 300 metres per second
 - C 340 metres per second
 - D 1500 metres per second
 - E 7500 metres per second.

12. An alarm clock is inside a jar as shown.

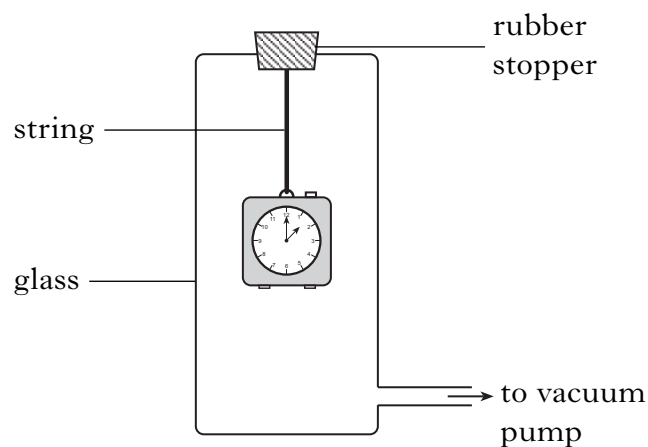

The sound from the alarm is heard clearly.
All of the air in the jar is now pumped out.
The alarm cannot be heard because

- A sound cannot pass through string
 - B sound cannot pass through a vacuum
 - C sound cannot pass through glass
 - D sound cannot pass through air
 - E sound cannot pass through rubber.
13. A CD player contains an amplifier.
The amplifier is used to
- A increase the frequency of an electrical signal
 - B decrease the frequency of an electrical signal
 - C change sound into electrical energy
 - D change electrical energy into sound
 - E increase the amplitude of an electrical signal.

14. Five cars are acted on by different forces.
Which of the cars is speeding up to the right?

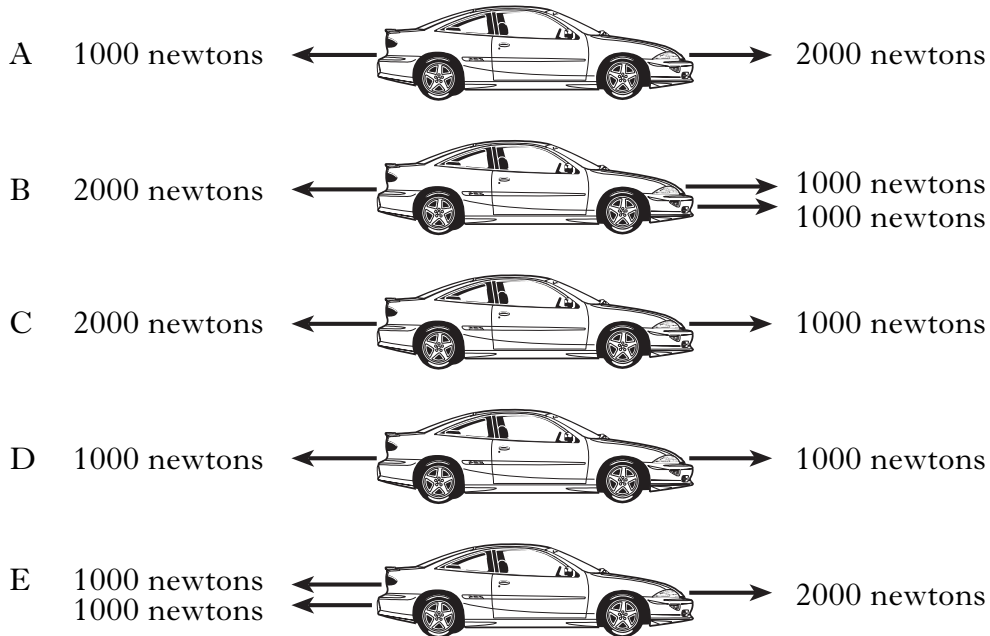

15. A car moves along a straight road in the direction shown.

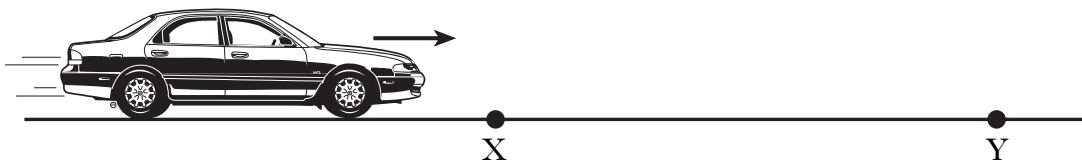

The distance between X and Y is measured.

The only other measurement needed to calculate the average speed of the car between X and Y is

- A the speed of the car at X
- B the speed of the car at Y
- C the acceleration of the car between X and Y
- D the time for the car to travel from X to Y
- E the length of the car.

[Turn over

16. Sportsmen and sportswomen use a variety of methods to increase or decrease the force of friction.
- Which of the following statements describes a method used to increase the force of friction?
- A A cyclist oiling the chain of her bicycle
 - B An athlete wearing smooth, tight-fitting clothing
 - C A swimmer wearing a swimming cap
 - D A weightlifter chalking his hands
 - E A skier waxing her skis

17. A ball is dropped onto a surface.

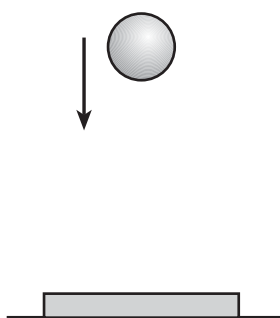

A student makes the following statements about the height to which the ball rebounds.

- I The height is affected by the material of the ball.
- II The height is affected by the material of the surface.
- III The height is affected by the speed the ball hits the surface.

Which of these statements is/are true?

- A III only
 - B I and II only
 - C I and III only
 - D II and III only
 - E I, II and III
18. Which one of the following devices is used to convert electrical energy into other forms of energy?
- A Switch
 - B LDR
 - C Microphone
 - D Motor
 - E Thermistor

19. The block diagram for a security light system is shown.

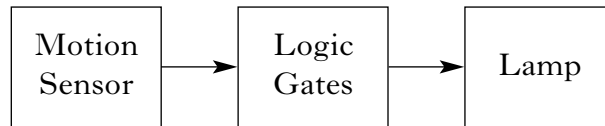

Which row in the table shows the input, process and output for this system?

	<i>Input</i>	<i>Process</i>	<i>Output</i>
A	Logic gates	Motion sensor	Lamp
B	Logic gates	Lamp	Motion sensor
C	Lamp	Logic gates	Motion sensor
D	Motion sensor	Lamp	Logic gates
E	Motion sensor	Logic gates	Lamp

20. Input and output devices are used in electronics.

Which row in the table is correct?

	<i>Input device</i>	<i>Output device</i>
A	LED	buzzer
B	microphone	LDR
C	loudspeaker	microphone
D	switch	microphone
E	LDR	motor

Candidates are reminded that the answer sheet for Section A MUST be placed INSIDE the front cover of this answer book.

[Turn over for Section B

Marks

SECTION B

Answer questions 21–31 in the spaces provided.

21. Mobile phones are used by many people today.

(a) From the list below, circle the type of signal used by mobile phones to send and receive phone calls.

Gamma

X-Rays

Ultraviolet

Visible Light

Infrared

Radio & TV

1

(b) Name the device used in a mobile phone to change sound energy into electrical energy.

1

(c) (i) Name the device used in a mobile phone that produces sound.

1

(ii) What must this device do to produce sound?

1

21. (continued)

Marks

- (d) In an experiment to investigate mobile phone signals, a student sets up the following equipment. The mobile phone transmits signals as pulses.

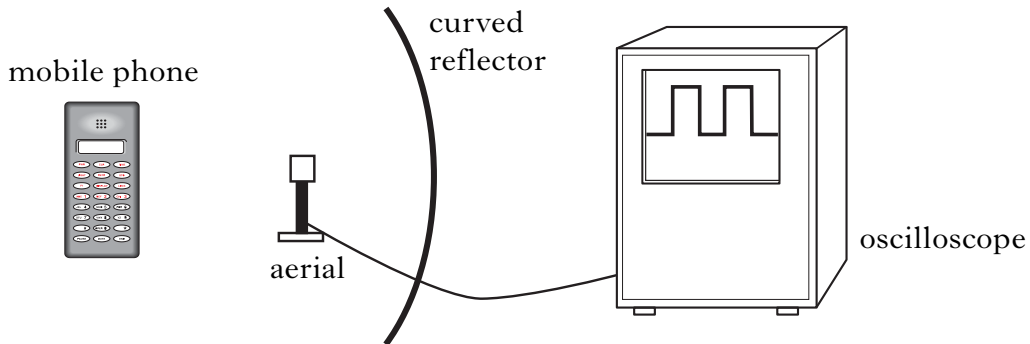

- (i) Why is there a curved reflector behind the aerial?

1

- (ii) Complete the diagram below to show how the curved reflector affects the signals. On your diagram, mark where the aerial should be positioned to get the strongest signal.

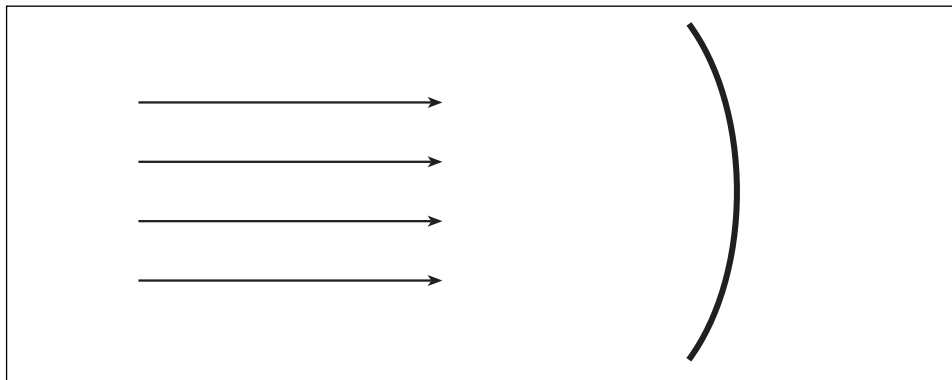

2

- (iii) On the blank oscilloscope grid below, draw the signal that you would expect to see if the curved reflector was removed.

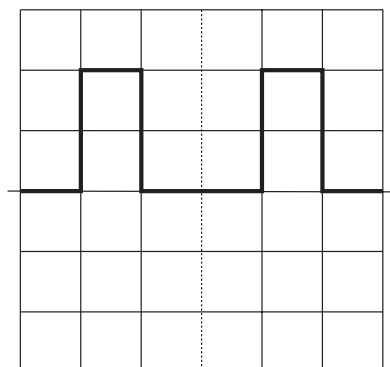

Signal received when a curved reflector is used.

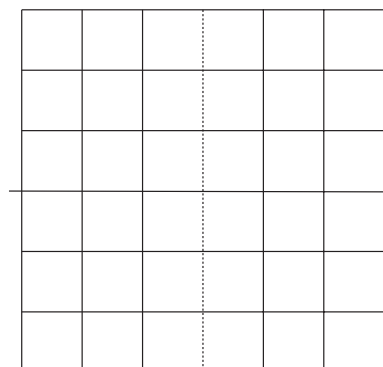

Signal received with curved reflector removed.

2

Marks

22. Cars have many different electric circuits.

(a) This circuit shows how the headlights are connected.

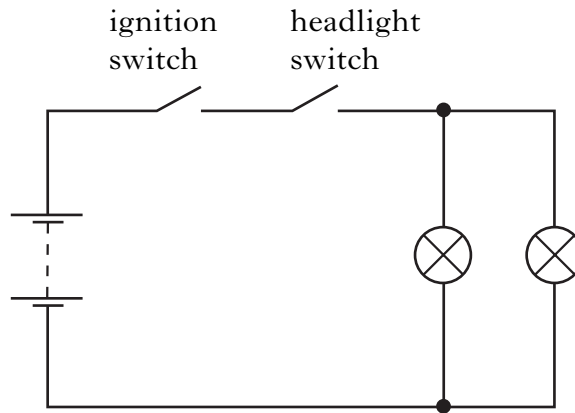

(i) Are the switches connected in series or parallel?

1

(ii) Give a reason why the switches are connected in this way.

1

(iii) When the headlights are operating normally, the current in each lamp is 4.5 amperes.

What is the current from the battery when the headlights operate normally?

1

Marks

22. (continued)

- (b) This circuit diagram shows how the windscreen wiper motor is connected.

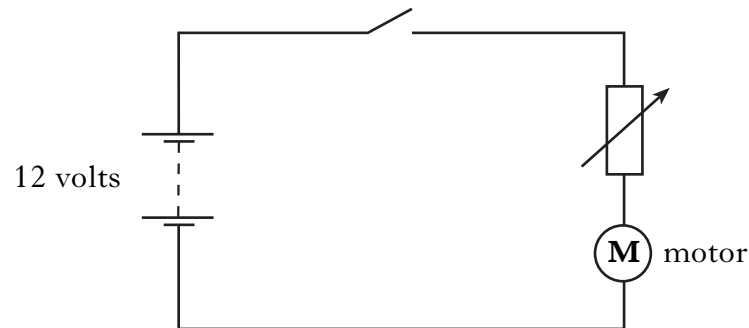

- (i) When the switch is closed, the voltage across the variable resistor is 2.4 volts. What is the voltage across the motor?

1

- (ii) The current in the variable resistor is 0.6 amperes. Calculate the resistance of the variable resistor.

2

- (iii) The resistance of the variable resistor is increased.

- (A) What will happen to the speed of the motor?

1

- (B) Explain your answer.

1

Marks

23. A football match is broadcast live on television.

Some viewers are watching the match in a house 1 kilometre away from the stadium.

(a) A goal is scored and the viewers first hear the crowd on the television and then hear the crowd from the stadium.

Explain why there is a delay.

1

(b) Complete the block diagram below showing the main parts of a television.

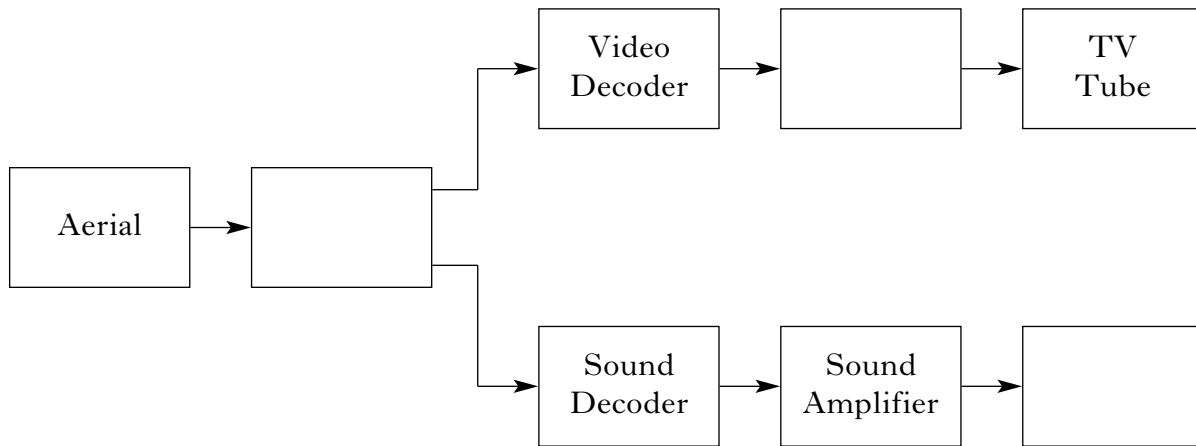

3

Marks

24. A student made a telescope to look at distant objects.
The telescope has 2 lenses called the objective and eyepiece.

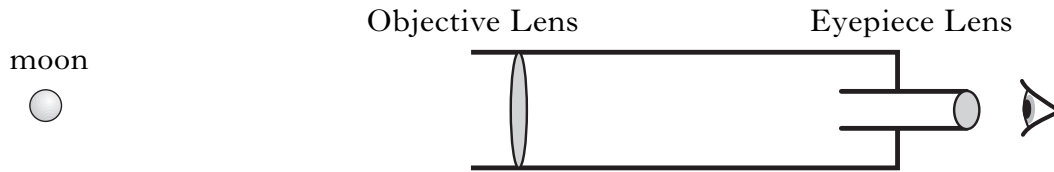

The table below gives information about the lenses.

Name	Diameter	Thickness	Purpose
Objective	Large	Thin	Collect light
Eyepiece	Small	Thick	Magnify

- (a) Looking at the diagram, name the **type of lens** used as the objective.

1

- (b) The student now looks through the telescope from the other end.

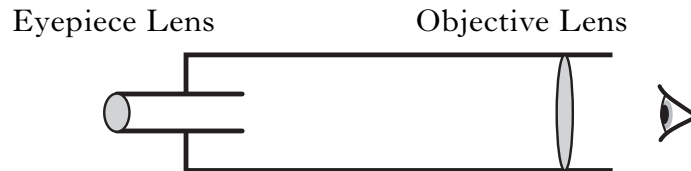

- (i) Would the image now be **brighter**, **less bright** or the **same brightness** than the image he first saw in part (a)?

Explain your answer.

2

- (ii) Would the image be **larger**, **smaller** or the **same size** than the image he first saw in part (a)?

Explain your answer.

2

Marks

25. Table 1 lists some uses of different types of radiation.

Table 1

	<i>Use</i>
A	Detected by the eye
B	Check luggage at airports
C	Control model cars
D	Grill food
E	Kills cancer cells
F	Gives a suntan

Complete Table 2 using the letters A, B, C, D, E and F, to match each radiation with its use.

You should use each letter **once** only.

Table 2

<i>Radiation</i>	
Gamma	
X-Rays	
Ultra-Violet	
Visible Light	
Infra Red	
Radio waves	

3

Marks

26. The diagram shows rays of light entering an eye of someone with **normal vision**.

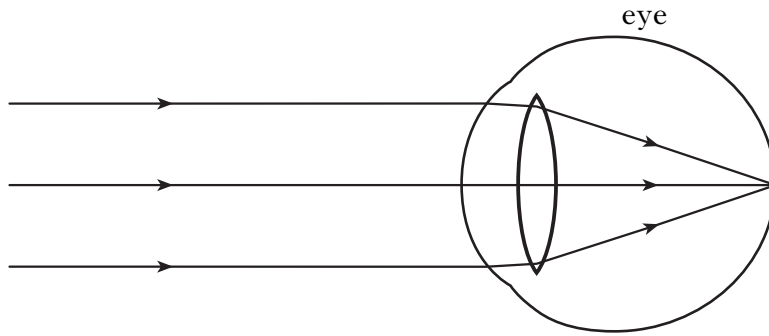

(a) (i) Complete the diagram below to show how rays of light from a **distant object** enter the eye of someone with **short sight**.

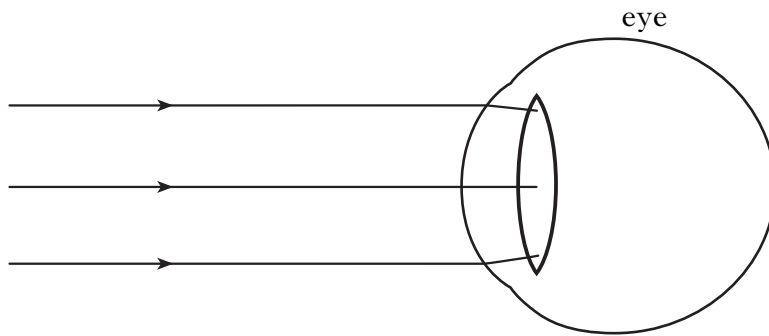

1

(ii) Complete the diagram below to show how rays of light from a **near object** enter the eye of someone with **short sight**.

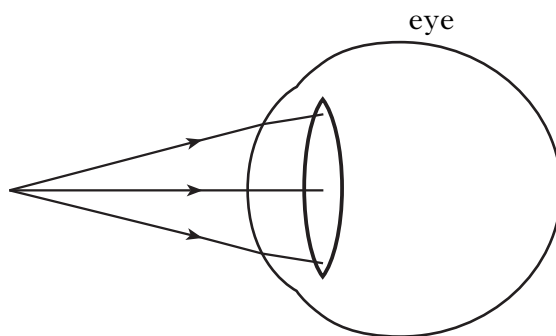

1

(b) Name the type of lens used to correct short sight.

1

[Turn over

Marks

27. Some boats use sound waves to find the depth of the sea.

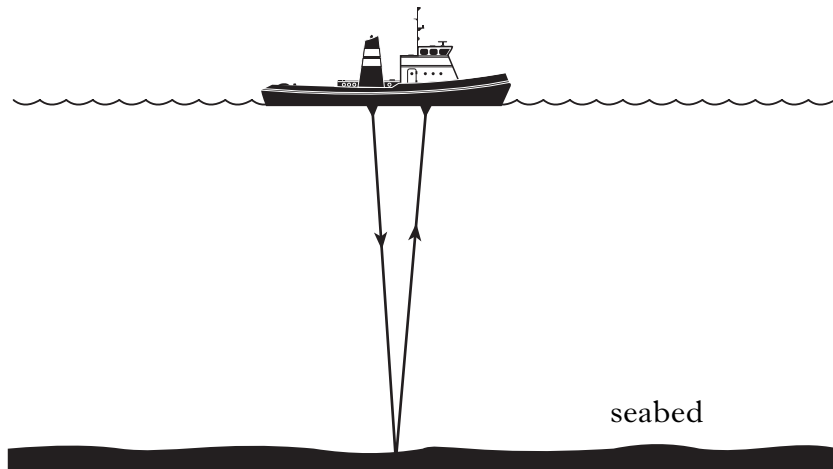

- (a) Sound waves are sent out by a device on the bottom of the boat. They are detected after reflecting off the seabed. In the passage below, circle the correct words.

Sound waves are sent out by a

transmitter/receiver

and picked up by a

transmitter/receiver

1

Marks

27. (continued)

- (b) An oscilloscope screen on the boat shows the sound signal being sent out and detected after reflecting off the seabed.

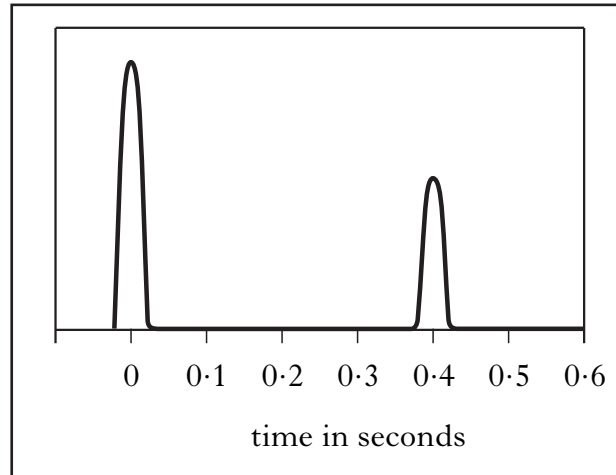

- (i) Explain why the reflected signal has a smaller height than the signal sent out.

1

- (ii) Look at the oscilloscope trace.
What is the time taken for the sound signal to reach the seabed?

1

- (iii) The depth of the sea is 306 metres. Use your answer to part (ii) to calculate the speed of sound in the water.

2

[Turn over

Marks

28. A skydiver jumps out of a plane.



- (a) The skydiver and her parachute have a total mass of 75 kilograms. Calculate the total weight of the skydiver and parachute.

2

- (b) When she first leaves the plane, the skydiver accelerates towards the earth.

What does the term accelerate mean?

1

- (c) The diagram below shows the skydiver and the forces acting on her.

- (i) Name the **two** vertical forces acting on the skydiver.

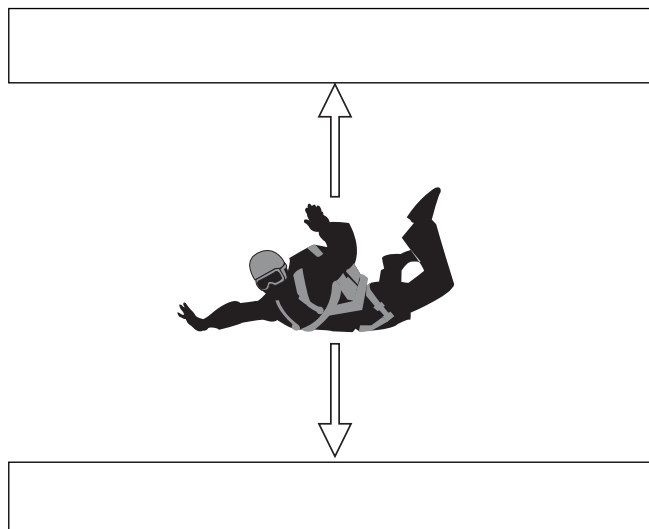

2

Marks

28. (c) (continued)

(ii) Some time later these two forces become balanced.

When the forces are balanced, does her speed **increase**, **stay the same** or **decrease**?

1

(d) The skydiver then opens her parachute.

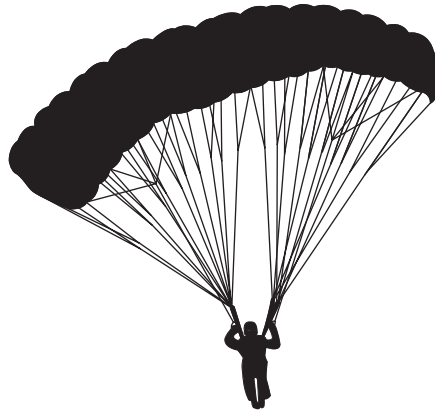

(i) What happens to her speed at this moment?

1

(ii) What happens to the upward force acting on her?

1

[Turn over

Marks

29. A student playing pool knows that when the cue ball hits a cushion it obeys the same rule as light reflecting off a mirror.

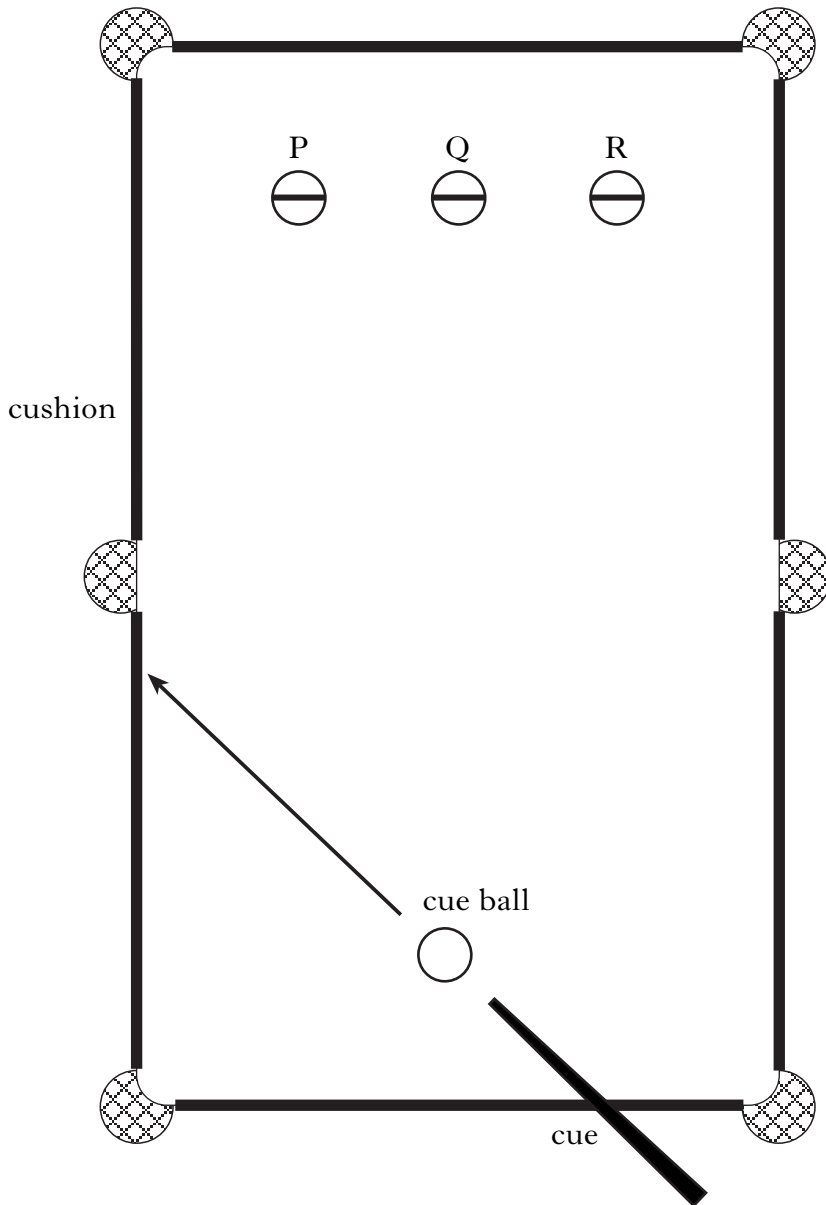

- (a) Using this information, state which ball she will hit.

1

Marks

29. (continued)

(b) Her friend wants to know how fast the cue ball moves immediately after it has been struck. They use a light gate, an electronic timer and a ruler.

Describe how this equipment would be used to find the speed of the ball immediately after it has been struck.

Your description should include:

- the measurements taken
- how these measurements would be used to calculate the instantaneous speed.

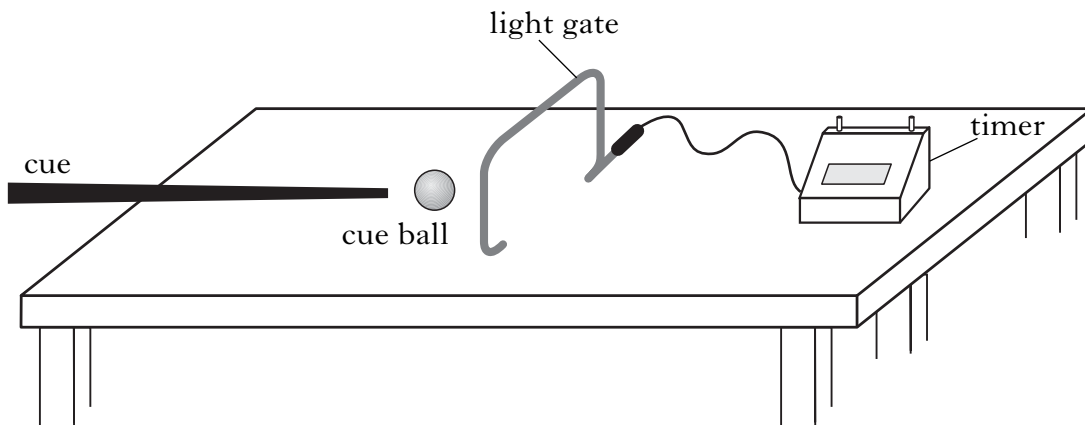

2

[Turn over

Marks

30. A museum has a statue on display. A security system is in place to protect the statue.

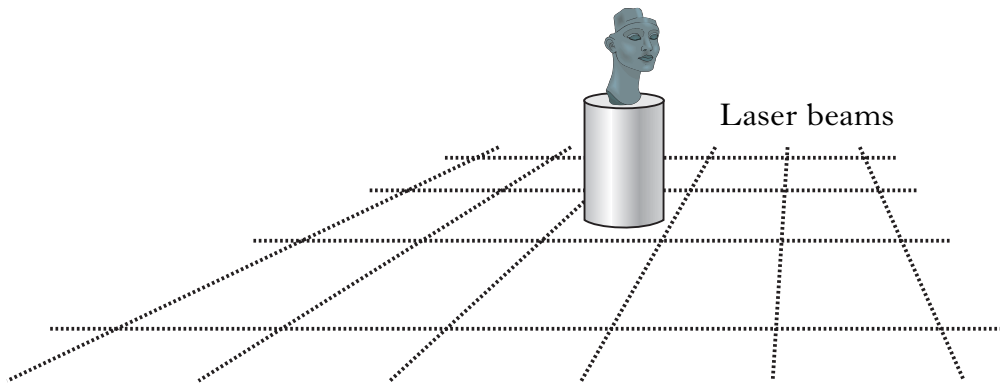

- (a) The system uses laser beams which will sound an alarm if broken.
The diagram of the laser alarm system is shown below.
The system is activated by a master switch.

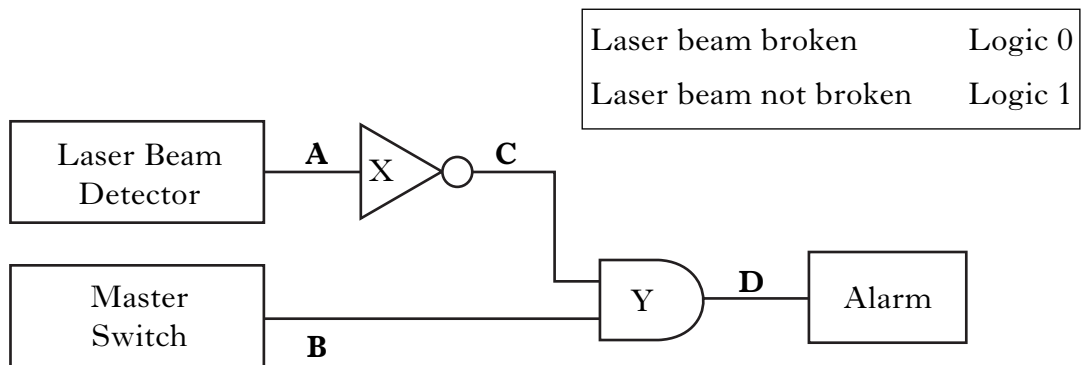

- (i) Name logic gate Y.

1

- (ii) Complete the table below to show the logic levels at **C** and **D**.

A	B	C	D
0	0		
0	1		
1	0		
1	1		

2

Marks

30. (continued)

(b) To improve security, the statue is placed on a pressure pad.

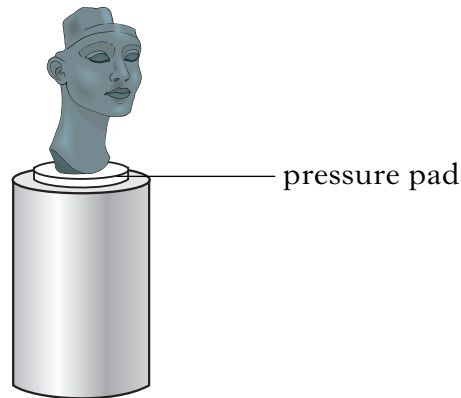

If the statue is lifted from the pressure pad, a small voltage is produced. This voltage has to be amplified to operate the alarm.



(i) Calculate the voltage gain of the amplifier.

2

(ii) The power rating of the alarm is 14 W.
Calculate the current in the alarm when it operates.

2

[Turn over

Marks

31. Washing machines use thermistors as temperature sensors.

(a) Is a thermistor an **input**, **process** or an **output** device?

1

(b) A student wants to check that a washing machine thermistor is working correctly. He sets up the following experiment.

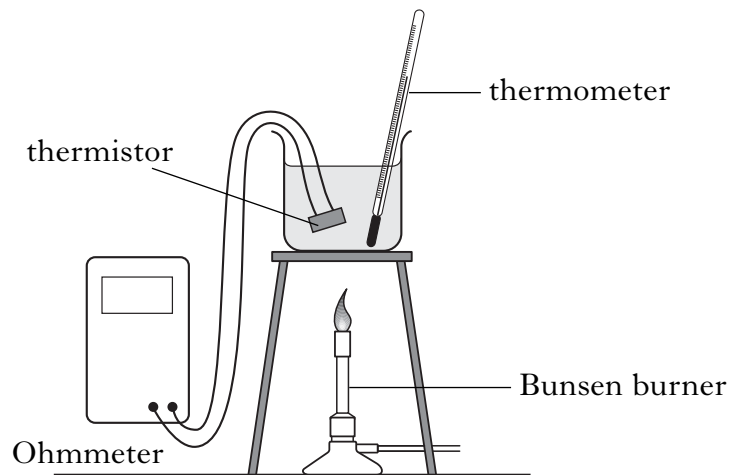

Explain how he should use the equipment to investigate how the resistance of the thermistor is affected by temperature.

Your answer should include:

- how he used the equipment
- what he measured.

2

Marks

31. (continued)

(c) After the experiment, the student plotted the following graph.

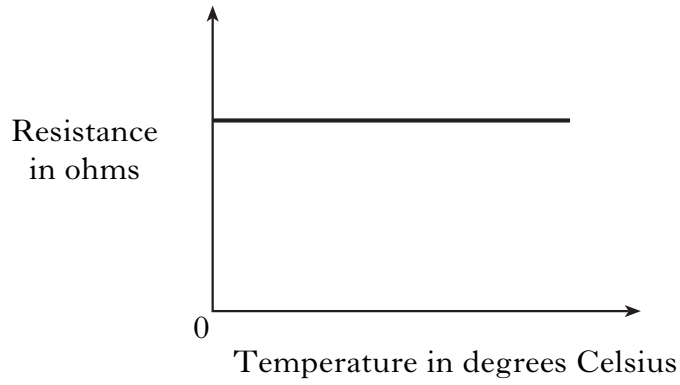

(i) Was the thermistor working correctly?

1

(ii) Explain your answer.

1

[END OF QUESTION PAPER]

Marks

YOU MAY USE THE SPACE ON THIS PAGE TO REWRITE ANY ANSWER YOU HAVE DECIDED TO CHANGE IN THE MAIN PART OF THE ANSWER BOOKLET. TAKE CARE TO WRITE IN CAREFULLY THE APPROPRIATE QUESTION NUMBER.