



# Requesting Adapted or Digital Question Papers: Guidance for Centres

Publication date: October 2023

Publication code: BB 7579

Published by the Scottish Qualifications Authority  
The Optima Building, 58 Robertson Street, Glasgow G2 8DQ  
Lowden, 24 Wester Shawfair, Dalkeith, EH22 1FD

[www.sqa.org.uk](http://www.sqa.org.uk)

The information in this publication may be reproduced in support of SQA qualifications. If it is reproduced, SQA should be clearly acknowledged as the source. If it is to be used for any other purpose, written permission must be obtained from SQA. It must not be reproduced for trade or commercial purposes.

© Scottish Qualifications Authority 2023

# Adapted question paper terminology guide

An adapted question paper is a bespoke question paper that is adapted to best suit the requirements of each individual candidate and assist them when sitting examinations. The current adaptations offered include **adapted print**, **braille**, **coloured paper**, **modified content** and **optionality**. Examples of some of these adaptations are provided in this guidance, where possible. As each adapted question paper is produced on request for a specific candidate's exam each year, we cannot guarantee that past paper examples are available with the specific adaptations your candidate may require.

You can request the following types of adapted question papers from us using the Assessment Arrangements Request (AAR) system. Please also refer to the AAR system user guide, which you can find on SQA Secure under NQ then Assessment Arrangements.

Adapted question papers include:

1. Digital question papers
2. Question papers printed on a specified colour
3. Standard large print question papers
4. Adapted print question papers
5. Modified large print question papers
6. Brailled question papers
7. Question papers modified as for braille
8. Print Copy of Braille (PCB)
9. Optionality

The terminology above is explained in Section 1 below, against the corresponding number.

You can also request the following adaptations using the AAR system:

10. Adapted, enlarged/proportionately enlarged artwork
11. Simplified artwork (where possible)
12. No artwork
13. Question paper with colour-indicating arrows (for candidates with colour blindness)
14. Tactile diagrams with braille or print labels
15. Diagrams with greyscaling/shading removed
16. Double line spacing
17. Bold font
18. Enlarged geography maps
19. Other arrangement
20. Additional comments

## Contents

**Section 1** - Adapted Question Papers

**Section 2** - Font Size and double line spacing

**Section 3** - Artwork Examples

**Section 4** - SQA Glossary

**Section 5** - Frequently asked questions

You must submit your requests for adapted question papers using the AAR system before the production deadline date of **31 January 2024**.

Requests for adapted and digital coursework for Administration and IT and Accounting must be submitted by **20 December 2023**.

# Section 1

## 1. Digital question papers

This is a direct replica of the mainstream question paper supplied as a PDF for on-screen display and, where appropriate, completion. SQA does not adapt or modify a digital question paper in any way but learners can adjust screen colours or change the size of the text to suit individual requirements. For this reason, a digital question paper cannot be used as a digital reader if an adapted or modified question paper has been requested.

You must read the guidance on digital question papers on the Digital Question Papers' webpage at <http://www.sqa.org.uk/sqa/digitalquestionpapers>. To ensure full functionality of DQPs, it is essential that the relevant software must be up to date.

When a digital question paper is requested, AAR automatically populates the **Separate Accommodation** and **Use of ICT with spellchecker** options.

## 2. Question paper printed on a specified colour

SQA question papers are printed on white paper and can be printed on coloured paper for an assessment arrangement. SQA can only supply the seven standard colours shown below from the Kaskad paper range.

Any colour outwith this range must be supplied by the centre, in A3, to allow the same booklet format as the mainstream copy. You must contact the Assessment Arrangements team on 0345 213 6890 and confirm that you will supply SQA with your required coloured paper in A3 size.



Please note that answer books are not available in adapted format. They are only provided in the standard A4 booklet format in white, or in the colour that has been approved for the corresponding question paper.

Where question papers contain colour images (Art and Design, Design and Manufacture, Environmental Science, Fashion and Textile Technology, Graphic Communication, Media and Photography) coloured question papers will be printed in black and white. Candidates must refer to the question paper from the main supply to access the colour images.

Candidates can also choose to use the colour overlay they use in teaching and learning in the exam without requesting this with SQA.

## Section 1 (continued)

### 3. Standard large print question papers

This is the original question paper enlarged to 18pt, in standard SQA font, on A3 white paper or one of the colours shown on page 3.

### 4. Adapted print question papers

This is the original question paper produced in one of the following

Font sizes 14pt, 18pt, 24pt, 36pt and 48pt.

Font styles Standard SQA (Trebuchet), Arial, Comic Sans, OpenDyslexic

with **single** or **double** line spacing.

### 5. Modified large print question papers

This is the question paper produced in print using any of the above font sizes and/or font styles, in either portrait or landscape orientation. This can be requested for A4 and A3 paper and with any visual content simplified or removed to ensure it is accessible.

The question paper is modified in a way that ensures that the same skills, knowledge and understanding are assessed as in the original paper and that it is of an equivalent level of difficulty.

This question paper is available to select using the drop down options.

### 6. Brailled question paper

This is the question paper produced in braille with the layout and presentation of the standard print question paper appropriately modified for braille. This means that:

- visual content may be removed or replaced by tactile diagrams and graphs.
- questions may be appropriately modified.

A print copy of the braille (PCB) question paper will be supplied for use by a sighted reader.

### 7. Modified as for braille papers

This is the question paper modified in a way that ensures that the same skills, knowledge and understanding are assessed as in the original paper and that it is of an equivalent level of difficulty.

This question paper can also be requested in the standard font and size options listed in part 4.

A print copy of the braille (PCB) question paper will be supplied for use by a sighted reader.

### 8. Print Copy of Braille (PCB)

This is the printed version of the braille question paper. A text version of a braille paper with modifications of a braille question paper. To request a PCB, in AAR request a braille question paper with a comment in additional comments stating that a PCB version is required.

A print copy of the braille (PCB) question paper will be supplied for use by a sighted reader.

## Section 1 (continued)

### 9. Optionality

Optionality can be requested for the following subjects: History; Modern Studies; and Religious, Moral and Philosophical Studies.

While optionality can also be requested for English for learners with enlarged or braille question papers, this reduces the questions available to the learner. In these instances, you must have consent from the learner (and their parent/carer where required) to request this type of adaptation.

Selecting specific options for adapted papers can be done within the Assessment Arrangement Request system (AAR)

In the adapted paper tab tick 'Optionality'

Select 'Part' if you wish to only include the study contexts your candidate has studied in the academic year. Then note the study contexts in the 'Details' box.

If the full question paper is required (with all available contexts modified), please select 'All' and insert 'Full Question Paper required' into the 'Details' box.

Difficulties & Certs	Adapted Paper	Arrangements 1	Arrangements 2	Additional
Adapted Paper	<input checked="" type="checkbox"/>			
Adapted Print	<input type="checkbox"/>			
Braille	<input type="checkbox"/>			
Coloured Paper	<input type="checkbox"/>			
Modified Contents	<input type="checkbox"/>			
Optionality	<input checked="" type="checkbox"/>	Please Select	Part	Details
Digital Question Paper	<input type="checkbox"/>			

### 10. Adapted, enlarged/proportionately enlarged artwork

These are question papers where size of graphs, diagrams and photographs are increased. Where a request is made for font size to be enlarged, graphs, diagrams and photographs will be proportionally enlarged. Depending on the question paper content in the mainstream paper, for example graphics size, page orientation and paper size may differ from the requested font size, page size and orientation.

Please see enlarged artwork samples starting on page 16.

### 11. Simplified artwork (where possible)

These are question papers where images are removed or diagrams 'de-cluttered', for example removing finer graph background lines. Diagrams will only be removed or de-cluttered where they are not critical to the question/answer'.

### 12. No artwork

These are question papers where all artwork is removed.

## Section 1 (continued)

### 13. Question paper with colour-indicating arrows

This adaptation is only available for question papers that contain diagrams or images in colour. Colour-indicating arrows are printed directly onto question papers where colour content is key to a particular question. Colour indicating arrows are available for the following subjects: Art and Design, Design and Manufacture, Engineering Science, Graphic Communication, Health and Food Technology, Media, Photography. It is not always possible to indicate all colours in images. Only main colours are indicated.

Note: Geography OS Maps cannot be provided with colour indicating arrows.

### 14. Tactile diagrams with braille or print labels

Raised/tactile diagrams can be requested with 'braille' or with 'print' labels.

The print labels can also be requested in the font and sizes listed on page 4.

### 15. Diagrams with greyscaling/shading removed

These are question papers with all or some shading within diagrams removed when requested, if possible.

### 16. Double line spacing

These are question papers with double line spacing. This is the only alternative to single line spacing we provide.

Double line spacing relates to the spacing between lines of text and graphics within an adapted Question Paper.

Please note that double line spacing will double the page extent of an Adapted Question Paper request. Please consider any increase in font size requested with double line spacing.

### 17. Bold font

Question papers replicated in bold font. Bold text in mainstream paper will be underlined in a bold font request.

### 18. Enlarged Geography Maps

Ordnance Survey maps for learners with requests for font size 16pt and above, are provided at one standard enlargement at 150% and will be included in the blue adapted QP packet. All other candidates must use the OS Map from the main supply.

### 19. Other arrangements

'Other arrangements' section should be used for additional software information.

### 20. Additional comments

'Additional comments' section should be used for 'sitting at' information, where the accommodating centre is different to the presenting centre.

## Section 2

### Font and Size Examples

In the examples below, the impact of font size on increasing the number of pages on A4 paper page extent is shown and can be summarised as follows:

11pt - 9 lines, approx.  $\frac{1}{4}$  page (Standard SQA font (Trebuchet))

14pt – 10 lines, approx.  $\frac{1}{4}$  page

18pt – 12 lines, approx.  $\frac{1}{2}$  page

24pt – 16 lines, approx. 1 page

36pt – 27 lines, approx. 1.5 pages

48pt – 37 lines, approx. 3 pages

See also p26 for impact of font size on page extents.

### 11 pt SQA Standard Text. (11pt is standard font size)

#### On the spot

If you throw a rat into the middle of a room full of humans, it will instinctively freeze. By becoming completely still, it is more likely to avoid detection. Then, it will dart into a corner of the room, hoping to flee danger. If cornered, however, it will fight. Ferociously.

- 5 Psychologists call it the fight-flight-freeze response, and it emerged very early in evolution. We know this because it is common to all vertebrates. The response starts in a part of the brain which reacts when an animal is confronted by a threat, and is controlled by the automatic nervous system. This is the same system that manages digestion and respiration, and is independent of conscious will.

## Section 2 (continued)

14 pt Standard Text.

### On the spot

If you throw a rat into the middle of a room full of humans, it will instinctively freeze. By becoming completely still, it is more likely to avoid detection. Then, it will dart into a corner of the room, hoping to flee danger. If cornered, however, it will fight. Ferociously.

- 5 Psychologists call it the fight-flight-freeze response, and it emerged very early in evolution. We know this because it is common to all vertebrates. The response starts in a part of the brain which reacts when an animal is confronted by a threat, and is controlled by the automatic nervous system. This is the same system that manages
- 10 digestion and respiration, and is independent of conscious will.



## Section 2 (continued)

18 pt Standard Text.

### On the spot

If you throw a rat into the middle of a room full of humans, it will instinctively freeze. By becoming completely still, it is more likely to avoid detection. Then, it will dart into a corner of the room, hoping to flee  
5 danger. If cornered, however, it will fight. Ferociously. Psychologists call it the fight-flight-freeze response, and it emerged very early in evolution. We know this because it is common to all vertebrates. The response starts in a part of the brain which reacts when an animal is confronted by  
10 a threat, and is controlled by the automatic nervous system. This is the same system that manages digestion and respiration, and is independent of conscious will.

## Section 2 (continued)

24 pt Standard Text.

### On the spot

If you throw a rat into the middle of a room full of humans, it will instinctively freeze. By becoming completely still, it is more likely to avoid detection. Then, it will dart into a  
5 corner of the room, hoping to flee danger. If cornered, however, it will fight. Ferociously. Psychologists call it the fight-flight-freeze response, and it emerged very early in evolution. We know this because it is  
10 common to all vertebrates. The response starts in a part of the brain which reacts when an animal is confronted by a threat, and is controlled by the automatic nervous system. This is the same system that  
15 manages digestion and respiration, and is independent of conscious will.

## On the spot

If you throw a rat into the middle of a room full of humans, it will instinctively freeze. By becoming  
5 completely still, it is more likely to avoid detection. Then, it will dart into a corner of the room, hoping to flee danger. If cornered,  
10 however, it will fight. Ferociously.

Psychologists call it the fight-flight-freeze response, and it emerged very early in

## On the spot

If you throw a rat into the middle of a room full of humans, it will instinctively freeze. By 5 becoming completely still, it is more likely to avoid detection. Then, it will dart into a corner of the room, 10 hoping to flee danger.

## Section 2 (continued)

### Example of Double line spacing

12 pt Arial Text.

#### On the spot

If you throw a rat into the middle of a room full of humans, it will instinctively freeze. By becoming completely still, it is more likely to avoid detection. Then, it will dart into a corner of the room, hoping to flee danger. If cornered, however, it will fight. Ferociously.

Psychologists call it the fight-flight-freeze response, and it emerged very early in evolution.

- 5 We know this because it is common to all vertebrates. The response starts in a part of the brain which reacts when an animal is confronted by a threat, and is controlled by the automatic nervous system. This is the same system that manages digestion and respiration, and is independent of conscious will.

12 pt Arial Text Double Line Spacing Text.

#### On the spot

If you throw a rat into the middle of a room full of humans, it will instinctively freeze. By becoming completely still, it is more likely to avoid detection. Then, it will dart into a corner of the room, hoping to flee danger. If cornered, however, it will fight. Ferociously.

Psychologists call it the fight-flight-freeze response, and it emerged very early in evolution.

- 5 We know this because it is common to all vertebrates. The response starts in a part of the brain which reacts when an animal is confronted by a threat, and is controlled by the automatic nervous system. This is the same system that manages digestion and respiration, and is independent of conscious will.

## Section 2 (continued)

36 pt Arial Text.

### On the spot

If you throw a rat into the middle of a room full of humans, it will instinctively freeze. By becoming  
5 completely still, it is more likely to avoid detection. Then, it will dart into a corner of the room, hoping to flee danger. If cornered,  
10 however, it will fight. Ferociously.

## Section 2 (continued)

36 pt Arial Double Line Spacing Text.

# On the spot

If you throw a rat into the middle of a room full of humans, it will instinctively freeze. By becoming  
5 completely still, it is more likely to avoid detection.

# Section 3 Artwork Examples

Original Artwork

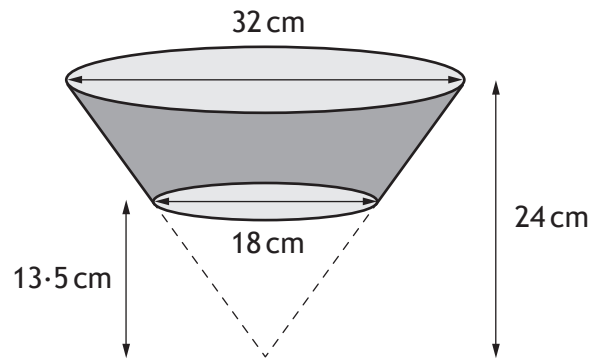

14pt Artwork

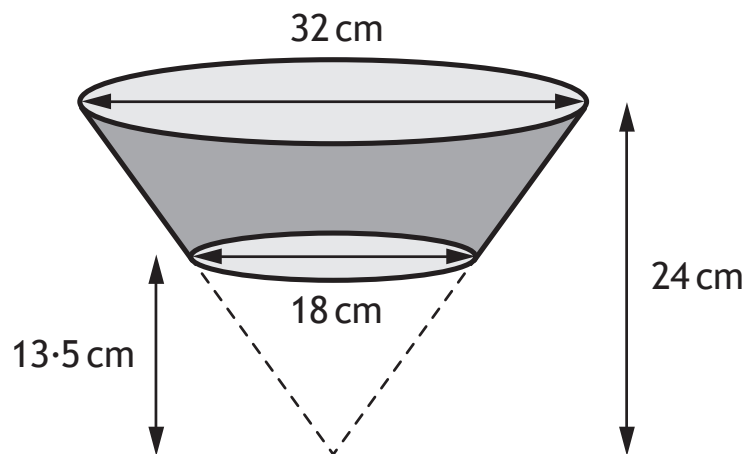



### Section 3 Artwork Examples (continued)

18pt Artwork

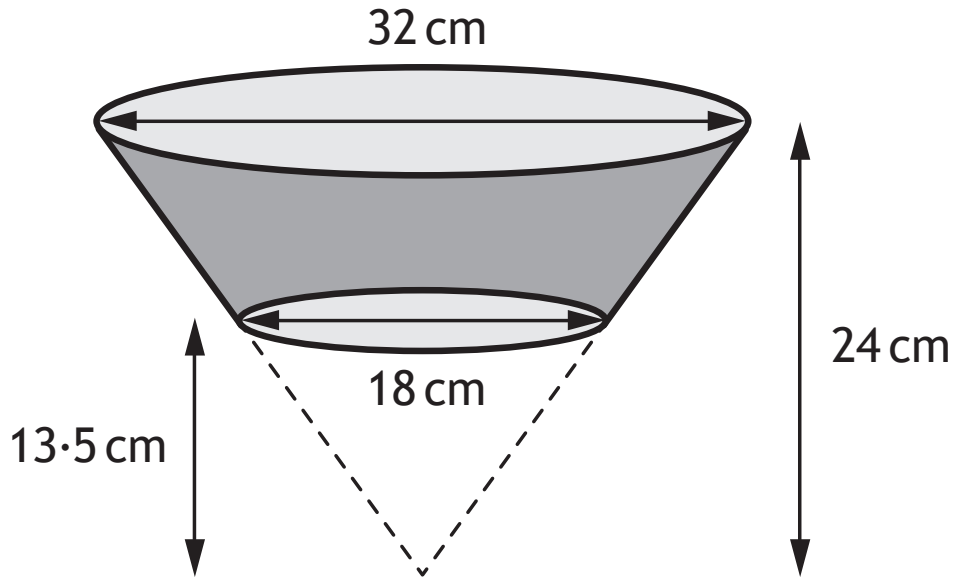

24pt Artwork

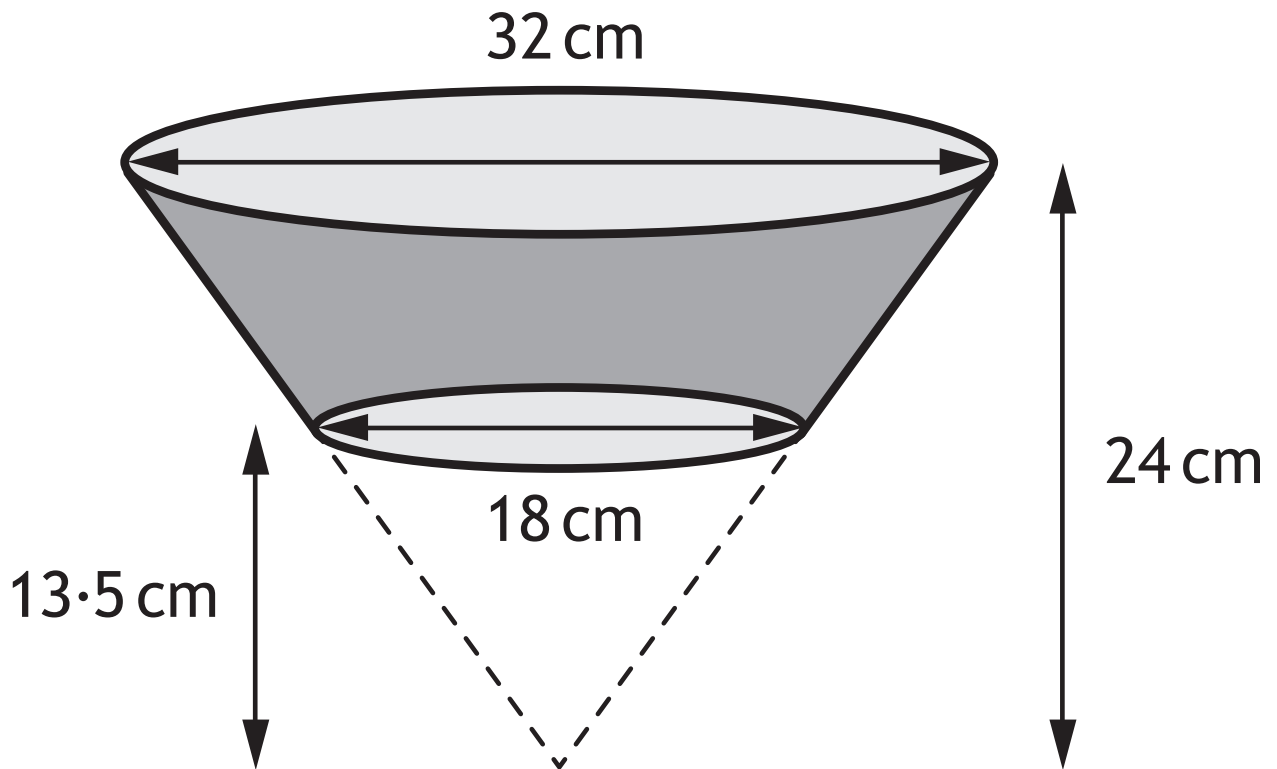

**Section 3 Artwork Examples (continued)**

36pt Artwork

32 cm

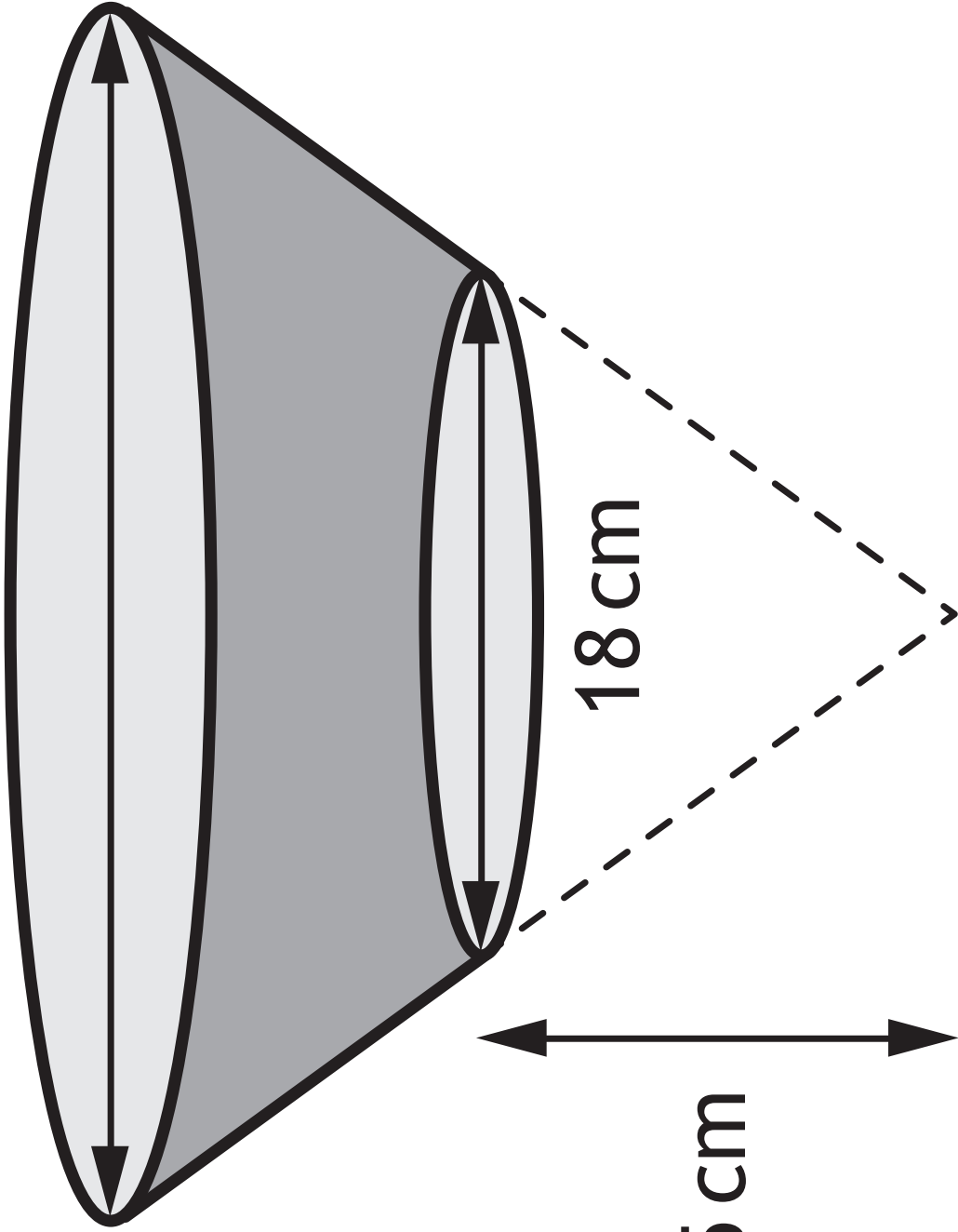

24 cm

18 cm

13.5 cm

Section 3 Artwork Examples (continued)

48pt Artwork

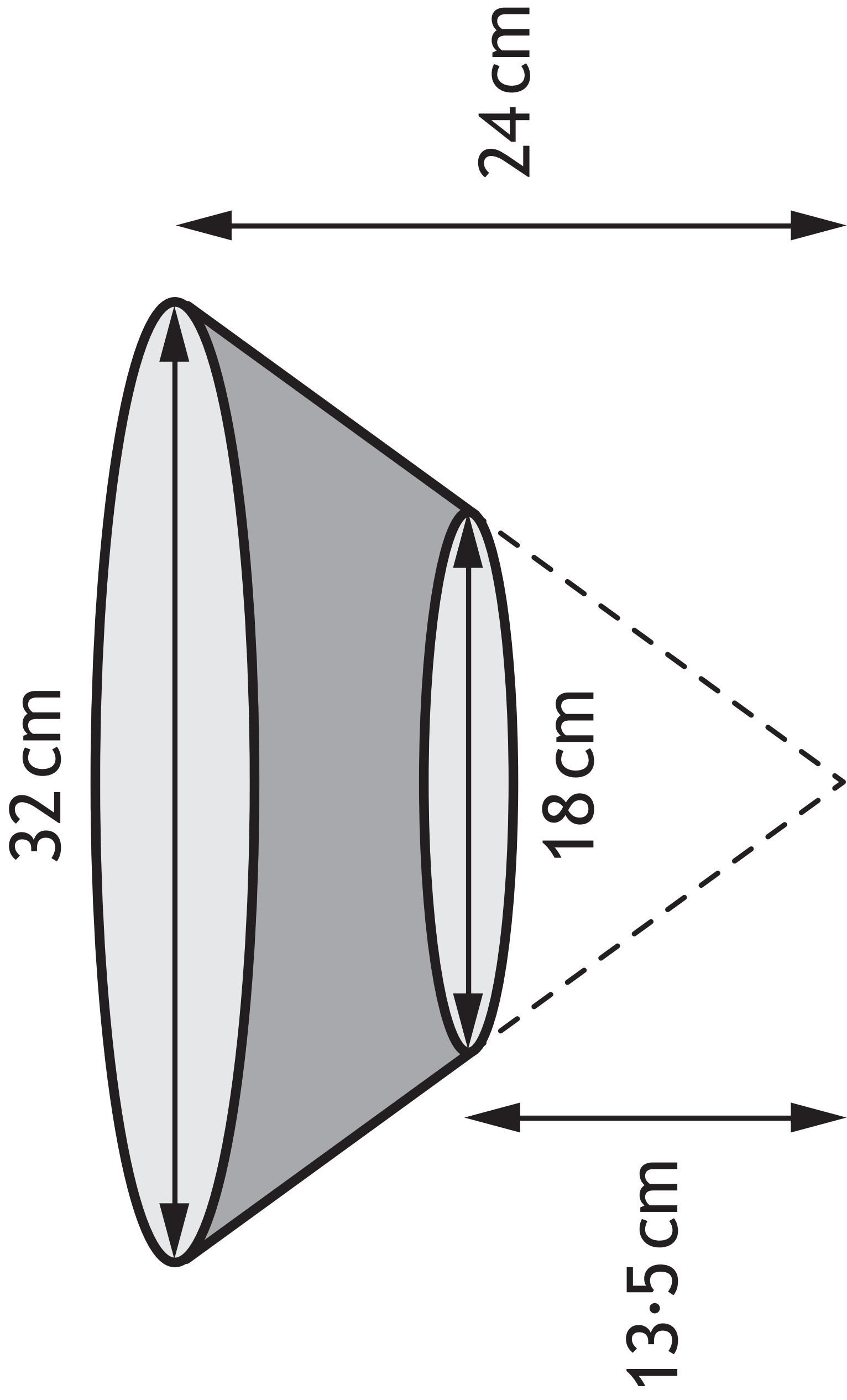

# Section 3 Artwork Examples (continued)

Simplified Artwork

Original Artwork

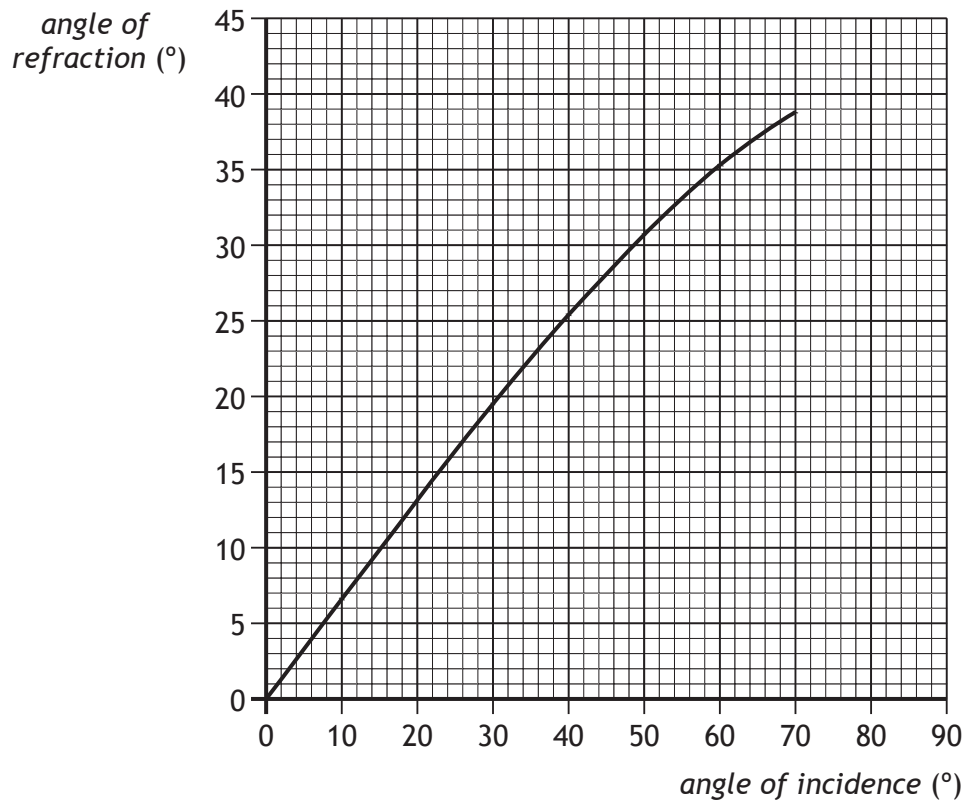

Simplified Artwork

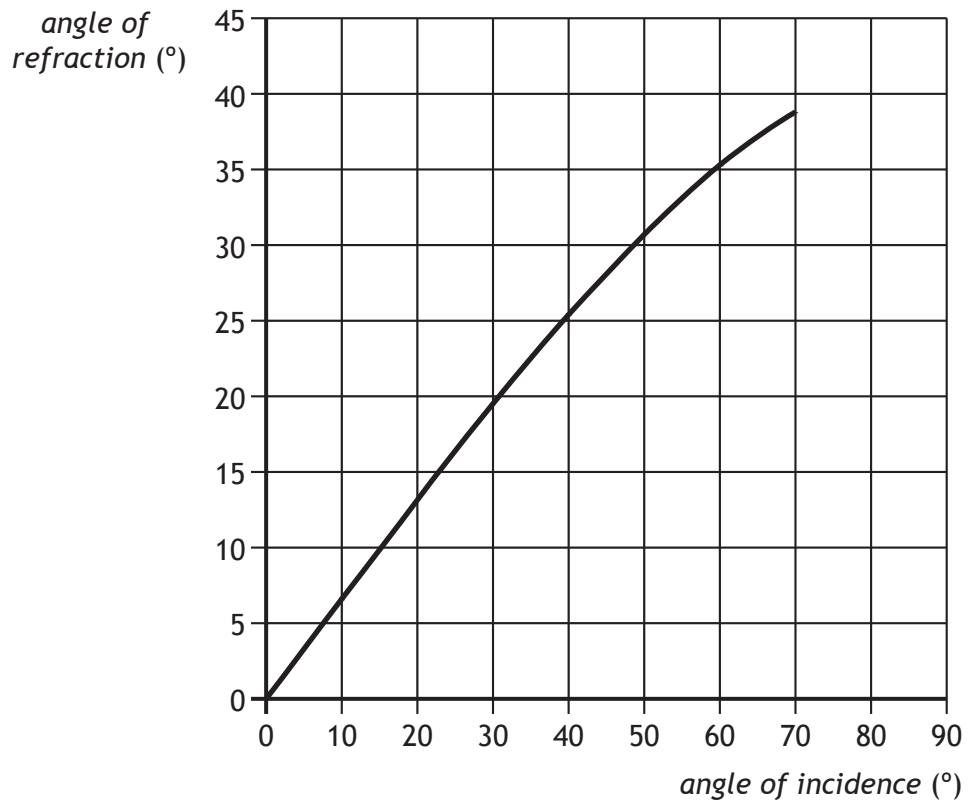

# Section 3 Artwork Examples (continued)

## Colour-Indicating Arrows Samples (Art and Design)



## Graphic Communication

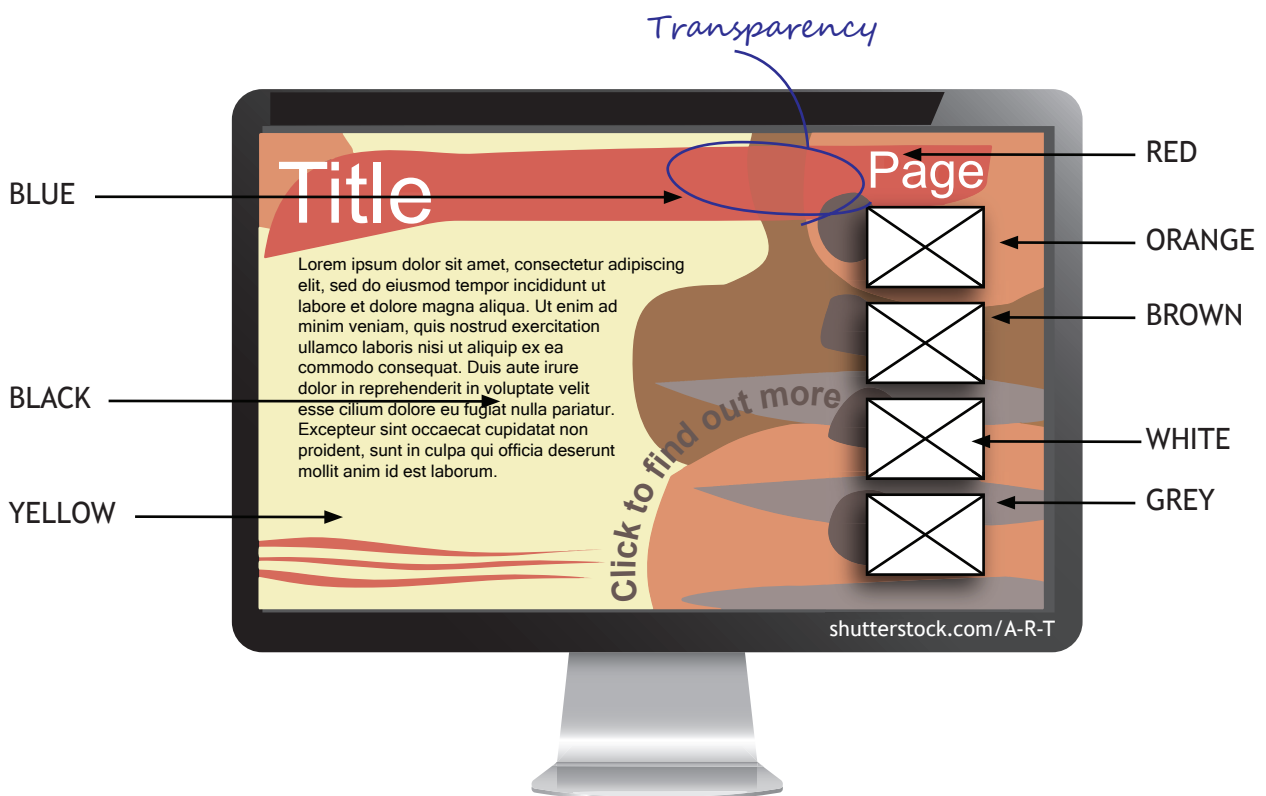

# Section 3 Artwork Examples (continued)

## Design and Manufacture

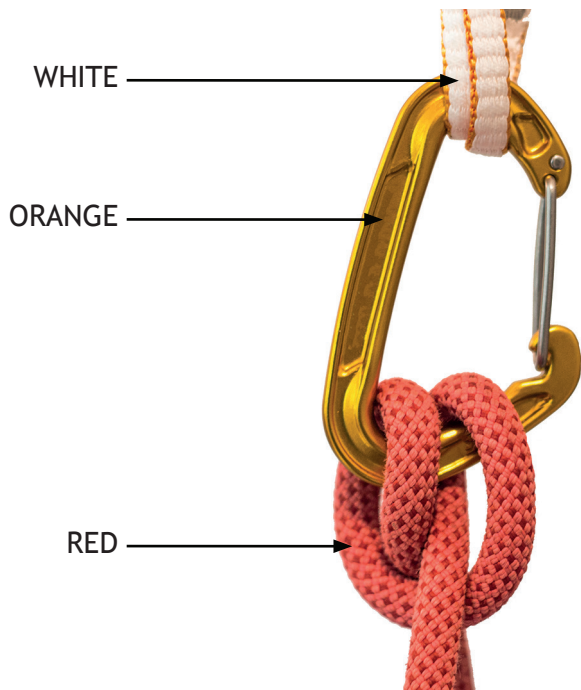

## Braille (original)

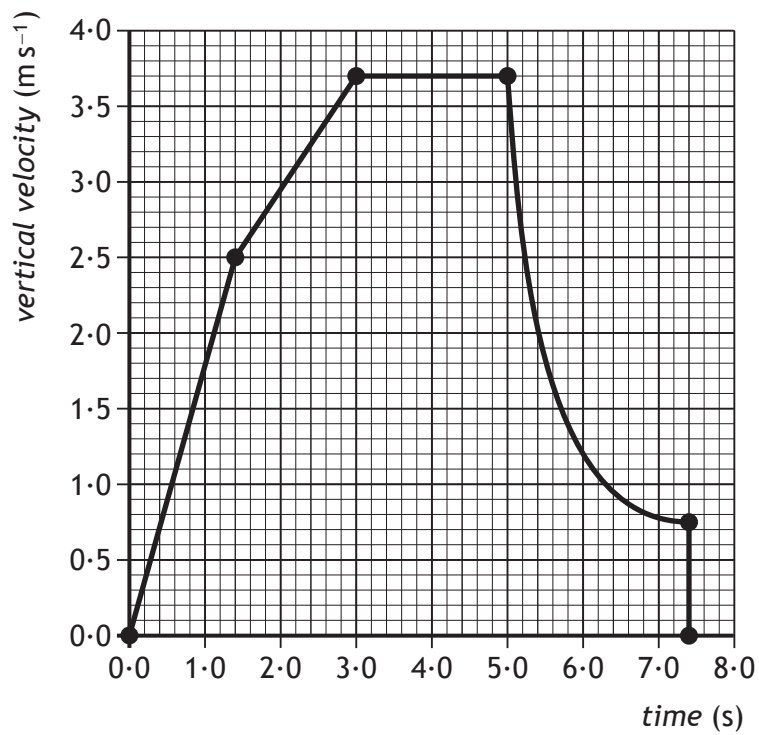

### Section 3 Artwork Examples (continued)

Braille Artwork (Braille Characters added by Braille Press)

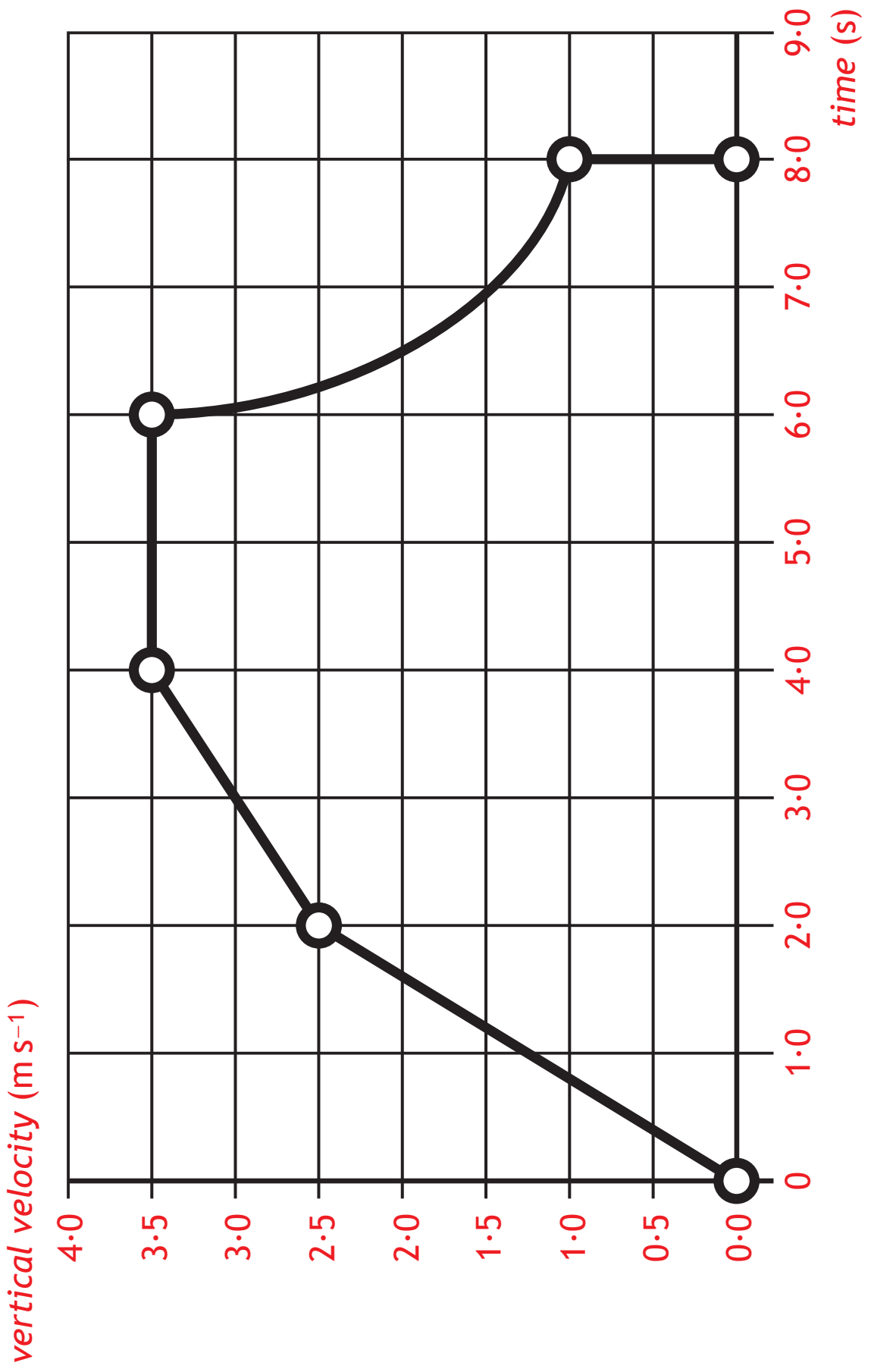

## Section 3 Artwork Examples (continued)

### Original Artwork

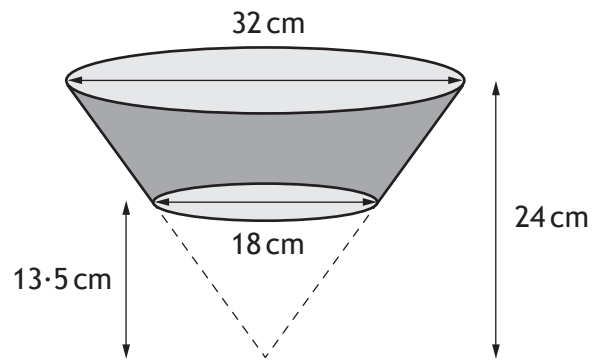

### No Greyscaling

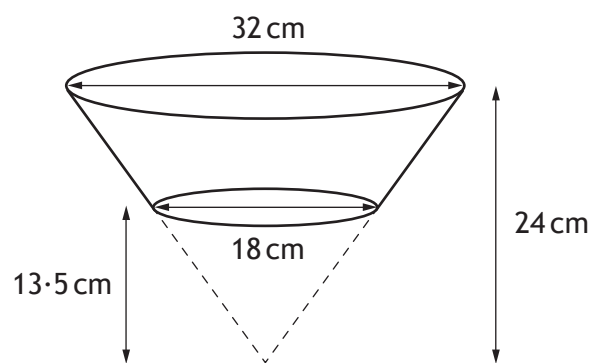



## Section 4

SQA Glossary - an example of terminology used within SQA in relation to adapted Question Papers, and where to request it.

**ARRANGEMENT INPUT BY COURSE**

Centre Code: 5010130 Centre Name: EA Secondary School Test1

Product Code X707 Biology

Product Level 76 Higher

Completion Date May 2017

120000330	22 Dec 1993	Amy Lawson	<input type="checkbox"/>	Arrangement Exists
120000096	13 Nov 1997	Stuart John Adamson	<input type="checkbox"/>	Arrangement Exists
120000290	04 Sept 1994	Caroline Armour	<input checked="" type="checkbox"/>	
120000394	12 Jan 1997	Keith Andrew James Barber	<input type="checkbox"/>	Arrangement Exists
120000495	28 Dec 1997	Jack L Bell	<input type="checkbox"/>	

Adapted Paper

Adapted Print

Font Size  Font Type  Paper Size  Paper Orientation

Braille

Coloured Paper  Please Select

Modified Contents  Details  72 Chars left

Optionality  Please Select

Digital Question Paper

This is a screenshot of the Adapted Paper tab on the Assessment Arrangements Request (AAR) system. The screen is already pre-populated with the “Standard Enlarged” Question Paper Details.

N18 Standard SQA Font, A3, Portrait.

Any changes to the “Standard Enlarged” request are made using the alternative drop down menus.

The alternative drop down menus provide the options for fonts and sizes available.

Fonts available: Standard SQA (Trebuchet), Arial, Comic Sans, OpenDyslexic and Other. Standard SQA font will include any other fonts used in the mainstream paper.

Sizes available: N14, N18, N24, N36, N48 and Other.

When selecting “Other” please give full details in the Additional Comments free text box within the ‘Additional’ tab’. Please explain why none of the SQA standard options are suitable.

## Section 4 (continued)

You must ensure that the adaptations requested are familiar to the candidate and that these match the adapted materials you produce in teaching and learning. The font size and paper size requested can have an impact on the size of the question paper which may disadvantage the candidate - see examples below.

### Example of how the page extents increase with enlarged font size.

Human Biology Higher Question Paper = 36 pages.

Human Biology Higher Adapted Question Paper 48 Arial A4 Landscape = 191 pages.

Computing Higher Question Paper = 28 pages

Computing Higher Adapted Question Paper 36 Comic Sans A4 Portrait = 149 pages.

National 5 Spanish Reading Question Paper = 12 pages.

National 5 Spanish Reading Question Paper 24 Standard A4 = 23 pages.

### Most requested page extent comparison table

	Standard 11pt A4	14pt on A4	18pt on A4	24pt on A4	24pt on A3
English N5 Critical Reading	28	32	41	57	43
Biology N5 Paper 2	28	34	37	51	38
Geography N5	24	29	39	42	37
Biology H Paper 2	33	35	46	61	46

Please reference "Assessment Arrangements Request system (AAR) 2023-24 A guide for centres" which can be found on the Assessment Arrangements page of the SQA Secure site under NQ, then Assessment Arrangements.