

FOR OFFICIAL USE

--	--	--	--	--	--

C

0600/403

Total
Mark

--

NATIONAL
QUALIFICATIONS
2009

MONDAY, 18 MAY
1.00 PM – 2.00 PM

CRAFT AND DESIGN
STANDARD GRADE
Credit Level

Fill in these boxes and read what is printed below.

Full name of centre

--

Town

--

Forename(s)

--

Surname

--

Date of birth

Day Month Year

--	--	--	--	--	--	--	--

Scottish candidate number

--	--	--	--	--	--	--	--	--	--

Number of seat

--

- 1 Answer all the questions.
- 2 Read every question carefully before you answer.
- 3 Write your answers in the spaces provided.
- 4 Do **not** write in the margins.
- 5 All dimensions are given in millimetres.
- 6 Before leaving the examination room you must give this book to the invigilator. If you do not, you may lose all the marks for this paper.



ATTEMPT ALL QUESTIONS

DO NOT
WRITE IN
THIS
MARGIN

1. A magazine rack manufactured from acrylic is shown below.

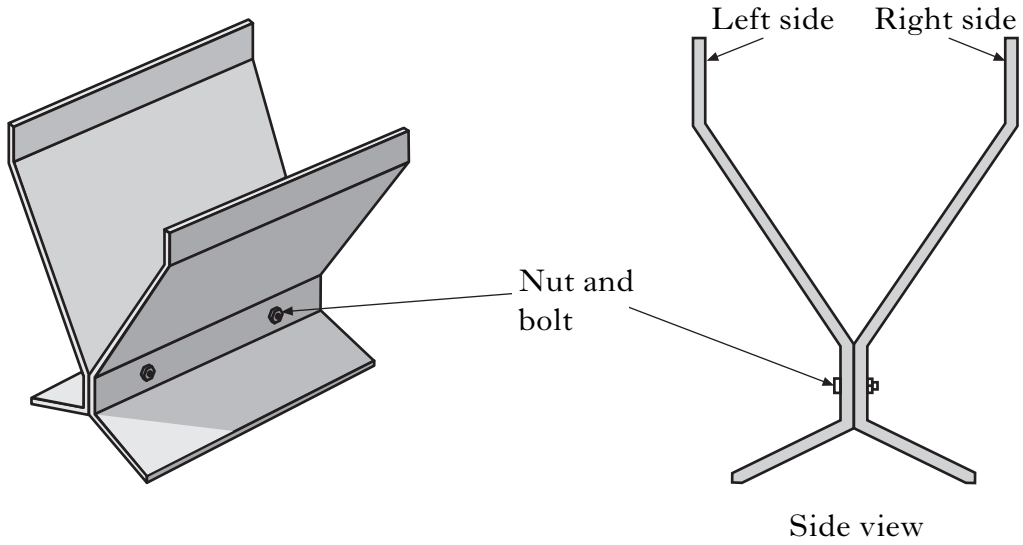

(a) Acrylic is a thermoplastic.

State what is meant by the term thermoplastic.

1
0

(b) State **two** reasons why acrylic was considered a suitable material for the manufacture of the magazine rack.

(i) _____

(ii) _____

1
0
1
0

(c) State **one** disadvantage of using acrylic.

1
0

1. (continued)

Shown below are the acrylic sheets prior to bending.

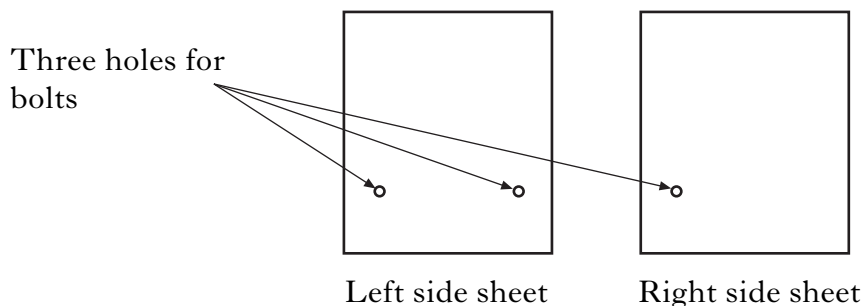

(d) State why only three holes were drilled at this stage.

1
0

(e) A number of the magazine racks are to be made.

State how the magazine racks could be bent to an identical shape.

1
0

[Turn over

2. A stainless steel park bench is shown below.

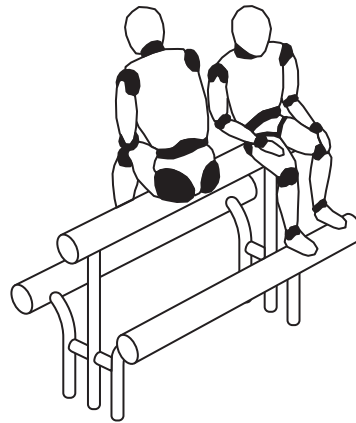
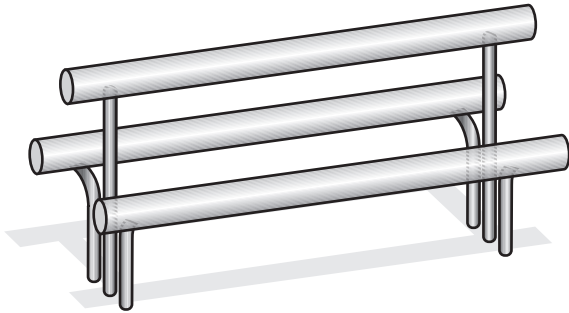

- (a) The primary function of the bench is seating.
State a secondary function of this park bench.

1
0

- (b) The designer used a table of human dimensions when designing the park bench.

- (i) State the name of this type of data.

1
0

- (ii) State the stage in the design process when this data would be gathered.

1
0

- (iii) The bench was designed to suit a range of people between the 5th and 95th percentiles.

State a reason why people below the 5th percentile would find the bench difficult to use.

1
0

- (c) Stainless steel, a ferrous metal, was used in the manufacture of the bench.

- (i) State what is meant by the term ferrous metal.

1
0

- (ii) State **two** reasons why stainless steel is a suitable material for the park bench.

1 _____

1
0

2 _____

1
0

2. (continued)

(d) The bolt shown below is used to assemble the bench.

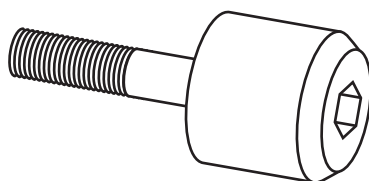

Some of the processes used to manufacture the bolt on a metal work lathe are shown below.

Process (A)

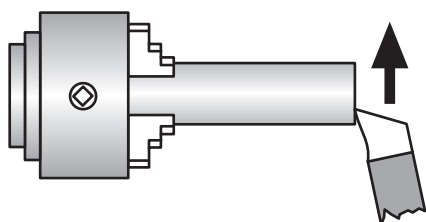

Process (B)

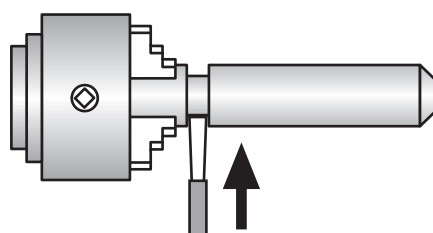
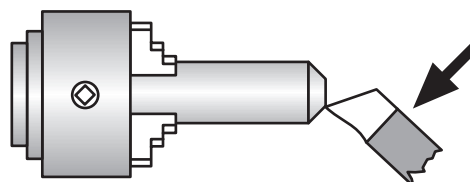

Process (C)

(i) State the name of process (A).

1
0

(ii) State a reason for the 45 degree chamfer at process (B).

1
0

(iii) State the name of the slide that would need to be adjusted when turning the chamfer at process (B).

1
0

(iv) State the name of process (C).

1
0

2. (continued)

(e) State **two** procedures or adjustments that ensure a high quality finish is achieved when turning metal.

1 _____

2 _____

1
0
1
0

(f) The tool shown below was used during the manufacture of the bolt.

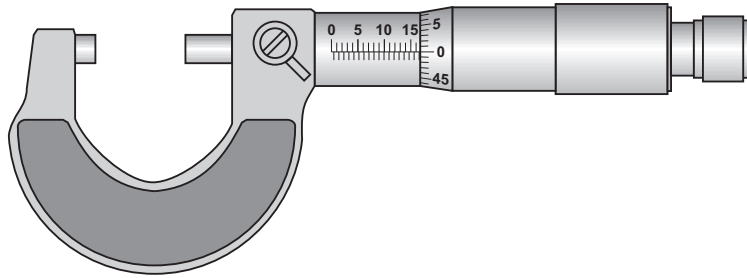

(i) State the name of this tool.

1
0

(ii) State a reason why this tool was used rather than a pair of outside callipers.

1
0

(g) The tool shown below was used to cut the thread on the bolt.

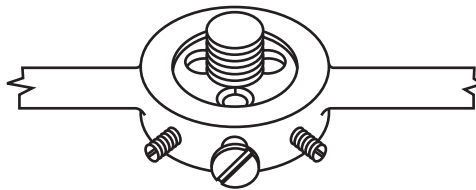

State **two** procedures that ensure a high quality thread is cut on the bolt.

1 _____

2 _____

1
0
1
0

3. Hexagonal wall shelves are shown below.

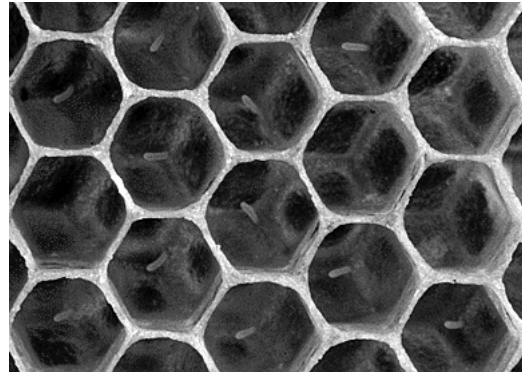
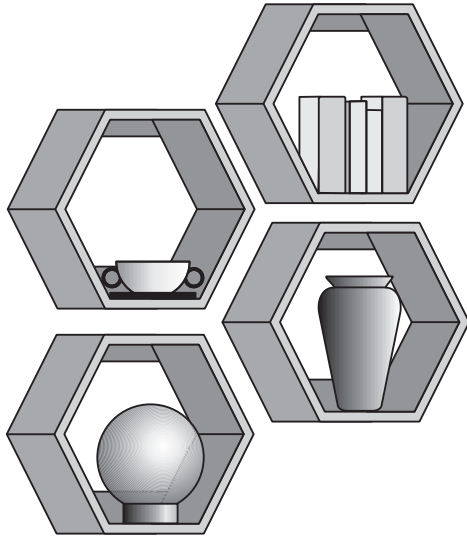

Honeycomb

A thematic approach helped inspire the design for the shelves.

(a) State one other technique that can be used to generate ideas.

1
0

(b) Aesthetics were considered when designing the shelves.

State what is meant by the term aesthetics.

1
0

(c) Proportion is considered an important aesthetic factor.

State **three** other aesthetic factors.

(i) _____

1
0

(ii) _____

1
0

(iii) _____

1
0

(d) The shelves are made of plywood.

Describe the constructional feature that gives plywood its strength.

Sketches may be used to illustrate your answer.

1
0

4. A school enterprise group designed and made the vase shown below.

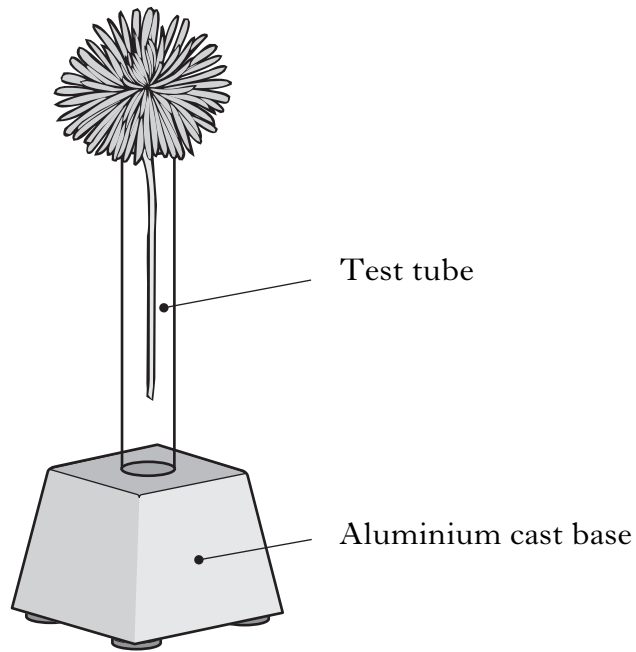

(a) Market research was carried out during the investigation stage of the design process.

(i) Explain the purpose of market research.

1
0

(ii) Describe how market research could be carried out.

1
0

(b) During the design process models were produced.

State **two** reasons why modelling is used in the design process.

(i) _____

1
0

(ii) _____

1
0

4. (continued)

(c) Sand casting was used during the manufacture of the base.

In order to cast the aluminium base, a wooden pattern was produced.

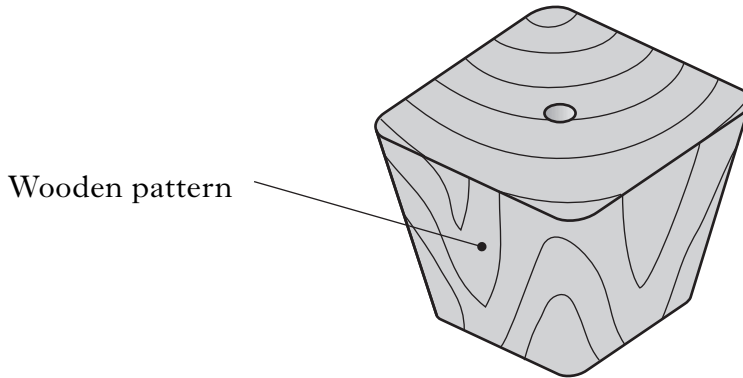

State **two** features of the pattern that would allow it to be easily removed from the moulding sand.

(i) _____

(ii) _____

(d) Other than aesthetic reasons, state why the school enterprise group used aluminium for casting.

(e) The cast body is shown below.

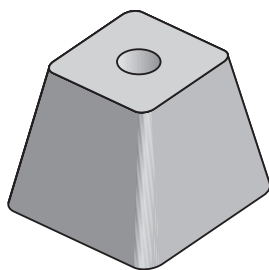

View of cast body

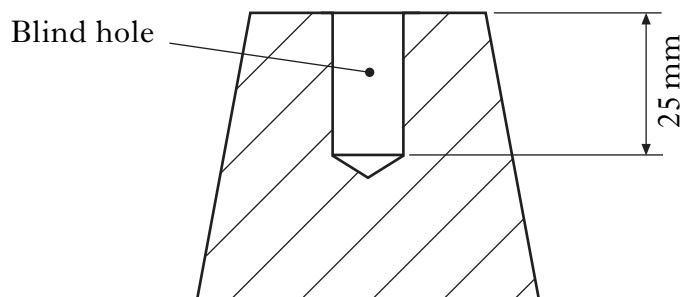

Sectional view of cast body

A blind hole was drilled using a pedestal drill.

State a method of ensuring the depth is 25 mm.

1
0
1
0

1
0

1
0

5. A candle holder is shown below.

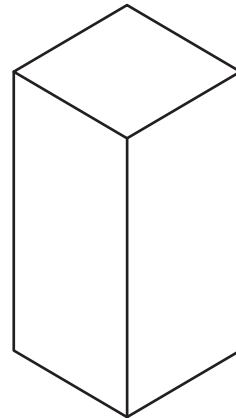
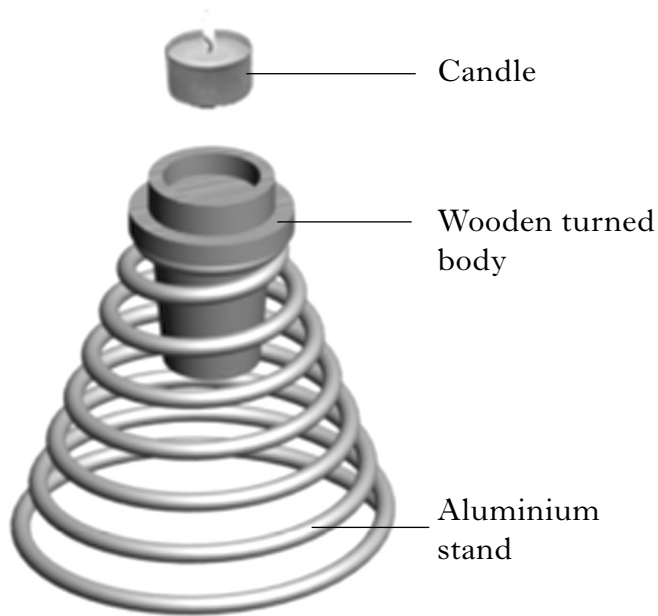

Wooden blank for body

(a) The wooden body was manufactured from a blank on a wood lathe.
Describe three stages in preparing a wooden blank before fitting to the lathe.
Sketches may be used to illustrate your answer.

Stage 1

Stage 2

1
0

1
0

5. (a) (continued)

Stage 3

1
0

(b) The wooden body is shown below.

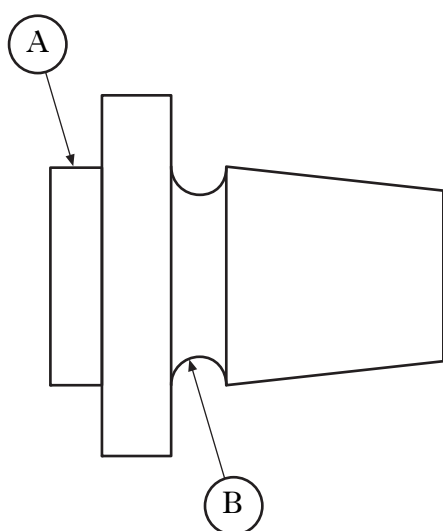

(i) State the name of the turning tool used to produce the square shoulder shown at (A).

1
0

(ii) State the name of the turning tool used to produce the groove shown at (B).

1
0

(iii) When wood turning, state an advantage of using a revolving (live) centre rather than a dead centre.

1
0

[Turn over

5. (continued)

(c) The tool below was used in the manufacture of the candle holder.

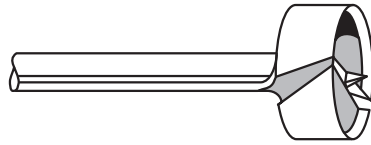

State the name of this tool.

1
0

(d) During the manufacture of the stand it was necessary to anneal the aluminium.

(i) State the purpose of annealing aluminium.

1
0

(ii) Describe the process of annealing aluminium.

2
1
0

6. A folding deck chair is shown below.

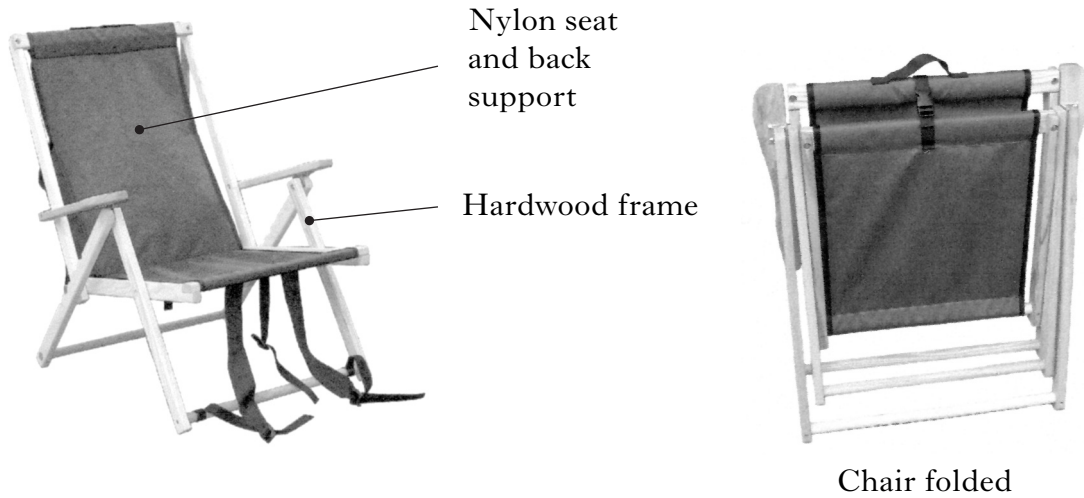

(a) State **two** advantages that a folding chair has over a non-folding chair.

Advantage 1

Advantage 2

(b) Ergonomics was considered when designing the chair.

(i) State what is meant by ergonomics.

(ii) State an ergonomic reason for using nylon material for the seat and back support.

(c) The frame of the chair is made of hardwood.

State the name of a suitable hardwood.

1
0

1
0

1
0

1
0

1
0

[Turn over

7. A decorative wooden box and stand are shown below.

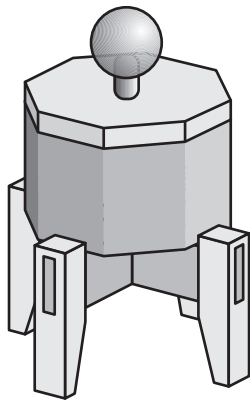

Assembled box

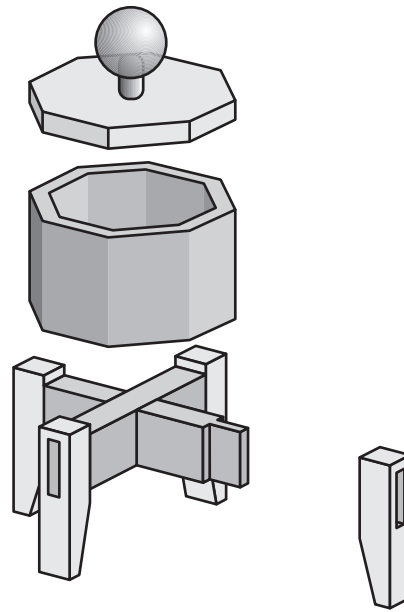

Exploded view showing joint (A)

(a) State the name of joint (A).

1
0

The tool shown below was used to mark out the joint.

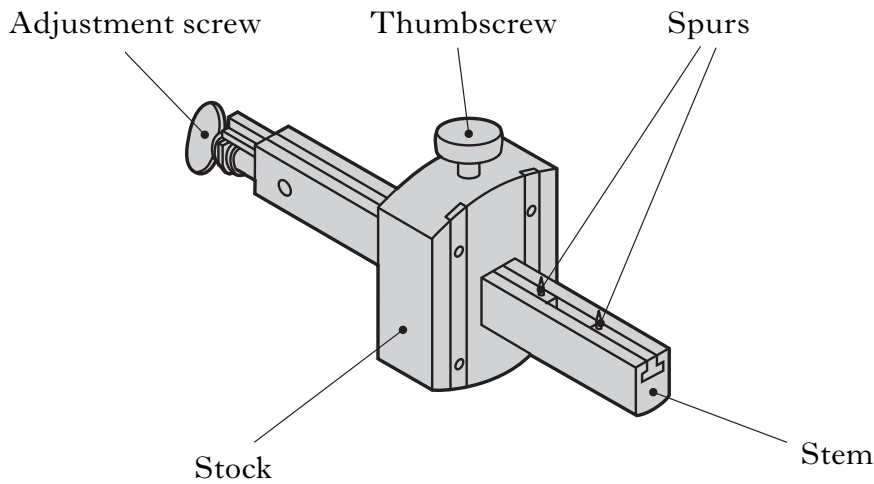

(b) (i) State the name of this tool.

1
0

(ii) State two adjustments that can be made to this tool.

Adjustment 1 _____

1
0

Adjustment 2 _____

1
0

7. (continued)

- (c) State the name of another joint that could have been used as an alternative to joint (A).

1
0

- (d) Joint (A) was “dry clamped”.
State the purpose of dry clamping.

1
0

- (e) The tool below was used in the manufacture of the box.

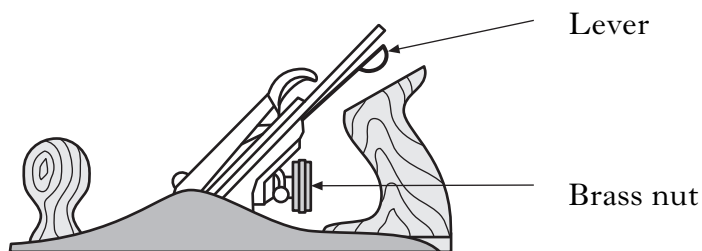

- (i) State the purpose of the lever.

1
0

- (ii) State the purpose of the brass nut.

1
0

[END OF QUESTION PAPER]

[BLANK PAGE]