

FOR OFFICIAL USE

--	--	--	--	--	--

C

KU PS

Total Mark

--	--

**3700/403**

NATIONAL  
QUALIFICATIONS  
2009

THURSDAY, 28 MAY  
1.00 PM – 2.30 PM

SCIENCE  
STANDARD GRADE  
Credit Level

Fill in these boxes and read what is printed below.

Full name of centre

Town

Forename(s)

Surname

Date of birth

Day Month Year

--	--	--	--	--	--	--	--

Scottish candidate number

--	--	--	--	--	--	--	--	--	--

Number of seat

- 1 Answer as many questions as you can.
- 2 Read the whole of each question carefully before you answer it.
- 3 Write your answers in the spaces provided. Showing working may help in some questions.
- 4 Before leaving the examination room you must give this book to the invigilator. If you do not, you may lose all the marks for this paper.





3. Air sacs are found in the lungs.

The diagram shows a single air sac and the blood vessel surrounding it.

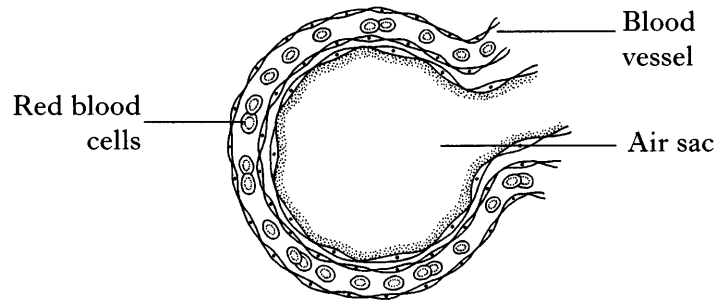

Marks

	KU	PS

(a) What type of blood vessel surrounds the air sac?

..... 1

(b) Name the substance in red blood cells which carries oxygen.

..... 1

(c) Cigarette smoke contains harmful substances.

Name the substance that

(i) reduces gas exchange in the air sacs.

..... 1

(ii) is addictive.

..... 1

**[Turn over**

4. James carried out an investigation to compare the hardness of different metal plates.

Marks

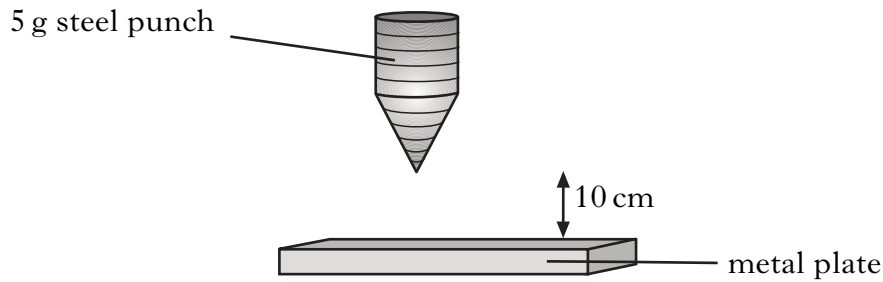

He dropped a 5 g steel punch on to a metal plate from a height of 10 cm.  
He measured the diameter of the dent.

Results

<i>Metal plate</i>	<i>Diameter of the dent (mm)</i>
brass	1
bronze	2

The investigation was **fair** but could be **improved** to make it more accurate and reliable.

Suggest **two improvements**.

- 1 .....
- .....
- 2 .....
- .....

2

KU	PS

5. (a) Different methods for detecting oil in rock formations are shown below.

test drilling	aerial survey
seismic survey	geological survey

Which method involves

(i) setting off small explosions and recording the echoes?

..... **1**

(ii) collecting and examining different rocks from an area?

..... **1**

(b) The fractions of crude oil can be separated by fractional distillation because they have different

- A viscosities
- B boiling points
- C flammabilities
- D colours.

Underline the correct answer. **1**

6. Complete the following sentences about toxic gases by circling the correct answer in each box.

Burning 

polyvinylchloride (PVC)
polystyrene
polyurethane

 produces hydrogen cyanide gas. **1**

Burning 

polyvinylchloride (PVC)
polystyrene
polyurethane

 produces hydrogen chloride gas. **1**

**[Turn over**

		KU	PS

Marks

KU	PS

7. The table shows the minimum and maximum water levels in a reservoir, as a percentage of full capacity, in three different years.

Year	Water level (%)	
	Minimum	Maximum
1995	46	92
2000	80	96
2005	55	88

Construct a single bar graph to show all of this information.  
(Additional graph paper, if required, may be found on page 24.)

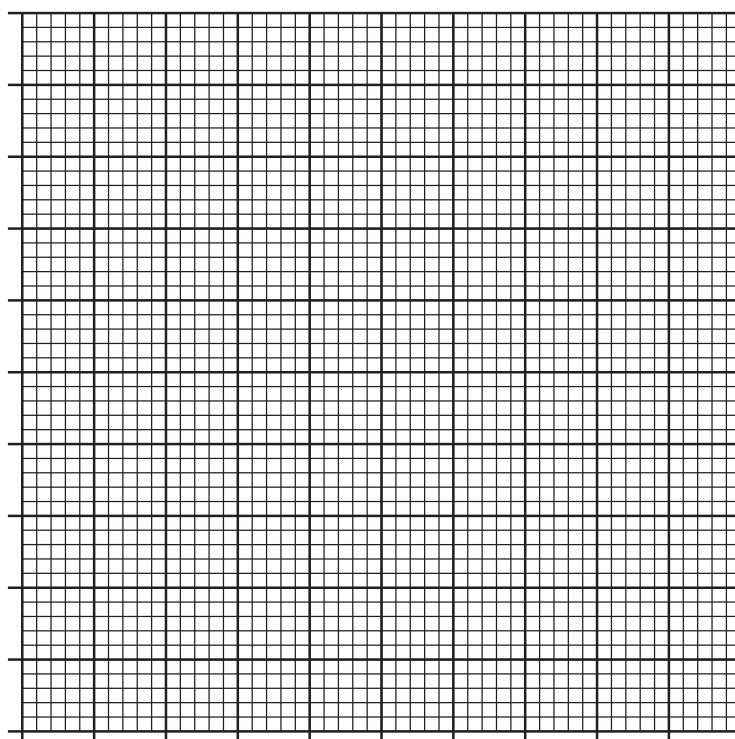

3







Marks

KU	PS

11. Organic waste from a farm was accidentally spilled into a river.

(a) Which graph below shows how the **number of bacteria** in the river would be affected?

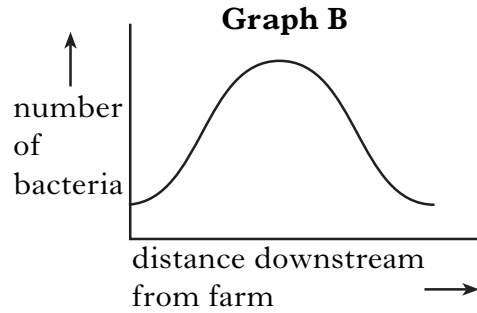
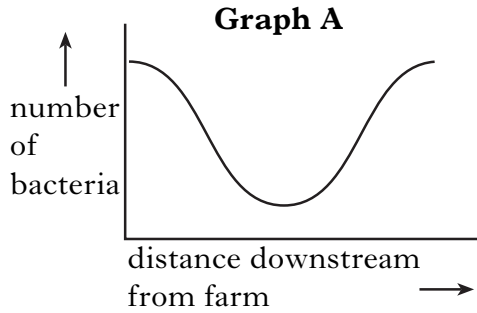

Answer **Graph** .....

1

(b) Which graph below shows how the **oxygen concentration** in the river would be affected?

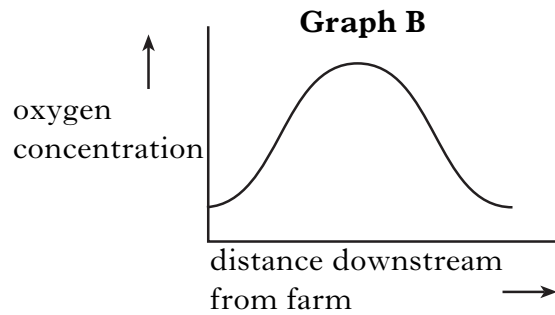
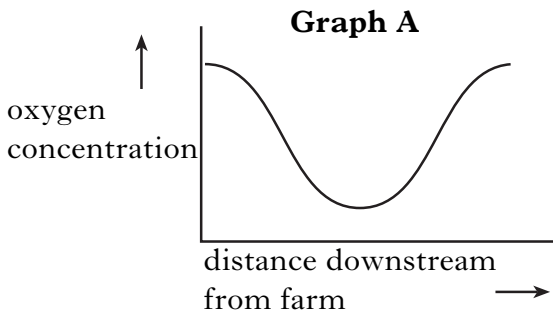

Answer **Graph** .....

1

(c) Which graph below shows how the **number of invertebrates** in the river would be affected?

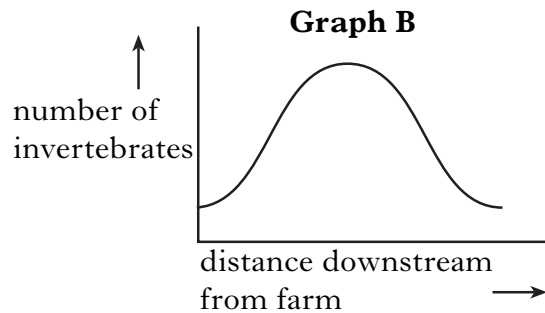
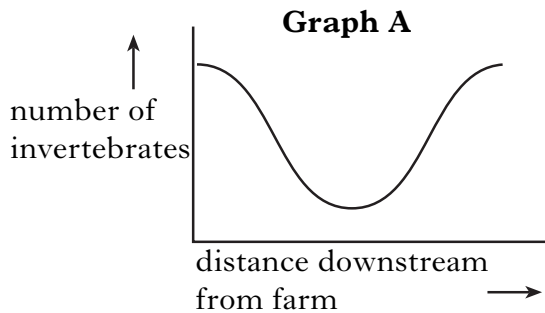

Answer **Graph** .....

1



Marks

KU	PS

13. (a) Complete the table below to show the **fuse rating** for each appliance.

<i>Appliance</i>	<i>Power rating (W)</i>	<i>Fuse rating (A)</i>
Table lamp	100	
Kettle	2000	

1

(b) The boxes below describe possible positions for the **switch** and the **fuse** in the electrical supply to a kettle.

1	switch in the live wire fuse in the neutral wire	2	switch in the earth wire fuse in the earth wire
3	switch in the live wire fuse in the live wire	4	switch in the earth wire fuse in the live wire

Which box describes the correct position for the switch **and** the fuse?

Box number .....

1

14. Select the correct word to complete each sentence below.

hypothermia	immunisation	hypertension
tuberculosis	circulation	anorexia

(a) ..... is a way of improving the body's defence against disease.

1

(b) ..... is an inability to maintain core body temperature.

1

(c) ..... is a disorder resulting from a refusal to eat sufficient food.

1





17. Some properties of materials are shown below.

resistance to corrosion	flexibility	electrical resistance
thermal conductivity	strength	electrical conductivity
wear resistance	hardness	heat resistance

Marks

KU	PS

(a) Which **two** properties would be **most** important for a new material being developed for making kitchen work surfaces?

1 .....

2 .....

2

(b) Which property fits each of the descriptions below?

(i) The ability of a material to allow heat to pass through it.

.....

1

(ii) The ability of a material to support heavy loads without breaking.

.....

1

[Turn over

Marks

KU	PS

18. There are four different types of blood groups. The blood group you have depends on the genes inherited from your parents.

Blood group	Genes inherited from parents
O	OO
A	AA or AO
B	BB or BO
AB	AB

The diagram below shows a family tree.

A circle stands for a female. A square stands for a male.

The top half of each circle or square shows the person's blood group.

The bottom half of each circle or square shows the genes inherited from the person's parents, one from each parent.

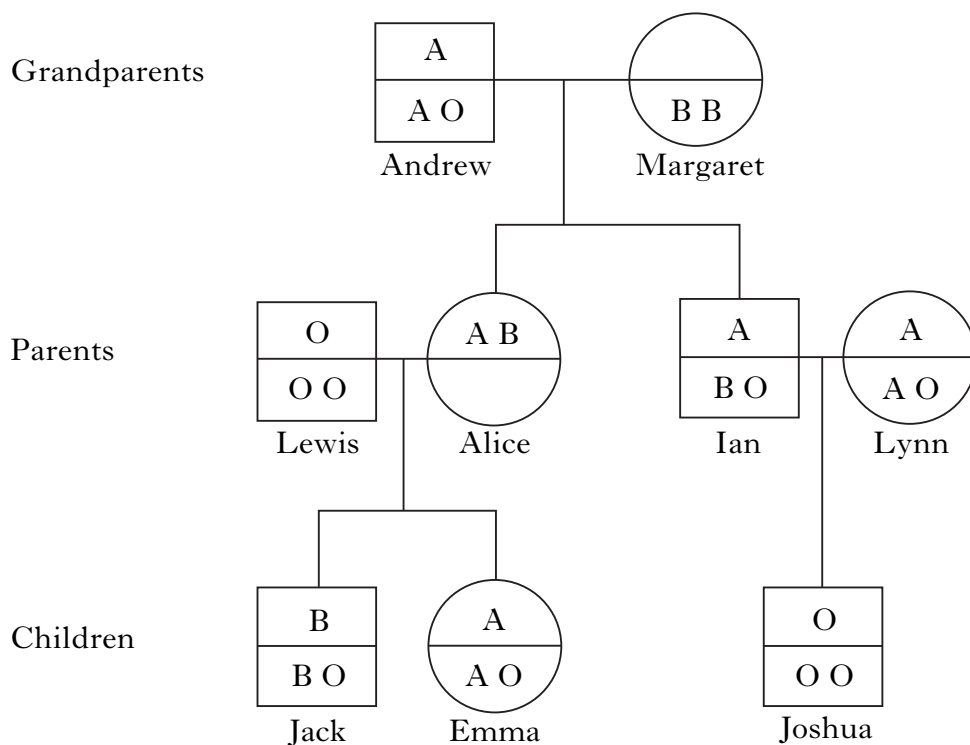

**18. (continued)**

Use all of the information to answer the following questions.

(a) What blood group does Andrew have?

.....

(b) How many males in the family tree have blood group O?

.....

(c) Complete the family tree to show

(i) Margaret's blood group

(ii) the genes passed on to Alice from her parents.

(d) Joshua marries a woman with AO genes.

Their children could have

- 1 only blood group O
- 2 either blood group O or blood group A
- 3 either blood group O or blood group B
- 4 only blood group A.

**Underline** the correct answer.

Marks

KU	PS
1	
1	
1	
1	

[Turn over

19. Some information about British coins is given below.



Marks

<i>Coin</i>	<i>Composition</i>	<i>Mass</i> (g)	<i>Thickness</i> (mm)	<i>Shape</i>
One pound	70% copper 5.5% nickel 24.5% zinc	9.50	3.15	circular
Fifty pence	75% copper 25% nickel	8.00	1.78	heptagonal
Twenty pence	84% copper 16% nickel	5.00	1.70	heptagonal
Ten pence	75% copper 25% nickel	6.50	1.85	circular
Five pence	75% copper 25% nickel	3.25	1.70	circular
Two pence (before September 1992)	97% copper 0.5% tin 2.5% zinc	7.12	1.85	circular
One pence (before September 1992)	97% copper 0.5% tin 2.5% zinc	3.56	1.65	circular

There are three groups of British coins. One and two pence coins belong to a group called “copper” coins. Before September 1992 these were made from an alloy called bronze. Since September 1992 one and two pence coins have been made from copper-plated steel. “Silver” coins are made from an alloy, called cupro-nickel. Silver coins include the five, ten, twenty and fifty pence coins. The one pound coin is in another group called “yellow metal” coins. The one pound coin is made from an alloy called nickel-brass.

KU	PS



20. The effect of different concentrations of nitrate fertiliser on the yield of two different crops is shown in the table below.

Marks

Concentration of fertiliser (kg/Ha)	Yield of crop (kg/Ha)	
	Crop A	Crop B
0	150	100
40	290	200
80	400	270
120	460	300
160	470	310

(a) Using the same axes, show these results as **two line graphs**.  
(Additional graph paper, if required, is provided on page 24.)

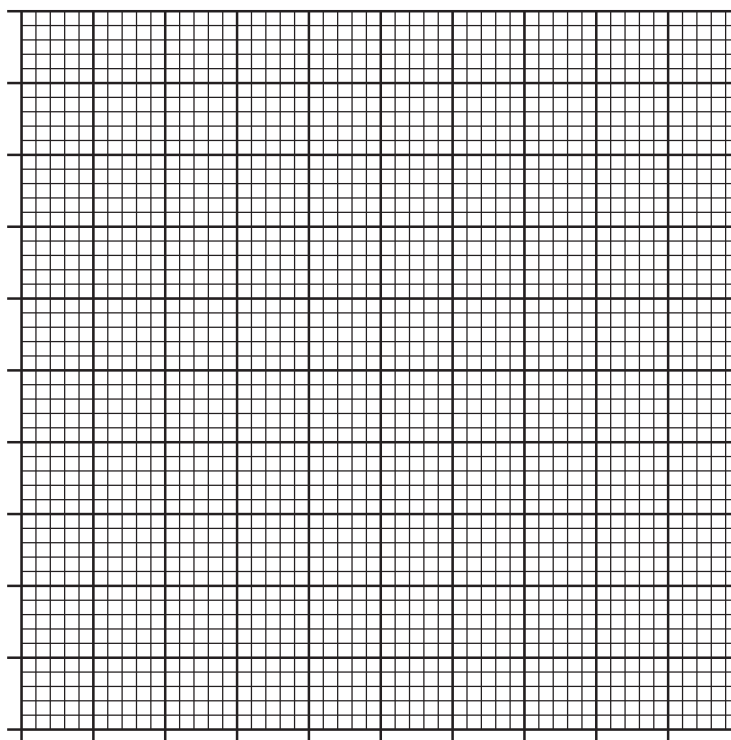

(b) Draw **two** conclusions from this information.

- 1 .....
- .....
- 2 .....
- .....

(c) Predict the yield of crop A when the concentration of fertiliser is 180 kg/Ha.

..... kg/Ha

	KU	PS
3		
2		
1		

Marks

KU	PS

21. The diagram shows the four chambers inside the heart.

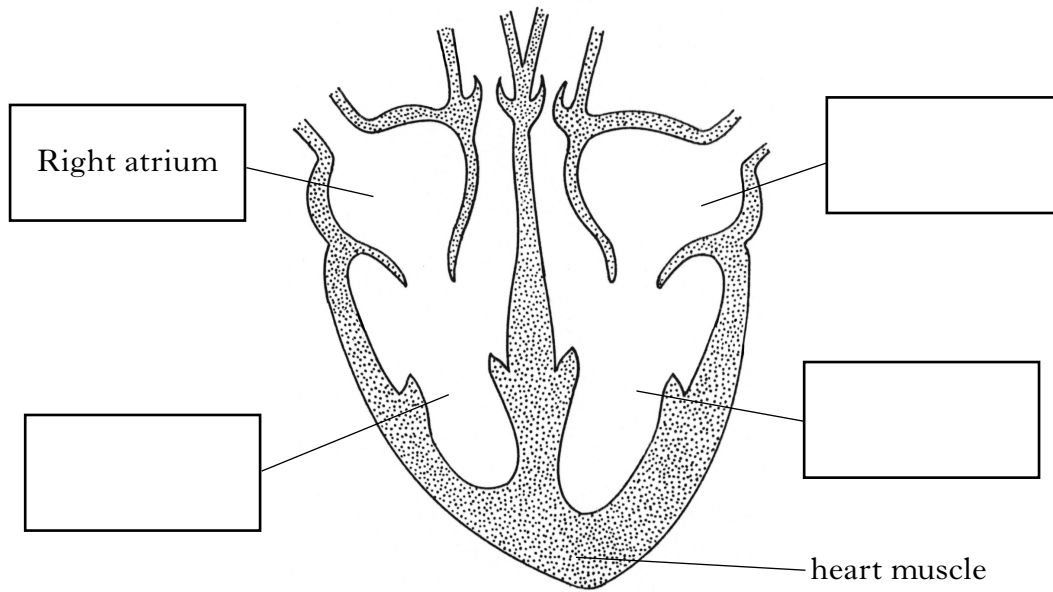

(a) Label the diagram to show the names of the other three chambers. 2

(b) A heart attack can be caused by a lack of food and oxygen in blood getting to the heart muscle.

Name the blood vessel which carries blood to the heart muscle.

..... 1

(c) The heart contains valves.

What is the function of a valve?

..... 1

**[Turn over**

Marks

KU	PS

22. Computer controlled tests can be carried out to investigate what happens when a lorry crashes into a stationary car. No human drivers are involved in these tests.



When a lorry crashes into a stationary car they stick together and move off together. The speed at which they move off together can be found using this equation.

$$S_{L+C} = \frac{m_L \times S_L}{m_{L+C}}$$

where

$S_{L+C}$  = the speed at which the **lorry** and **car** move off together

$m_L$  = the mass of the **lorry**

$S_L$  = the speed of the **lorry** before the crash

$m_{L+C}$  = the **total** mass of the **lorry** and the **car** when they stick together

(a) A lorry has a mass of 5 000 kg and a speed of 12 m/s.  
It crashes into a stationary car which has a mass of 1 000 kg.

(i) Calculate the value of  $m_{L+C}$ .

Space for working

Answer ..... kg     **1**

(ii) Calculate the speed at which the lorry and car move off together.

Space for working

Answer ..... m/s     **1**



ADDITIONAL GRAPH PAPER FOR USE IN QUESTION 7

Marks

KU	PS

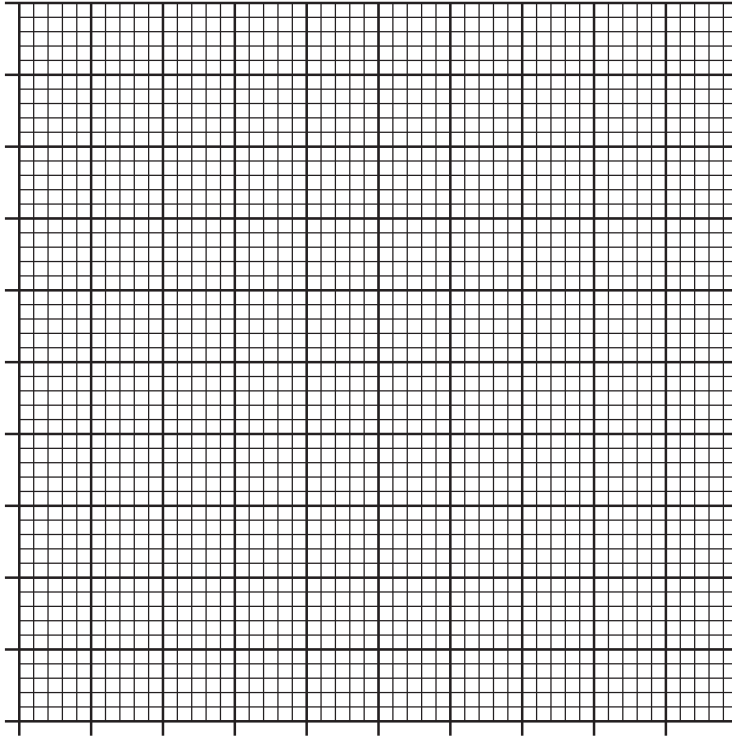

ADDITIONAL GRAPH PAPER FOR USE IN QUESTION 20(a)

