

FOR OFFICIAL USE

--	--	--	--	--	--

G

Total

0600/402

NATIONAL
QUALIFICATIONS
2009

MONDAY, 18 MAY
10.20 AM–11.20 AM

CRAFT AND DESIGN
STANDARD GRADE
General Level

Fill in these boxes and read what is printed below.

Full name of centre

Town

Forename(s)

Surname

Date of birth

Day Month Year

--	--	--	--	--	--	--	--

Scottish candidate number

--	--	--	--	--	--	--	--	--	--

Number of seat

- 1 Answer all the questions.
- 2 Read every question carefully before you answer.
- 3 Write your answers in the spaces provided.
- 4 Do **not** write in the margins.
- 5 All dimensions are given in millimetres.
- 6 Before leaving the examination room you must give this book to the invigilator. If you do not, you may lose all the marks for this paper.



ATTEMPT ALL QUESTIONS

1. The wooden clothes hanger shown below is designed to hang in a wardrobe or be freestanding.

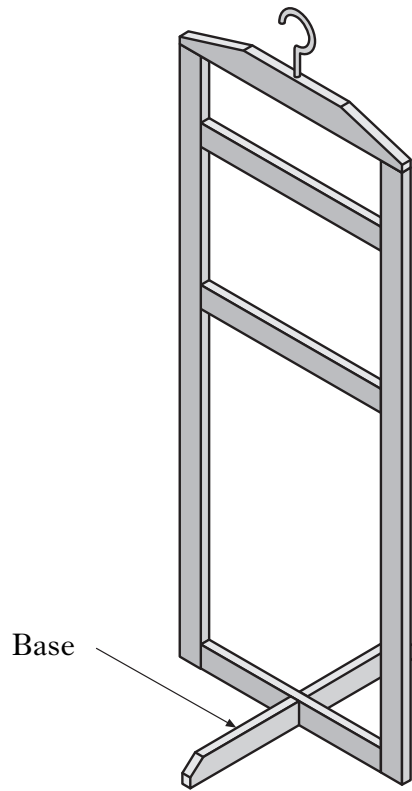

- (a) The wood joints shown below were considered during the design of the hanger.
State the name of each joint.

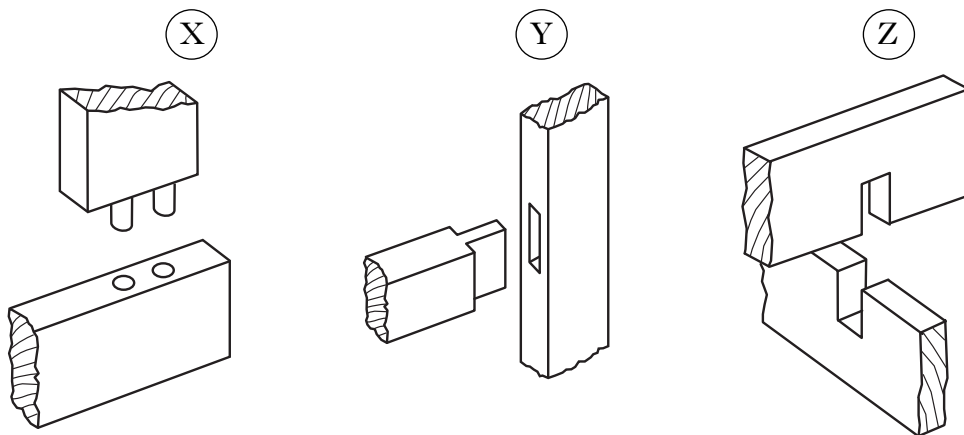

Joint (X) _____

Joint (Y) _____

Joint (Z) _____

1
0
1
0
1
0

1. (continued)

(b) One half of joint (Z) is shown below.

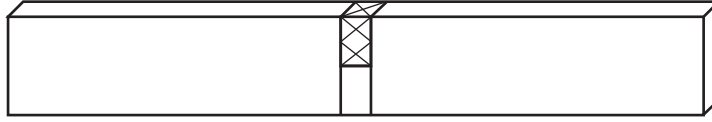

(i) The tools used to mark out the joint are shown below. State the names of these tools.

Tool (A)

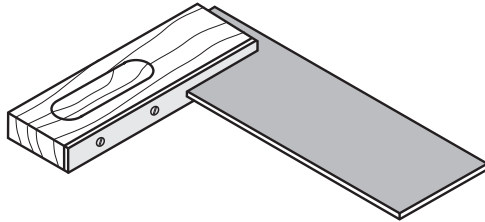

Tool (A) _____

Tool (B)

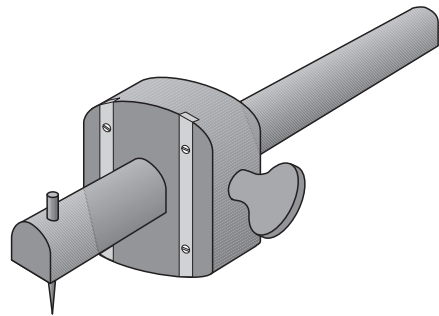

Tool (B) _____

1
0
1
0

(ii) The tools used in the manufacture of the joint are shown below. State the names of these tools.

Tool (C)

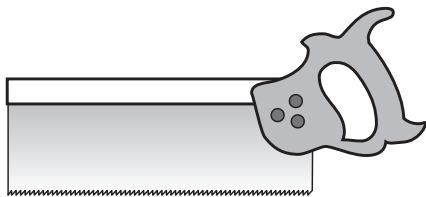

Tool (C) _____

Tool (D)

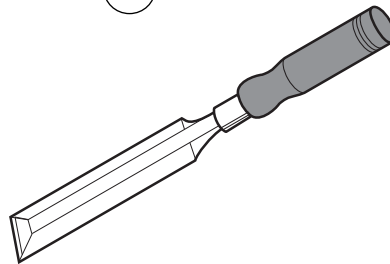

Tool (D) _____

1
0
1
0

(c) Varnish was applied to the hanger. State **two** reasons for applying a varnish finish.

Reason 1 _____

Reason 2 _____

1
0
1
0

2. A mild steel, wall mounted coat rack is shown.

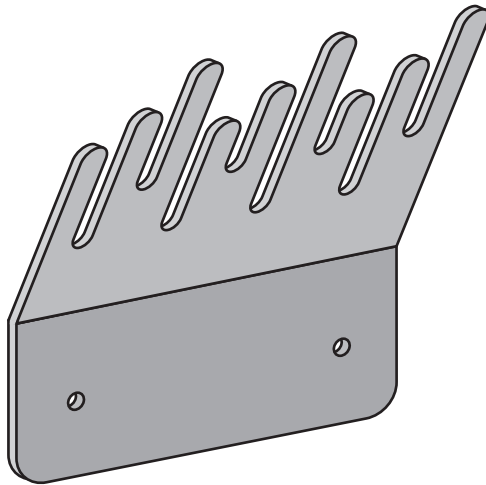

(a) The coat rack was marked out using the following tools. State the name and use of each tool.

(i) Name _____

Use _____



1
0

(ii) Name _____

Use _____

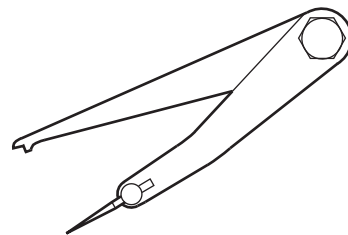

1
0
1
0

(iii) Name _____

Use _____

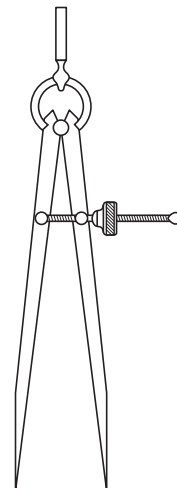

1
0
1
0

1
0

2. (continued)

(b) The following machine was used in the manufacture of the coat rack.

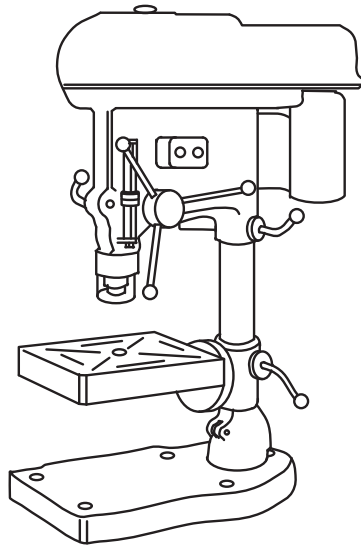

(i) State the name of this machine. _____

1
0

(ii) State **two** safety checks that should be carried out before starting the machine.

Check 1 _____

1
0

Check 2 _____

1
0

(c) The following tool was used when forming the coat rack.

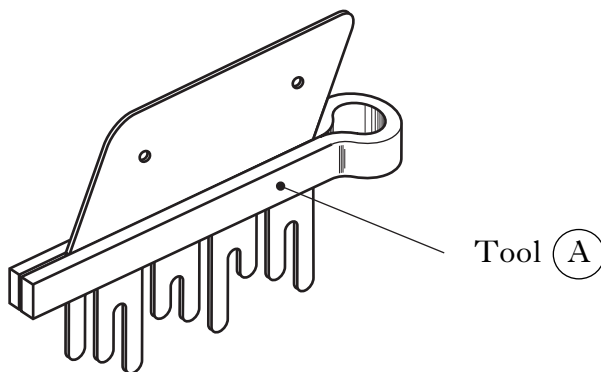

State the name of tool (A). _____

1
0

(d) State a suitable finish, apart from paint, that could be applied to the coat rack.

1
0

3. A design for a DVD storage unit is shown below.

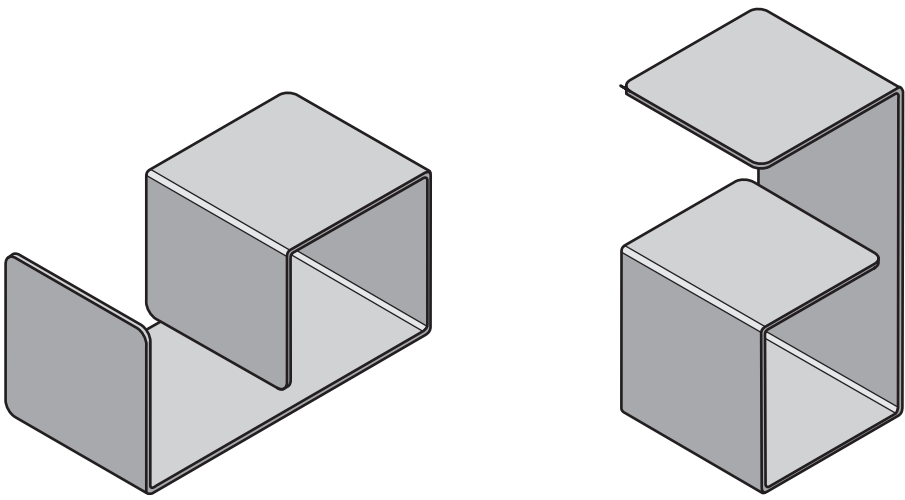

(a) (i) State **two** factors that would affect the overall size of the unit.

1 _____

2 _____

1
0
1
0

(ii) Metal and plastic were considered as possible materials for the unit. State the name of a suitable:

Non-ferrous metal; _____

Thermoplastic. _____

1
0
1
0

(b) An incomplete design specification for the unit is given below. Complete the design specification using each of the given design factors.

Design factor

Specification statement

Material

Must be made from a single piece of thermoplastic

Aesthetics

1
0

Ergonomics

1
0

Safety

1
0

3. (continued)

(c) (i) Complete the sequence of operations required to finish the edges of the thermoplastic storage unit.

- 1. Cross file the edge flat
- 2. _____
- 3. Use “wet and dry” paper
- 4. _____

1
0

1
0

(ii) State why it is easier to finish the edges before the thermoplastic is bent.

1
0

(d) The equipment shown below was used to heat the thermoplastic before bending.

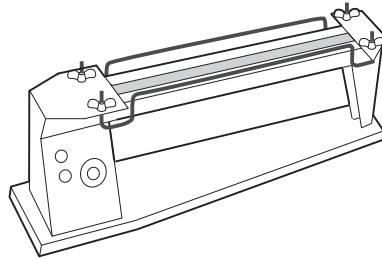

(i) State the name of this machine. _____

1
0

(ii) State a safety precaution that should be followed when handling hot plastic.

1
0

(iii) State what would happen if the plastic is not hot enough before it is bent.

1
0

(e) State the name of the stage in the design process when the finished DVD unit is tested.

1
0

4. A holder for remote controls is shown below.

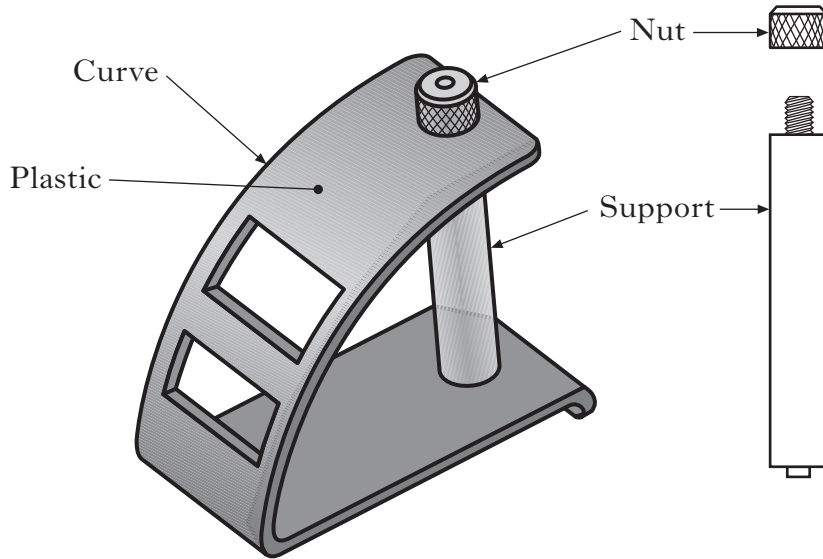

(a) The remote controls were measured as part of the design process.

State the stage in the design process when this would have been carried out.

1
0

(b) Aluminium and steel bars identical in length and diameter were available for the support. State **two** ways in which the aluminium bar could be identified from the steel bar.

1 _____

1
0

2 _____

1
0

(c) State a reason why the plastic supplied for the body had a polythene covering on it.

1
0

(d) State the name of the equipment used to heat the plastic before forming the curve.

1
0

4. (continued)

(e) The machine below was used to manufacture the support and nut.

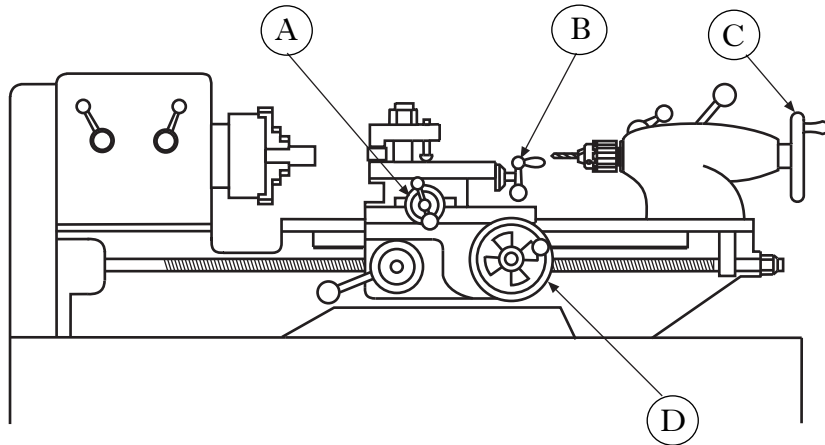

(i) Name this machine. _____

1
0

Handles (A), (B), (C) and (D) are shown on the machine above.

Select the correct handle to use when carrying out the following processes.

(ii) Parallel turning the support

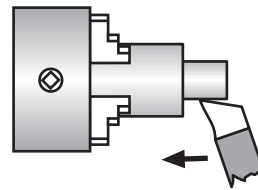

Handle _____

1
0

(iii) Drilling the nut

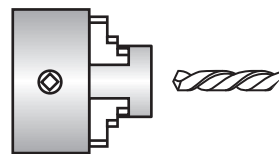

Handle _____

1
0

(f) The pattern on the nut was created using the tool shown below.

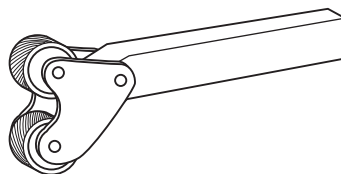

State the name of the process used to create the pattern on the nut.

1
0

5. A wooden kitchen roll holder is shown below.

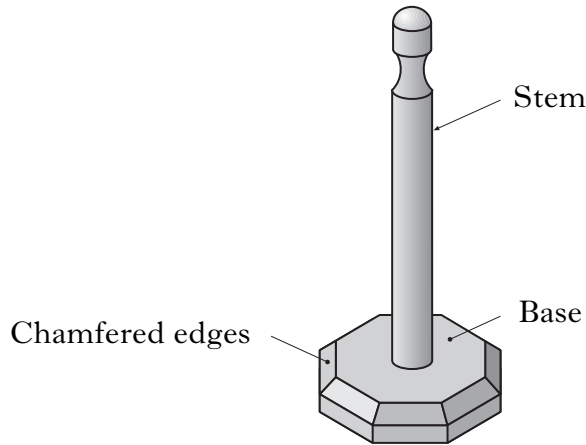

(a) The following statement appeared in the specification. "The holder must be stable."

State which feature of the holder gives it stability.

(b) The stem is turned on a wood lathe as shown below.

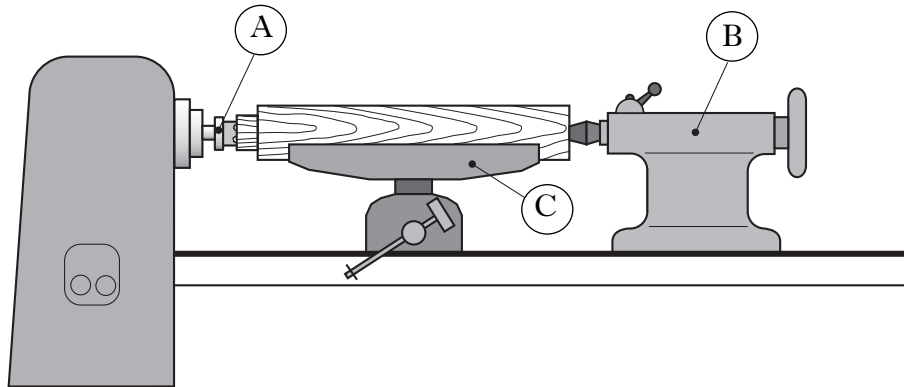

From the list below select the name of parts (A), (B) and (C).

Revolving centre Tailstock Headstock Fork centre Tool rest

(i) Part (A) _____

(ii) Part (B) _____

(iii) Part (C) _____

1
0

1
0
1
0
1
0

5. (continued)

- (c) State **two** safety checks which should be made to the wood lathe before switching it on.

1 _____

1
0

2 _____

1
0

- (d) The edges of the base were chamfered. State the name of a hand tool used to chamfer the edges.

1
0

- (e) The wooden base was varnished. State **two** stages in the preparation of the base before applying the varnish.

Stage 1 _____

1
0

Stage 2 _____

1
0

[Turn over

6. A school enterprise group made table mats from contrasting strips of wood as shown below.

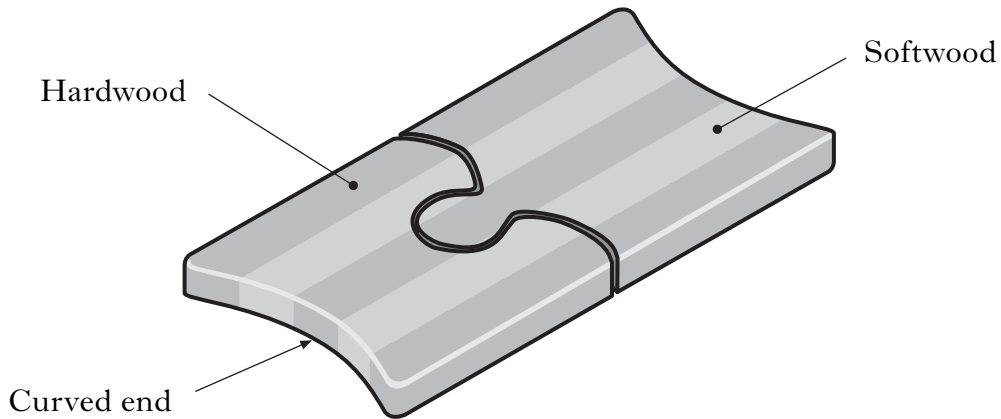

- (a) A list of materials is given below.

Hardboard Pine Plywood Beech Blockboard

From the list select:

(i) a hardwood; _____

(ii) a softwood. _____

- (b) One stage in the manufacture of the mat is shown.

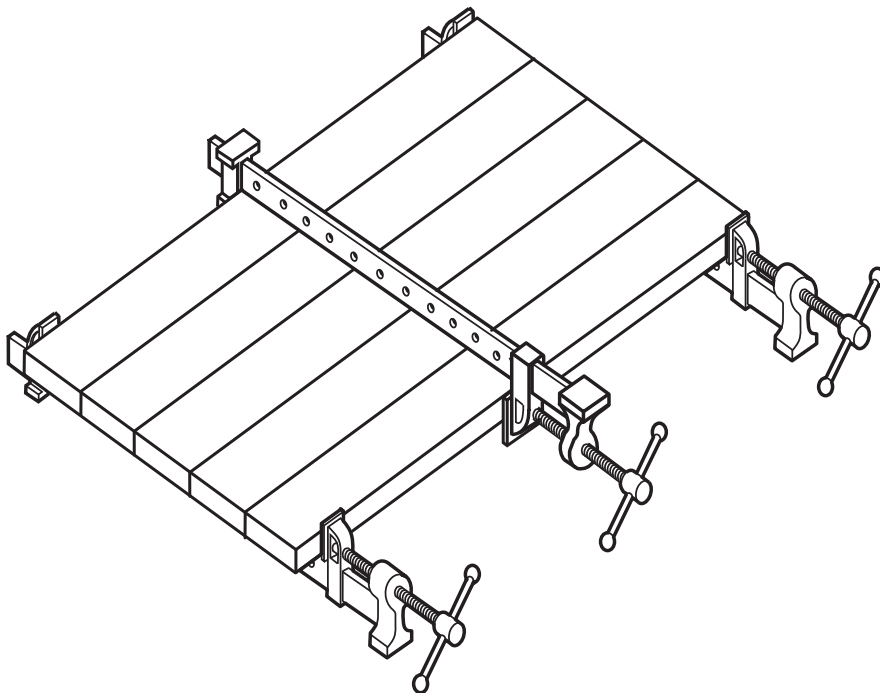

- (i) State the name of a suitable wood glue.

1
0
1
0

1
0

6. (b) (continued)

- (ii) The holding device shown below was used to hold the strips while the glue dried.

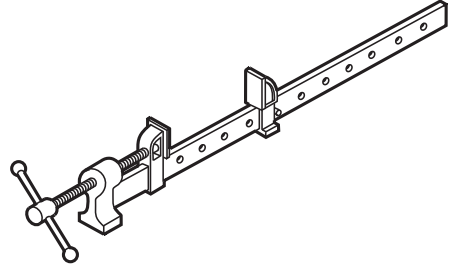

State the name of this device. _____

1
0

- (c) A number of mats were produced for sale.

State **two** advantages of using a template to mark out the curved ends.

1 _____

1
0

2 _____

1
0

- (d) State the name of a **machine** tool and a **hand** tool suitable for cutting out the curved ends.

(i) Machine tool _____

1
0

(ii) Hand tool _____

1
0

[END OF QUESTION PAPER]

[BLANK PAGE]

[BLANK PAGE]

[BLANK PAGE]