



Group Award Specification for:

**National Progression Award in Digital Literacy at
SCQF level 3**

Group Award Code: GL06 43

Validation date: September 2015

Date of original publication: October 2015

Version: 01

Contents

1	Introduction	1
2	Qualification(s) structure.....	3
	2.1 Structure.....	3
3	Aims of the qualification(s)	3
	3.1 General aims of the qualification(s)	3
	3.2 Specific aims of the qualification(s).....	4
4	Recommended entry to the qualification(s)	4
	4.1 Core Skills entry profile.....	4
5	Additional benefits of the qualification in meeting employer needs	4
	5.1 Mapping of qualification aims to Units	5
	5.2 Mapping of National Occupational Standards (NOS) and/or trade body standards	6
	5.3 Mapping of Core Skills development opportunities across the qualification(s)	7
	5.4 Assessment Strategy for the qualification(s)	8
6	Guidance on approaches to delivery and assessment.....	10
	6.1 Sequencing/integration of Units	10
	6.2 Recognition of Prior Learning	10
	6.2.1 Articulation and/or progression	11
	6.2.2 Professional recognition.....	11
	6.3 Opportunities for e-assessment.....	11
	6.4 Support materials	12
	6.5 Resource requirements	12
7	General information for centres	12
8	Glossary of terms	13
9	General information for learners.....	15

1 Introduction

This document was previously known as the Arrangements document. The purpose of this document is to:

- ◆ assist centres to implement, deliver and manage the qualification
- ◆ provide a guide for new staff involved in offering the qualification
- ◆ inform course managers teaching staff, assessors, learners, employers and HEIs of the aims and purpose of the qualification
- ◆ provide details of the range of learners the qualification is suitable for and progression opportunities

This Group Award Specification provides an update to the original NPA in Digital Literacy at SCQF level 3 first produced in July 2007. On review of the original 2007 qualification, the decision was taken to revamp the qualification and include two new Units and use one existing Unit from the SQA portfolio.

The structure of the new qualification is designed to reflect contemporary computing, especially new trends in computer hardware and software, social media, the Internet, mobile technologies, and computer applications, as well as how these technologies can be used safely and effectively for everyday purposes. The following diagram provides an overview of each of the Units and how they contribute to the overall award.

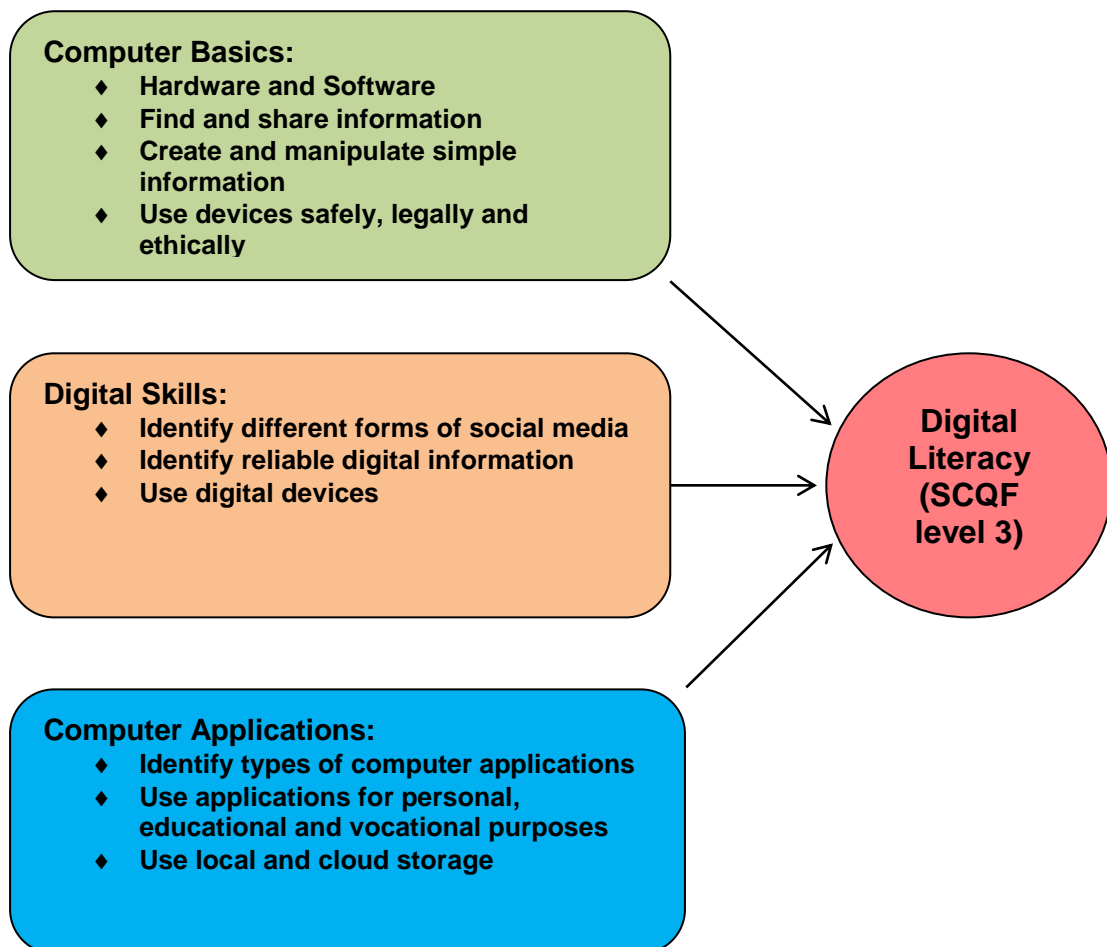

This qualification is designed as an introductory award, where learners with little or no experience of digital technologies and computing are able to achieve a basic understanding of technology in everyday contexts. The range of basic skills offered through this award provide an ideal grounding for learners to progress to other awards, such as NPA Digital Passport and NPA PC Passport, both at SCQF level 4. The diagram below provides detail of the progression routes from NPA Digital Literacy SCQF level 3.

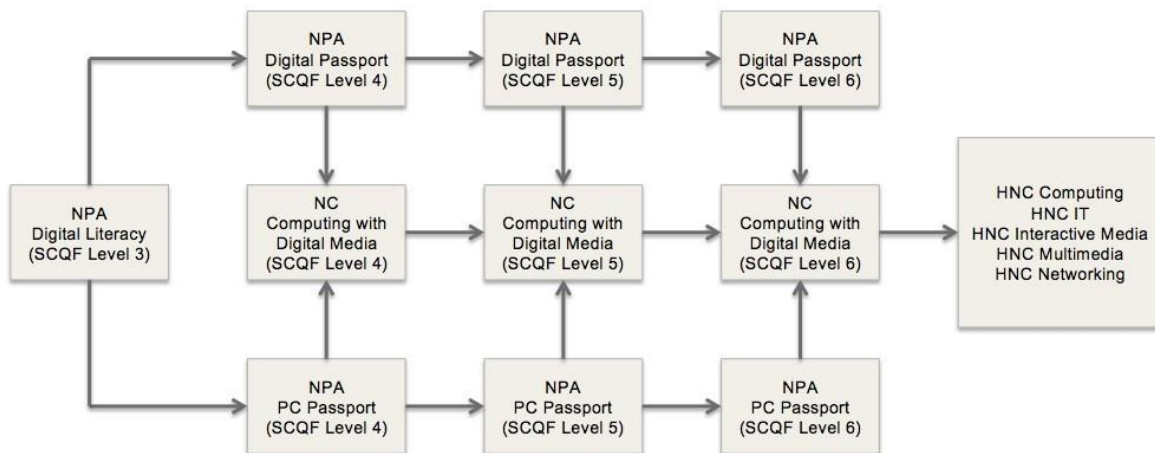

For the NPA Digital Literacy, each of the Units must be undertaken on a mandatory basis. Each Unit however may be undertaken individually on a stand-alone basis. The qualification is aimed at a wide range of learners, for example, young people in secondary school contexts through to adult returners and mature learners in the community. As well as gaining skills in digital technologies, learners also have the opportunity to develop Core Skills at various stages throughout the award.

Progression to employment may present itself to the learner on completion of the qualification, as learners will have gained the basic rounded skills relevant to the world of business and employment. On completion of the qualification, learners will have gained the digital skills needed for jobs that require basic IT competency. This qualification will also be useful for those working in a community context, where community learners are required to learn basic digital skills in order to gain a foothold on the current job market.

There are opportunities to develop Core Skills in the areas of *Numeracy*, *Communications*, *ICT* and *Problem Solving*.

2 Qualification(s) structure

This Group Award is made up of 3 SQA credits. It comprises 18 SCQF credit points of which 18 are at SCQF level 3 in the mandatory section.

SCQF level Descriptors were used to develop the component Units. SCQF level 3 is exemplified by Access 3 (previously Standard Grade at Foundation level) qualifications. Qualifications at SCQF level 3 should exhibit the following characteristics:

- ◆ basic knowledge of the subject area
- ◆ simple facts and ideas
- ◆ basic, routine skills
- ◆ carry out simple tasks
- ◆ use basic tools safely and effectively
- ◆ work in familiar contexts.

The components Units exhibit these characteristics.

A mapping of Core Skills development opportunities is available in Section 5.3.

2.1 Structure

4 code	2 code	Unit title	SCQF level	SCQF credit points	SQA credit
H9PV	43	Computer Applications	3	6	1
H3LJ	09	Computer Basics	3	6	1
H9PT	43	Digital Skills	3	6	1

3 Aims of the qualification(s)

The aim of the NPA in Digital Literacy is to provide an introductory award that will help learners to develop basic knowledge, understanding and awareness of modern digital technologies and the organisation of information. This includes computer and handheld/mobile device technology, tools and techniques of the Internet and computer applications, whilst being given the opportunity to develop communication and numeracy Core Skills.

3.1 General aims of the qualification(s)

The general aims of the NPA in Digital Literacy are:

- 1 To develop a range of digital skills to permit learners to use a range of contemporary digital devices.
- 2 To provide under-pinning knowledge to permit learners to adapt and update their skills as technologies evolve.
- 3 To enable learners to become confident and effective users of digital technologies.
- 4 To permit learners to participate in contemporary society and become good e-citizens.
- 5 To develop a range of digital skills to improve employability.
- 6 To develop Core Skills in different contexts as they progress through the award.
- 7 To provide an opportunity for learners to progress to further qualifications in Computing.

3.2 Specific aims of the qualification(s)

The three distinct Units: Computer Basics; Digital Skills and Computer Applications, provide the opportunity for learners to:

- 8 Learn about the hardware and software components of computers and handheld/smart devices.
- 9 Find, organise, manipulate and share digital information for personal, educational and vocational purposes using computers and/or handheld/smart devices.
- 10 Learn about the basics of computer networks.
- 11 Use computers and handheld/smart devices safely, legally and ethically for personal, educational and vocational purposes.
- 12 Create a safe and responsible online presence using communication tools and social media.
- 13 Describe and use different types of computer application packages for personal, educational and vocational purposes.
- 14 Develop Core Skills in the areas of communications, *ICT*, *Numeracy* and *Problem Solving*.
- 15 Provide an opportunity for learners to progress in to the NPA Digital Passport or PC Passport at SCQF level 4 or potential employment.

4 Recommended entry to the qualification(s)

This is an entry-level/introductory award and learners need not possess any prior SQA qualifications before entering on to NPA Digital Literacy. Entry to the qualification is at the discretion of the centre.

4.1 Core Skills entry profile

Learners are required to have a certain level of general education to have a realistic prospect of succeeding in the award.

Core Skills	Level
Communications	SCQF level 2
Numeracy	SCQF level 2
Information and Communication Technology (ICT)	SCQF level 2
Problem Solving	SCQF level 2
Working with Others	SCQF level 2

Please note that this is for guidance only. Entry to the award is at the discretion of the centre.

5 Additional benefits of the qualification in meeting employer needs

This qualification was designed to meet a specific purpose and what follows are details on how that purpose has been met through mapping of the Units to the aims of the qualification. Through meeting the aims, additional value has been achieved by linking the Unit standards with those defined in National Occupational Standards and/or trade/professional body requirements. In addition, significant opportunities exist for learners to develop the more generic skill, known as Core Skills through doing this qualification.

5.1 Mapping of qualification aims to Units

Code	Unit title	Aims														
		1	2	3	4	5	6	7	8	9	10	11	12	13	14	15
H3LJ 09	Computer Basics	x	x	x	x	x	x	x	x	x		x	x	x	x	x
H9PT 43	Digital Skills	x	x	x	x	x	x	x	x	x	x	x	x		x	x
H9PV 43	Computer Applications		x	x		x	x	x		x				x	x	x

5.2 Mapping of National Occupational Standards (NOS) and/or trade body standards

Due to the level and subject area, there is no relevant NOS directly linked to this qualification.

There are however indirect relationships to The Tech Partnership (formerly e-skills) National Occupational Standards for:

ESKIIUF2	IT User Fundamentals
ESKIICF1	IT Communications Fundamentals
ESKIUMD1	Using mobile IT Devices
ESKITU010	Source digital information
ESKITU011	Organise Digital Information
ESKITU060	Use IT Applications to Improve Productivity

5.3 Mapping of Core Skills development opportunities across the qualification(s)

The following table shows where each of the Units can contribute to Core Skills.

Core Skills can be delivered within an award by **embedding** ('E') them (in which case the award will lead to additional certification for learners' Core Skills) or **signposting** ('S') them (which does not lead to certification).

Unit code	Unit title	Communication		Numeracy		ICT		Problem Solving			Working with Others	
		Written	Oral	Using Number	Using Graphical Information	Accessing Information	Providing/Creating Information	Critical Thinking	Planning and Organising	Reviewing and Evaluating	Working Co-operatively with Others	Reviewing Co-operative Contribution
H3LJ 09	Computer Basics					S3	S3					
H9PT 43	Digital Skills	S3				E2	E2		S3			
H9PV 43	Computer Applications	S3		S3		E3	E3					

5.4 Assessment Strategy for the qualification(s)

In most Units, the Evidence Requirements take a holistic approach to the generation of evidence to show competence by requiring two items of evidence. These are:

- 1 evidence of cognitive competence (knowledge and understanding).
- 2 evidence of practical competence (practical abilities).

The Support Notes provide guidance on the instruments of assessment that could be used to generate the evidence (in the section entitled 'Guidance on Approaches to Assessment').

The following table summarises this guidance (and is not mandatory). Alternative forms of assessment are acceptable so long as they satisfy the Evidence Requirements for each Unit. In most cases, the suggested approach to assessment combines all of the knowledge into one assessment and all of the practical skills into one assessment.

Unit		Assessment		
		Outcome 1	Outcome 2	Outcome 3
H3LJ 09	Computer Basics	Written and/or oral evidence Closed-book Group discussion	Practical tasks Open-book	
		Portfolio of evidence (including e-portfolio, eg web log)		
H9PV 43	Computer Applications	Written and/or oral evidence Closed-book (all Performance Criteria) Group discussion	Written and/or oral evidence Closed-book (Performance Criteria (a)) Practical tasks Group discussion Open-book (Performance Criteria (b), (c), (d), (e))	Written and/or oral evidence Closed-book (Performance Criteria (a), (b), (c)) Group discussion Practical tasks Open-book (Performance Criteria (d), (e))

Unit		Assessment		
		Outcome 1	Outcome 2	Outcome 3
H9PT 43	Digital Skills	Written and/or oral evidence Closed-book (all Performance Criteria) Group discussion	Written and/or oral evidence Closed-book (all Performance Criteria) Group discussion	Written and/or oral evidence Closed-book (Performance Criteria (a), (b)) Group discussion Practical tasks Open-book (Performance Criteria (c), (d), (e))

6 Guidance on approaches to delivery and assessment

The delivery and assessment of this qualification aims to be as open and flexible as possible, given the different contexts in which it is likely to be delivered.

The qualification aims to introduce basic aspects of computing to learners: computer hardware and software; computer applications; handheld and mobile technology; social media (and its safe and proper use) and the basics of computer networking.

There are different ways in which the award can be delivered and assessed. It is recommended however that learners are assessed on their cognitive and practical abilities. For example, learners entering onto the award may already be comfortable with using handheld/mobile devices and social media. In this scenario, assessors may wish to complete checklists that demonstrate the practical abilities of the learners. Cognitive abilities — or knowledge and skills — may be recorded using short multiple choice quizzes.

Another method may be for assessors to use a more holistic approach, where learners work from a case study or scenario, and submit evidence into an ePortfolio system as they progress through the award.

6.1 Sequencing/integration of Units

It is advised that the *Computer Basics* Unit be the first to be delivered within the award. This Unit provides learners with the foundation knowledge in computer hardware and software as well as information handling skills, both of which are expanded upon in the subsequent Units. Centres should decide for themselves, which of the two Units should follow *Computer Basics*.

The timetable of delivery and assessment is at the discretion of the centre, however it is recommended that more time be given for the practical aspects of this award. For each of the Units, practical tasks can be assessed on an on-going basis throughout the duration of each of the Units. Knowledge and skills can perhaps be measured near the end of each of the Units.

There is distinct overlap between some of the Outcomes (and related Performance Criteria) throughout each of the Units that may allow centres to integrate some of the Units, and deliver the award on a more holistic basis.

6.2 Recognition of Prior Learning

SQA recognises that learners gain knowledge and skills acquired through formal, non-formal and informal learning contexts.

In some instances, a full Group Award may be achieved through the recognition of prior learning. However, it is unlikely that a learner would have the appropriate prior learning and experience to meet all the requirements of a full Group Award.

The recognition of prior learning may **not** be used as a method of assessing in the following types of Units and assessments:

- ◆ HN Graded Units
- ◆ Course and/or external assessments
- ◆ Other integrative assessment Units (which may or not be graded)
- ◆ Certain types of assessment instruments where the standard may be compromised by not using the same assessment method outlined in the Unit
- ◆ Where there is an existing requirement for a licence to practice
- ◆ Where there are specific health and safety requirements
- ◆ Where there are regulatory, professional or other statutory requirements
- ◆ Where otherwise specified in an Assessment Strategy

More information and guidance on the *Recognition of Prior Learning* (RPL) may be found on our website www.sqa.org.uk.

The following sub-sections outline how existing SQA Unit(s) may contribute to this Group Award. Additionally, they also outline how this Group Award may be recognised for professional and articulation purposes.

6.2.1 Articulation and/or progression

This is an entry level qualification designed for individuals with little or no computing/digital skills. The qualification is also designed as a pathway into higher level National Progression Awards at SCQF level 4, such as the NPA PC Passport and NPA Digital Passport. Please refer to the diagram in Section 1 of the different routes that can be taken from this award to level 4 NPAs (and beyond).

There is no articulation from this award to university degree programmes.

6.2.2 Professional recognition

There is no professional recognition that can be gained from this award.

6.3 Opportunities for e-assessment

Given the 'digita' nature and aspects of this award, there may be opportunities for elements of the program to be delivered by e-learning and e-assessment. Practitioners may choose to use the functions of traditional Virtual Learning Environments (VLEs) for the delivery of class resources and for collaborative engagement. Similarly, there may be opportunities for practitioners to engage with learners through the use of social media.

E-assessment opportunities may arise for this Unit through the use of, for example, multiple choice quizzes that can be used to capture knowledge and skills (or cognitive abilities) that are associated with each of the Units. Tutors wishing to employ a more holistic assessment process may do so through the use of ePortfolios that can be used to capture evidence as learners progress through the Units.

6.4 Support materials

An existing Assessment Support Pack (ASP) for the *Computer Basics* Unit is available to view on SQA's secure site. ASPs will be produced for *Computer Applications* and *Digital Skills*. The support packs will provide detailed assessment guidelines and advice as well as exemplars of valid evidence.

6.5 Resource requirements

Centres offering this award are advised to have tutors that are knowledgeable in the general areas of computing, including computer applications, computer hardware and software. More specialist knowledge may be required for teaching in the areas of handheld/mobile technology, wireless and wired network technology, social media and cloud computing. Tutors delivering the social media aspects of this award are advised to have good awareness of how social media can be used safely and responsibly, as well as the issues that can arise with using social media in the classroom.

There are technical resource implications for centres in that PCs, laptops, tablets, mobile/handheld technology and identified software will have to be made available to learners in order to complete particular Outcomes on the award.

When using local and cloud storage, there is recognition that not all centres will have access to cloud storage, for example, due to firewall restrictions. In this case, centres may wish to simulate cloud storage by using, for example, shared network drives. Local storage may refer to storage already attached to devices, for example, internal storage, memory cards, USB sticks and so on.

7 General information for centres

Equality and inclusion

The Unit specifications making up this Group Award have been designed to ensure that there are no unnecessary barriers to learning or assessment. The individual needs of learners will be taken into account when planning learning experiences, selecting assessment methods or considering alternative evidence. Further advice can be found on our website www.sqa.org.uk/assessmentarrangements.

Internal and external verification

All instruments of assessment used within this/these qualification(s) should be internally verified, using the appropriate policy within the centre and the guidelines set by SQA.

External verification will be carried out by SQA to ensure that internal assessment is within the national guidelines for these qualifications.

Further information on internal and external verification can be found in *SQA's Guide to Assessment* (www.sqa.org.uk/GuideToAssessment).

8 Glossary of terms

Embedded Core Skills: is where the assessment evidence for the Unit also includes full evidence for complete Core Skill or Core Skill components. A learner successfully completing the Unit will be automatically certificated for the Core Skill. (This depends on the Unit having been successfully audited and validated for Core Skills certification.)

Finish date: The end of a Group Award's lapsing period is known as the finish date. After the finish date, the Group Award will no longer be live and the following applies:

- ◆ candidates may not be entered for the Group Award
- ◆ the Group Award will continue to exist only as an archive record on the Awards Processing System (APS)

Lapsing date: When a Group Award is entered into its lapsing period, the following will apply:

- ◆ the Group Award will be deleted from the relevant catalogue
- ◆ the Group Award specification will remain until the qualification reaches its finish date at which point it will be removed from SQA's website and archived
- ◆ no new centres may be approved to offer the Group Award
- ◆ centres should only enter candidates whom they expect to complete the Group Award during the defined lapsing period

SQA credit value: The credit value allocated to a Unit gives an indication of the contribution the Unit makes to an SQA Group Award. An SQA credit value of 1 given to an SQA Unit represents approximately 40 hours of programmed learning, teaching and assessment.

SCQF: The Scottish Credit and Qualification Framework (SCQF) provides the national common framework for describing all relevant programmes of learning and qualifications in Scotland. SCQF terminology is used throughout this guide to refer to credits and levels. For further information on the SCQF visit the SCQF website at www.scqf.org.uk.

SCQF credit points: SCQF credit points provide a means of describing and comparing the amount of learning that is required to complete a qualification at a given level of the Framework. One National Unit credit is equivalent to 6 SCQF credit points. One National Unit credit at Advanced Higher and one Higher National Unit credit (irrespective of level) is equivalent to 8 SCQF credit points.

SCQF levels: The level a qualification is assigned within the framework is an indication of how hard it is to achieve. The SCQF covers 12 levels of learning. HNCs and HNDs are available at SCQF levels 7 and 8 respectively. Higher National Units will normally be at levels 6–9 and Graded Units will be at level 7 and 8. National Qualification Group Awards are available at SCQF levels 2–6 and will normally be made up of National Units which are available from SCQF levels 2–7.

Subject Unit: Subject Units contain vocational/subject content and are designed to test a specific set of knowledge and skills.

Signposted Core Skills: refers to opportunities to develop Core Skills arise in learning and teaching but are not automatically certificated.

History of changes

It is anticipated that changes will take place during the life of the qualification and this section will record these changes. This document is the latest version and incorporates the changes summarised below. Centres are advised to check SQA's APS Navigator to confirm they are using the up to date qualification structure.

NOTE: Where a Unit is revised by another Unit:

- ◆ No new centres may be approved to offer the Unit which has been revised.
- ◆ Centres should only enter candidates for the Unit which has been revised where they are expected to complete the Unit before its finish date.

Version Number	Description	Date

Acknowledgement

SQA acknowledges the valuable contribution that Scotland's centres have made to the development of this qualification.

9 General information for learners

This section will help you decide whether this is the qualification for you by explaining what the qualification is about, what you should know or be able to do before you start, what you will need to do during the qualification and opportunities for further learning and employment.

The NPA Digital Literacy (level 3) qualification is an award that aims to introduce you to the fundamentals of computers, computer applications, digital information and the digital skills that are needed in order for you to understand how these technologies relate to each other. The award also aims to introduce you to more specific elements like information literacy skills and as well as social media and computer networks and how they can be used safely and responsibly. The award is specifically aimed at individuals with little or no computing skills. The award consists of the following Units:

Computer Basics

This Unit designed to provide you with foundation knowledge in using a variety of devices, for example, PCs and mobile/handheld technology and how they can be used safely and responsibly. The Unit has four Outcomes:

- 1 Identify the hardware and software components of computing devices.
- 2 Find and share simple information using computing devices.
- 3 Create and manipulate simple information using computing devices.
- 4 Use computing devices safely, legally and ethically.

Digital Skills

This Unit is designed to introduce you to the more practical aspects of using PCs and mobile/handheld technologies and how they can be used in different contexts, for example, educational and personal uses. You will learn basic techniques in searching for and using information online as well as how to use social media safely and effectively. The Unit has three Outcomes:

- 1 Identify different forms of social media.
- 2 Identify reliable digital information.
- 3 Use digital devices.

Computer Applications

This Unit is designed to introduce you to the basics of computer application packages and how they can be used in a variety of ways, for example, for writing, counting and graphics/presentations and how they can be used safely and responsibly. The Unit also introduces the practical uses of local and cloud digital storage. The Unit has three Outcomes:

- 1 Identify the types of computer application packages and their common uses.
- 2 Use application packages to produce simple information for personal, educational and vocational purposes.
- 3 Use local and cloud storage.

Successful completion of this award will allow progression to SCQF level 4 awards such as NPA PC Passport and NPA Digital Passport. The qualification will also provide you with the necessary basic digital skills needed for jobs that require IT competencies.