

STAPLE HERE

FOR OFFICIAL USE

--	--	--	--	--	--

**X033/12/01**

NATIONAL  
QUALIFICATIONS  
2015

THURSDAY, 30 APRIL  
1.00 PM – 4.00 PM

GRAPHIC  
COMMUNICATION  
HIGHER

Fill in these boxes and read what is printed below.

Full name of centre

Town

Forename(s)

Surname

Date of birth

Day Month Year

--	--	--	--	--	--

Scottish candidate number

--	--	--	--	--	--	--	--	--	--

Number of seat

- 1 **140 Marks are allocated to this paper. Section A = 40 marks  
Section B = 100 marks**
- 2 Candidates should attempt **all** questions in **Section A** and are advised to spend approximately 45 minutes on this section. A supplementary page is included at the end of **Section A** for use if extra space is required.
- 3 Candidates should attempt questions 8, 9, 10, 11 and **either** question 12 **or** question 13 in **Section B**.
- 4 Read each question carefully before you answer.
- 5 Written answers may be in **ink** or **pencil**.
- 6 Drawings and sketches **must be in pencil**.
- 7 Dimensions are given in millimetres or as stated.
- 8 Orthographic drawings are in third angle projection.
- 9 **At the end of the examination**  
check that your name is on every sheet;  
put the sheets in correct numerical order;  
place this sheet on top of the others;  
join all sheets together by stapling at the top left-hand corner;  
before leaving the examination room, you must give these sheets to the Invigilator (if you do not you may lose all the marks for this paper).

Question	Marks
1	
2	
3	
4	
5	
6	
7	
Section A Total	

8	
9	
10	
11	
12	
13	
Section B Total	

EITHER

OR

<b>Total Marks A + B</b>	
----------------------------------	--



**[BLANK PAGE]**

**DO NOT WRITE ON THIS PAGE**

1

A supplementary page is included at the end of Section A for use if extra space is required.

Marks

A partially drawn CAD layout for a new photocopier control panel is shown in Figure 1 below. Figure 2 shows the completed design.

State the six single CAD commands that have been used to complete the finished design.

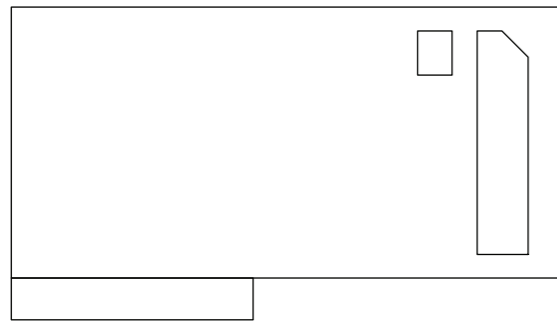

Figure 1

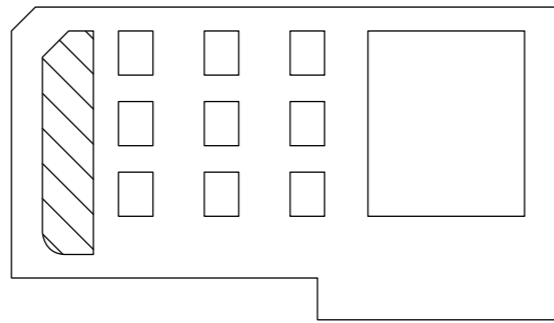

Figure 2

- CAD command ..... 1
- CAD command ..... 1
- CAD command ..... 1
- CAD command ..... 1
- CAD command ..... 1
- CAD command ..... 1

(6)

2

Section A

Describe the meaning of the following desktop publishing terms. Sketches may be used to aid description. Marks

(a) Gutter .....

.....  
.....  
.....

1

(b) Column Rule .....

.....  
.....  
.....

1

(c) Full Justification .....

.....  
.....  
.....

1

(d) Caption .....

.....  
.....  
.....

1

(e) Folio .....

.....  
.....  
.....

1

(5)

3

A pictorial view of part of a universal joint is shown below. Four sizes are given.

Marks

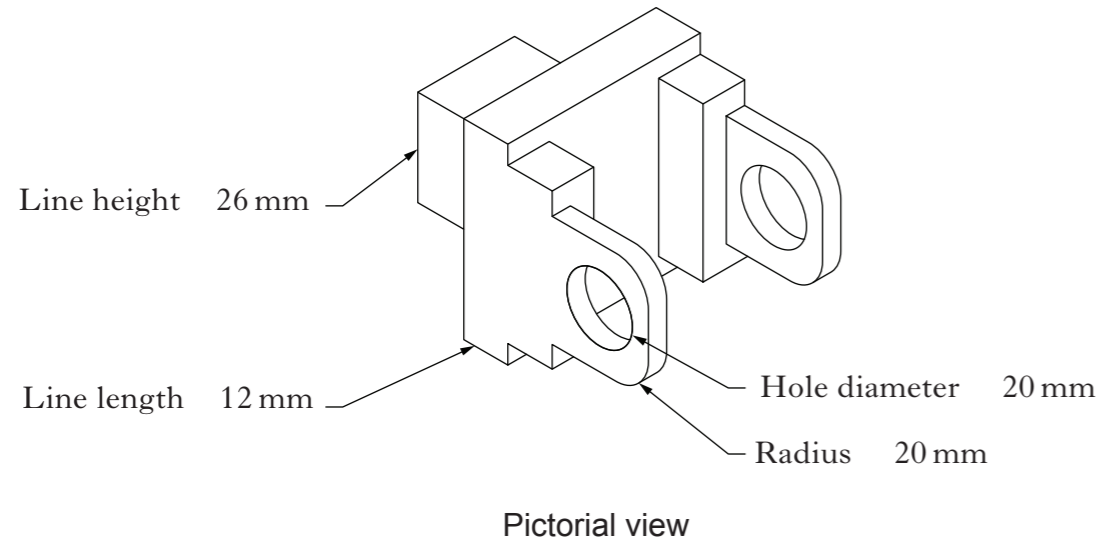

Sketch, the **four** given dimensions to **British Standards** conventions, on the elevation given below.

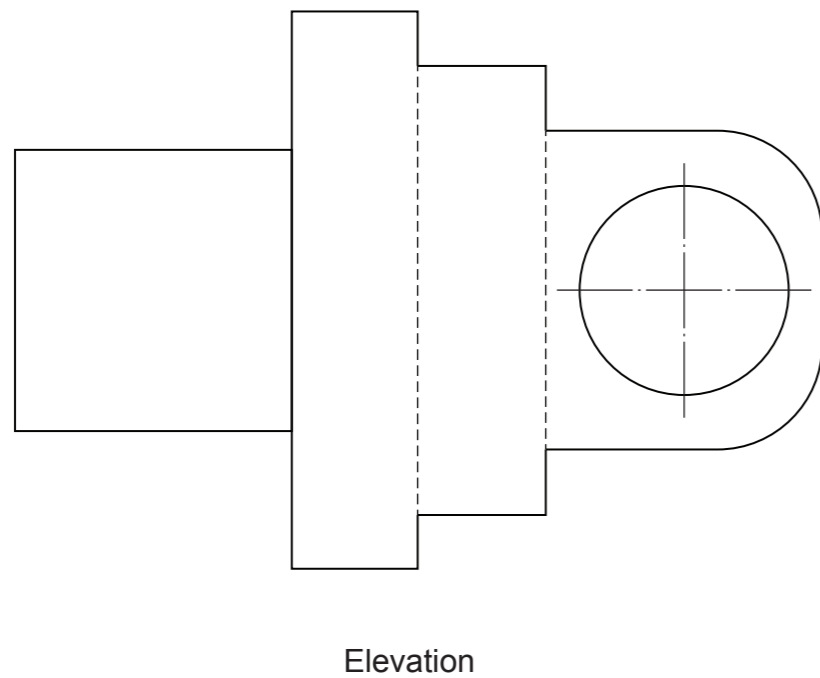

1

1

1

1

(4)

4

### Section A

Marks

(a) Two plans from the same building project are shown below. They are not to scale.

State, under each plan, the appropriate plan type and scale.

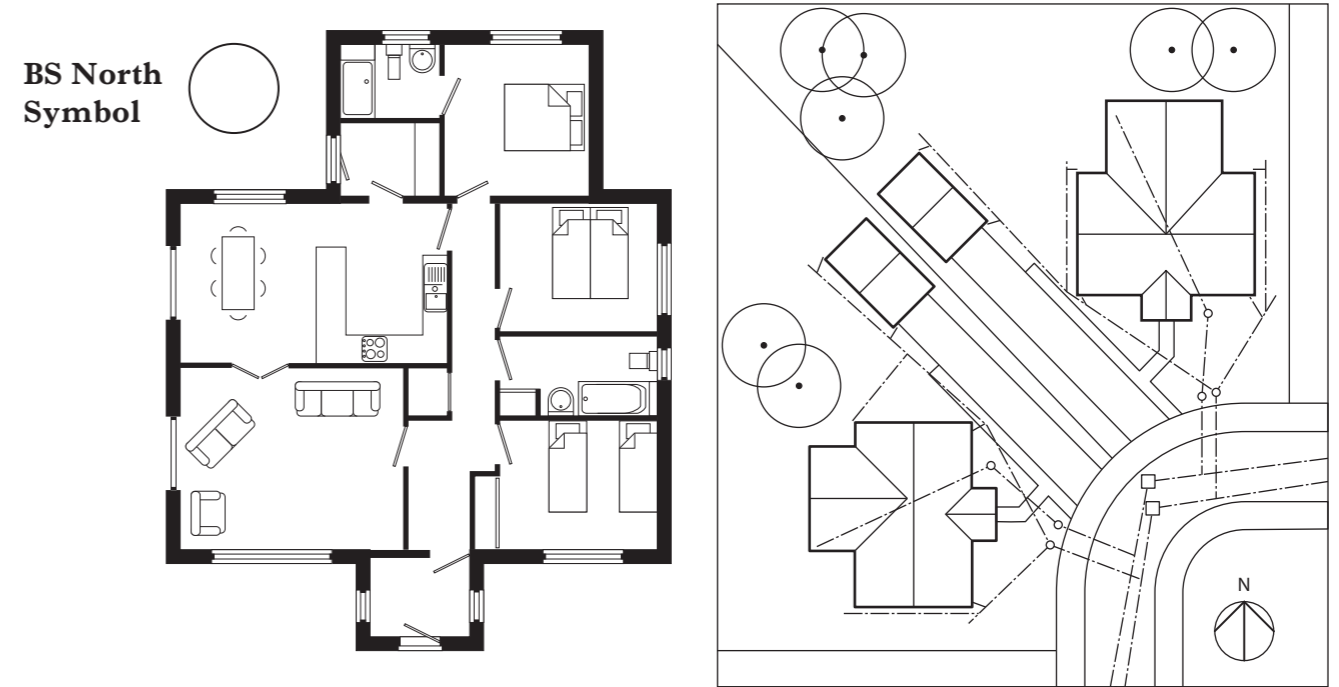

Plan Type ..... Plan Type .....

Scale ..... Scale ..... 2

(b) Complete the **BS North Symbol** on plan A in the correct orientation. 1

(c) Indicate the building location of Plan A on Plan B by shading it. 1

(d) Describe the computer-aided feature **layering**, with particular reference to how it could be used in Plan A above.

.....

.....

.....

.....

2

(6)

5

The types of graphic used in industry fall into three categories, Preliminary, Production and Promotional.

Explain the purpose and give an example of each type of graphic.

Preliminary

**Purpose** .....

.....

.....

1

**Example** .....

1

Production

**Purpose** .....

.....

.....

1

**Example** .....

1

Promotional

**Purpose** .....

.....

.....

1

**Example** .....

1

(6)

Marks

6

Illustration packages are widely used in the graphics industry, within these packages the terms tonal scale, colour gradient, tint and shade are used.

(a) Describe the difference between a **tonal scale** and a **colour gradient**.

.....

.....

.....

.....

1

(b) Describe the difference between a **tint** and a **shade**.

.....

.....

.....

.....

1

(2)

Marks

Section A

The Elevation and Sectional Plan of a caravan plug and title block are shown opposite, drawn to **British Standards**.

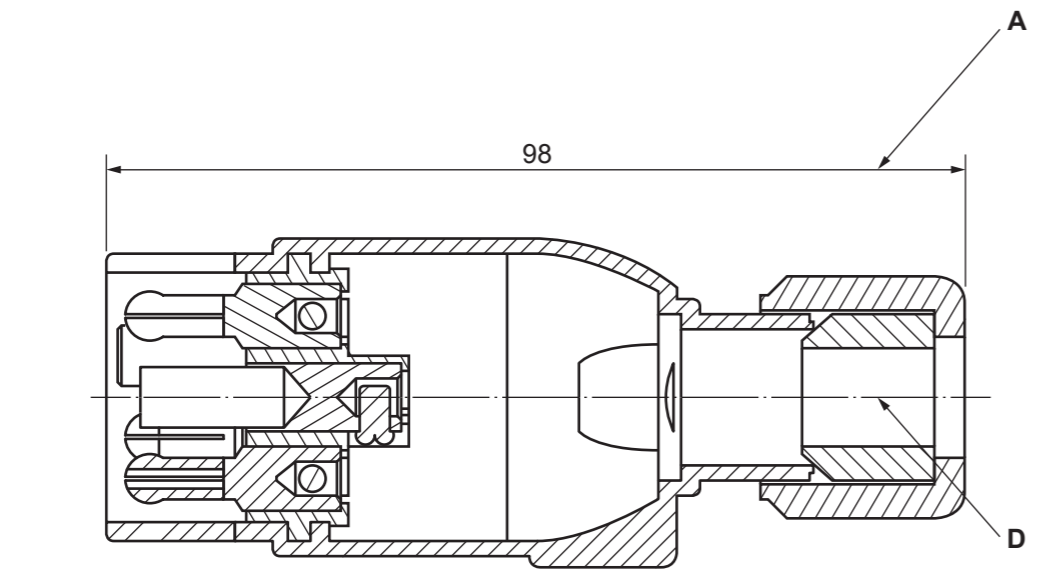

SECTIONAL PLAN ON A-A

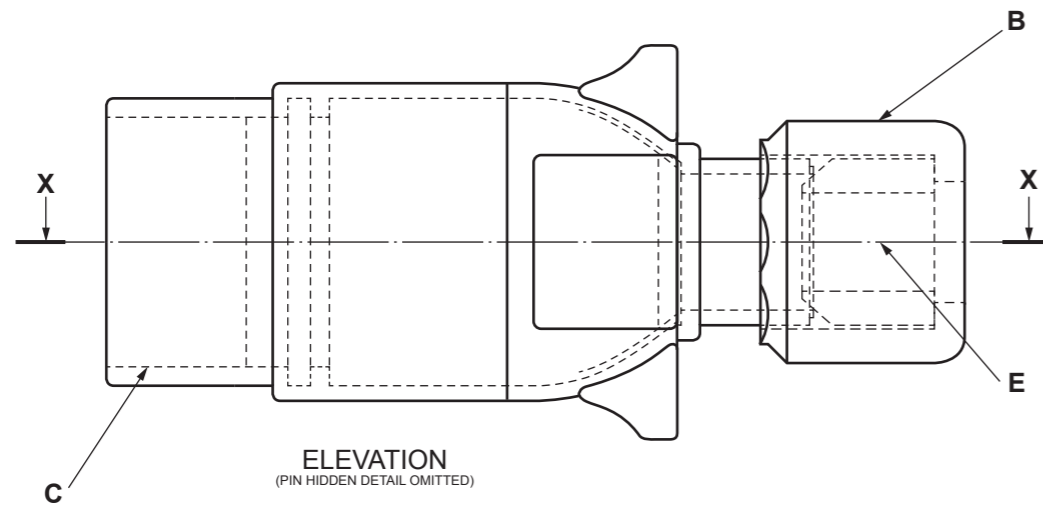

ELEVATION  
(PIN HIDDEN DETAIL OMITTED)

TITLE Block	
1	5
2	6
3	
4	

(a) The Third Angle Projection Symbol has been placed in the title block. State another six items of information that could be included in the title block to conform to **British Standards**.

- 1 ..... 1
- 2 ..... 1
- 3 ..... 1
- 4 ..... 1
- 5 ..... 1
- 6 ..... 1

(b) Five line types are indicated on the drawing opposite. Complete the table below giving either the description or the application of each line type.

Line	Description	Application
A	Continuous thin	
B		Visible outlines and edges
C		Hidden outline and edges
D	Chain thin	
E		Cutting planes

(11)

The elevation and plan of a torch are given.

**Draw** to the same scale and in the position indicated:

(a) the end elevation;

**Show all hidden detail.**

(b) the auxiliary plan.

**Do not show the hidden detail.**

(20 marks)

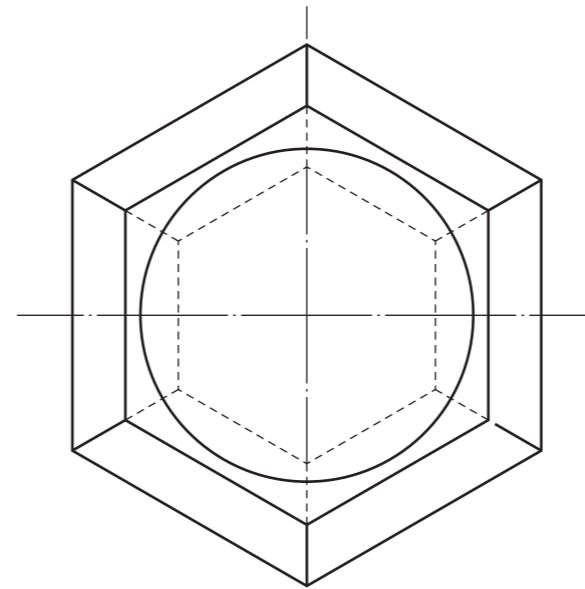

PLAN

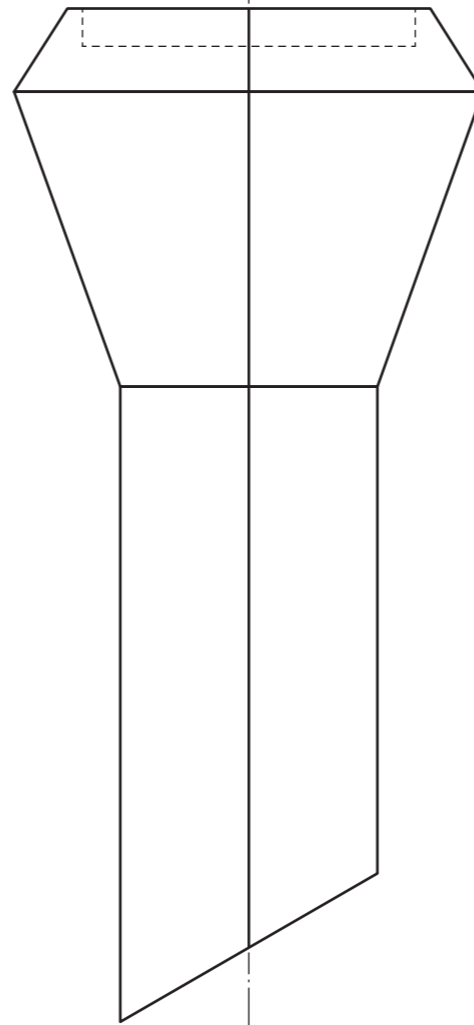

ELEVATION

END ELEVATION

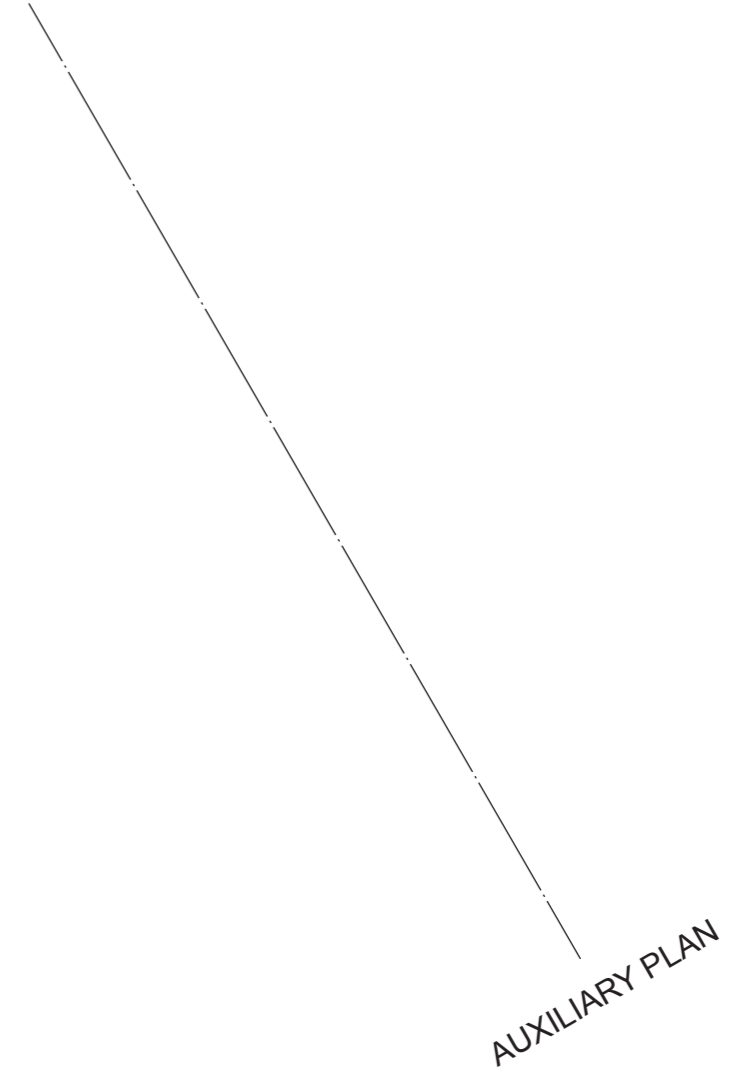

AUXILIARY PLAN

<i>a</i>	
<i>b</i>	
<i>c</i>	
<i>d</i>	
<i>e</i>	
<i>f</i>	
<i>g</i>	
<i>h</i>	
<i>i</i>	
<i>j</i>	
<i>k</i>	
<i>l</i>	
<i>m</i>	
<i>n</i>	

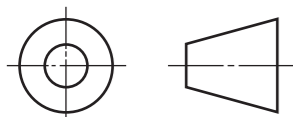

Orthographic views of the two parts that make up a bike lamp are given.

**Draw** an exploded isometric view of the two parts of the lamp

Use the given starts **X** and **Y**.

**Do not show hidden detail.**

(20 marks)

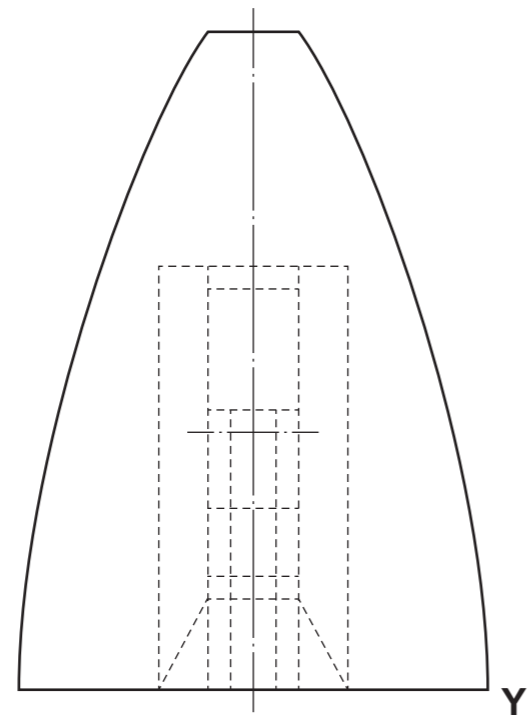

PLAN

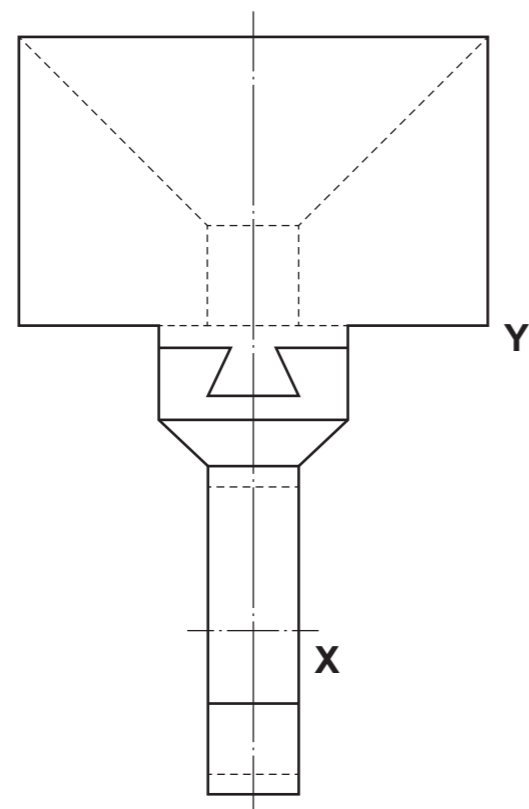
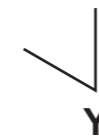

ELEVATION

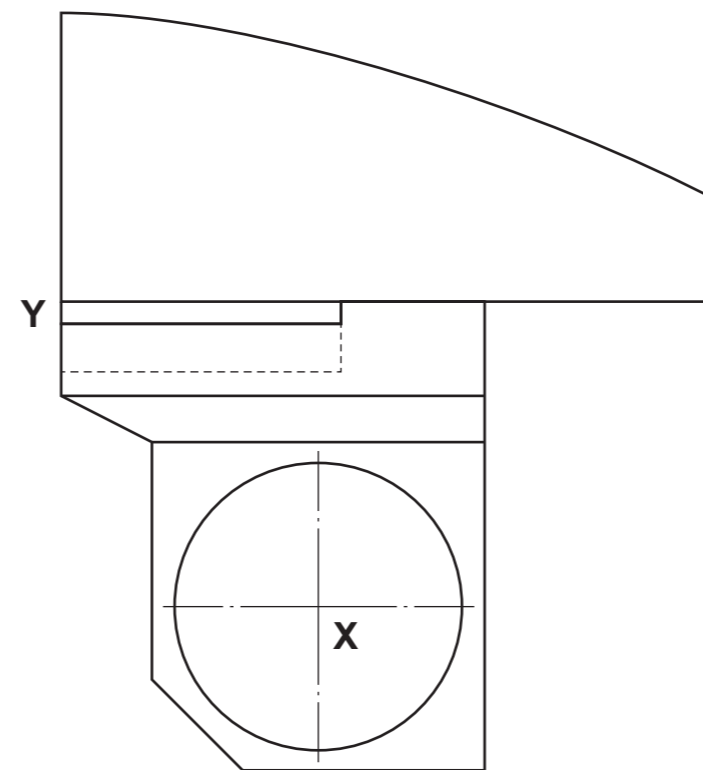

END ELEVATION

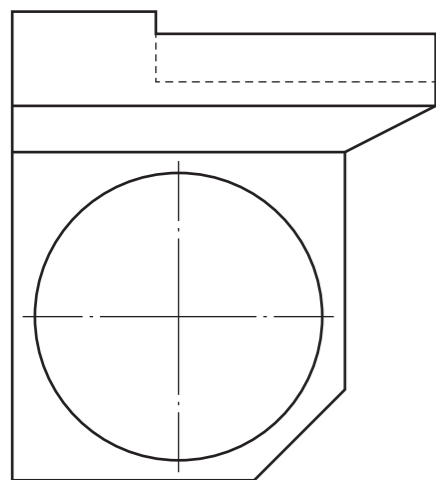

END ELEVATION OF BASE PART

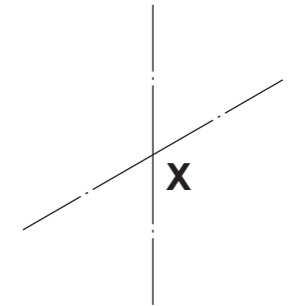

<i>a</i>	
<i>b</i>	
<i>c</i>	
<i>d</i>	
<i>e</i>	
<i>f</i>	
<i>g</i>	
<i>h</i>	
<i>i</i>	
<i>j</i>	
<i>k</i>	
<i>l</i>	
<i>m</i>	
<i>n</i>	

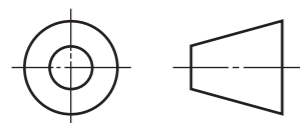



10

Section B 10

The plan and elevation of a down pipe and gutter are given. A sketch is also shown.

Draw in the positions indicated:

- (a) the end elevation;
- (b) the development of the pipe.

Show the hidden detail. Ignore the thickness of the material. (20 marks)

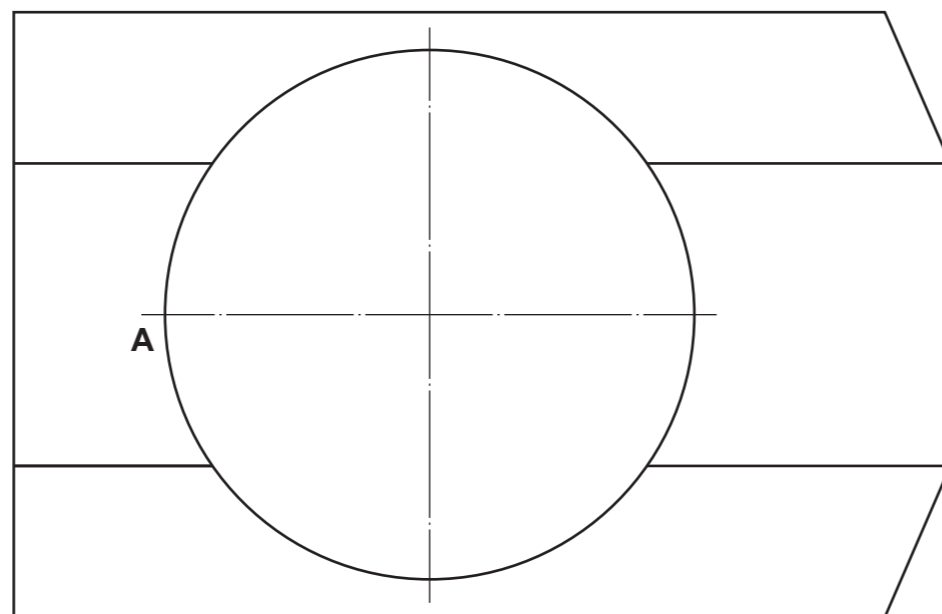
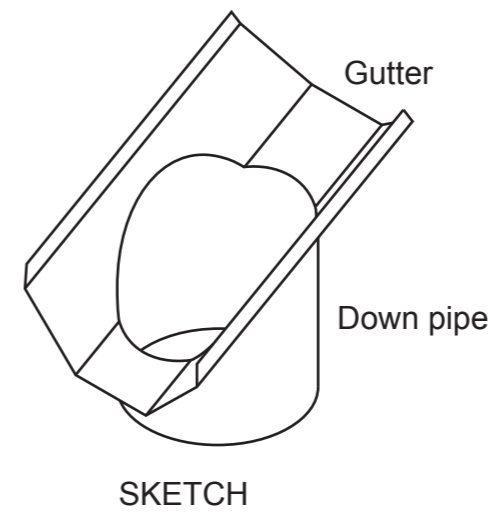

PLAN

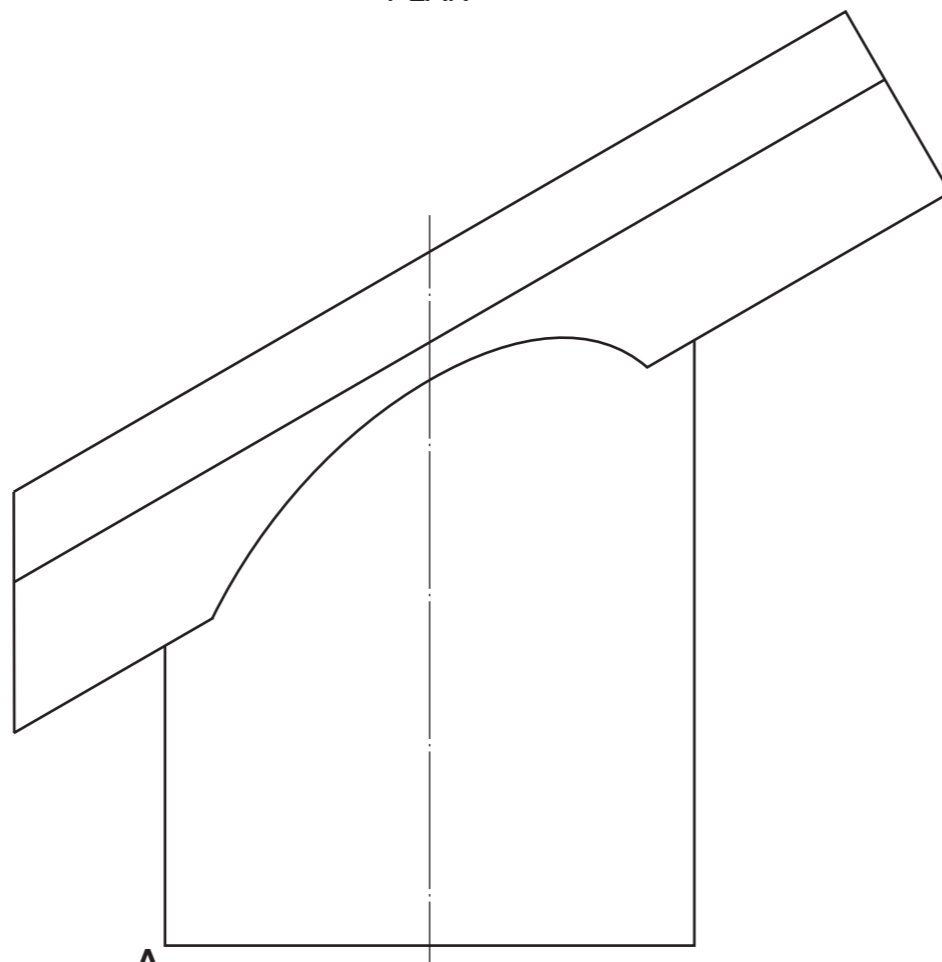

A

ELEVATION

END ELEVATION

DEVELOPMENT

<i>a</i>	
<i>b</i>	
<i>c</i>	
<i>d</i>	
<i>e</i>	
<i>f</i>	
<i>g</i>	
<i>h</i>	
<i>i</i>	
<i>j</i>	
<i>k</i>	
<i>l</i>	
<i>m</i>	
<i>n</i>	

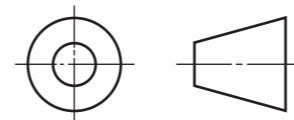
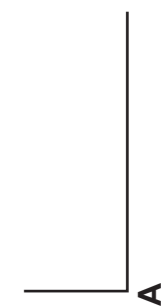

Candidate's Name \_\_\_\_\_

**DECK**

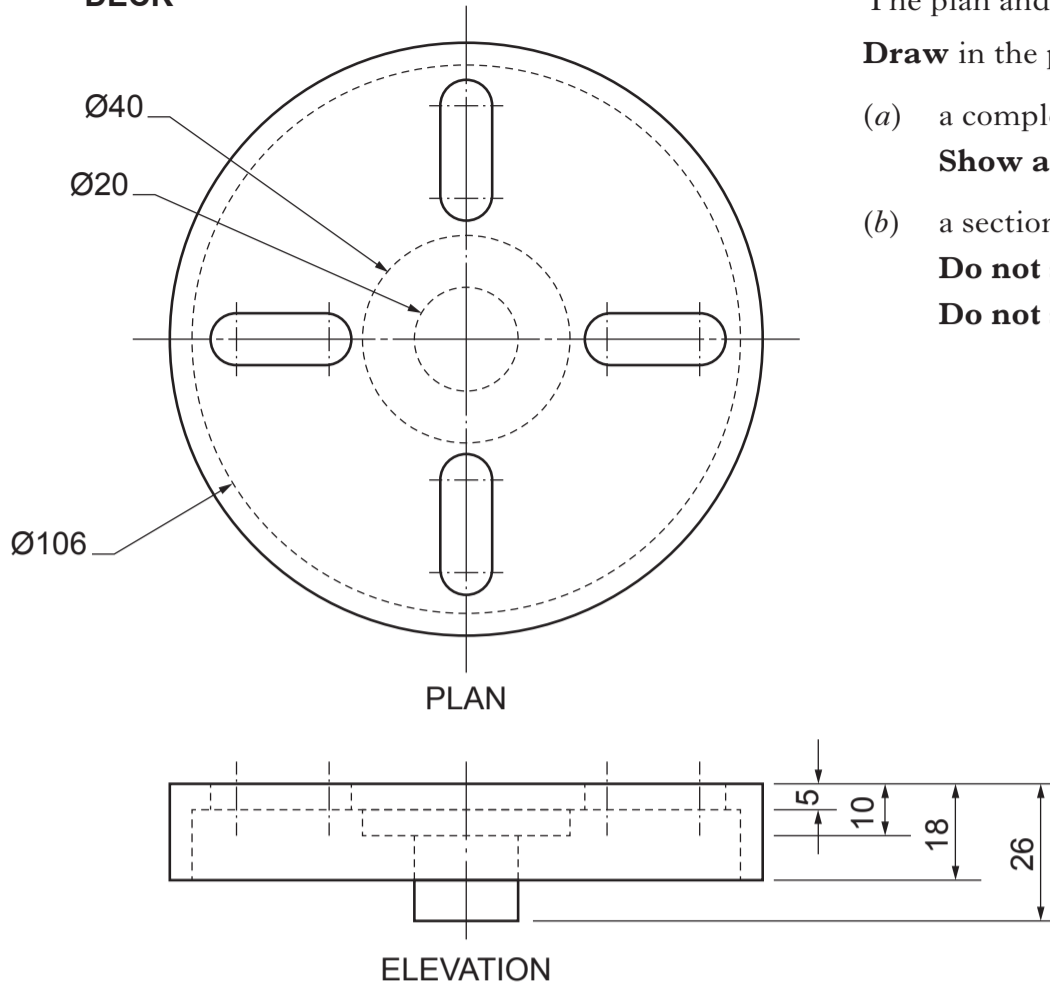

The plan and elevation of the four parts that make up a turntable are given.

**Draw** in the position indicated on **Worksheet 11**:

- (a) a complete plan of the assembled components;  
**Show all hidden detail.**
- (b) a sectional end elevation on **A-A**.  
**Do not show hidden detail.**  
**Do not section the adjustment screws.**

(20 marks)

**SPACER**

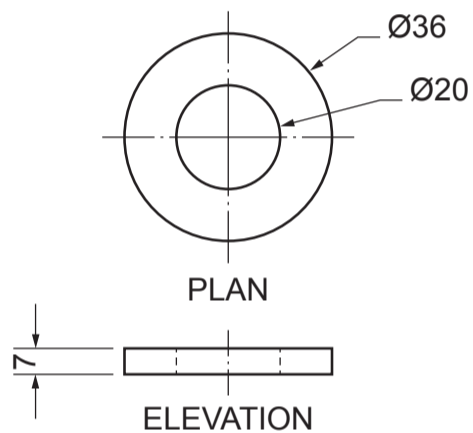

**NOT TO SCALE**

**SUPPORT FRAME**

**ENLARGED REMOVED SECTION on X-X**

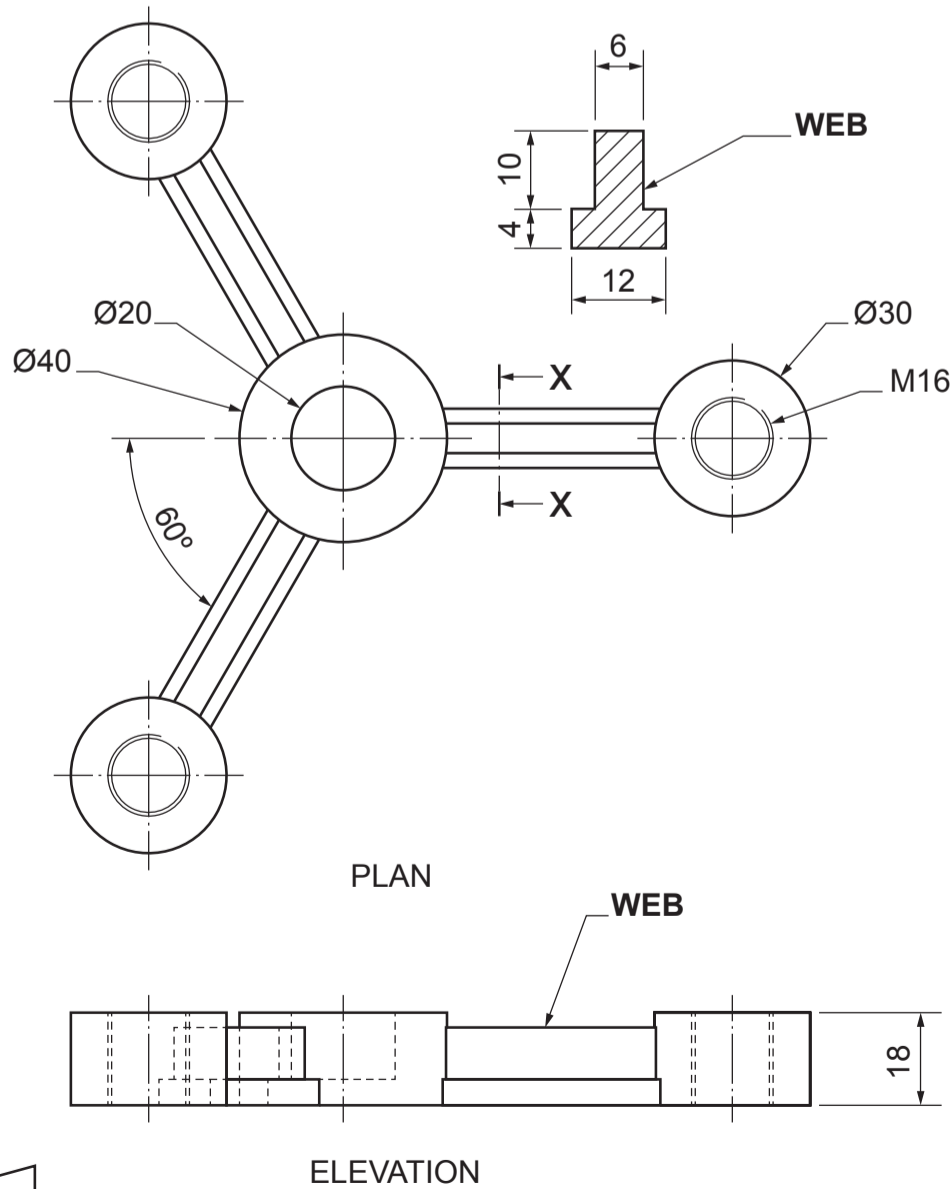

**ADJUSTMENT SCREW (3 OF)**

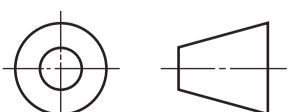
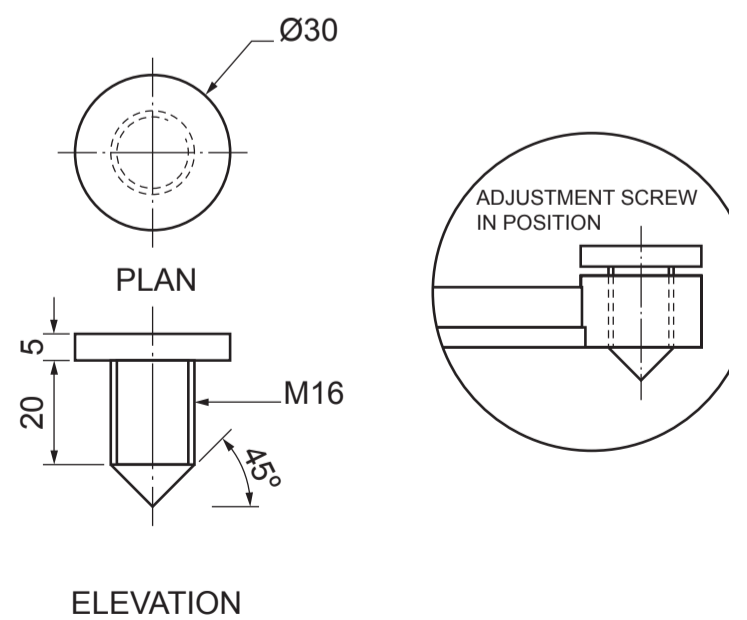

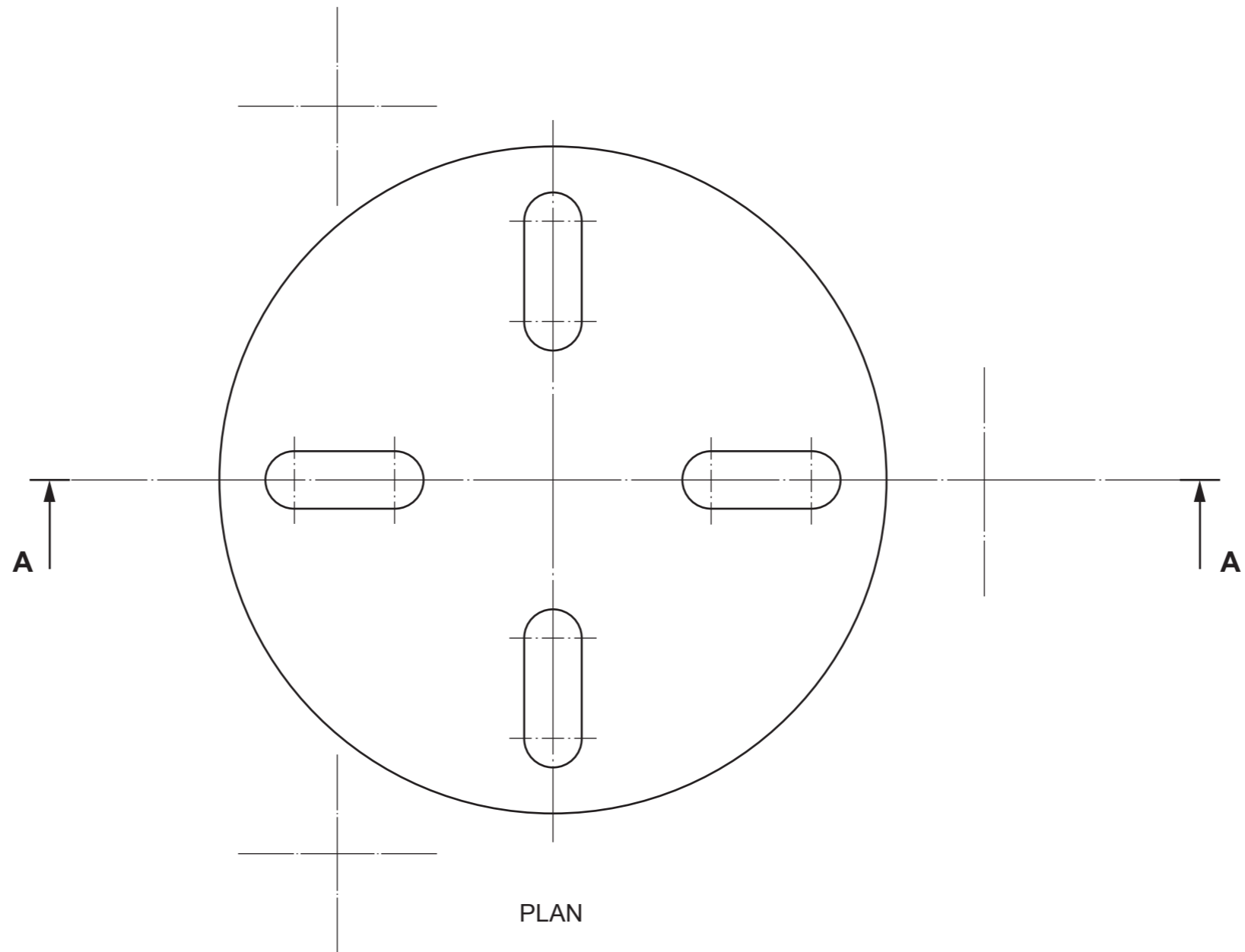

PLAN

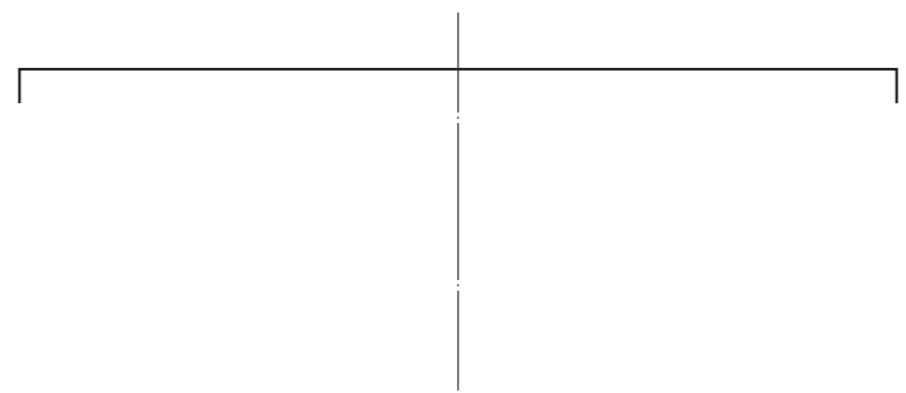

SECTIONAL END ELEVATION A-A

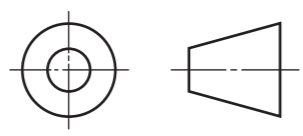

<i>a</i>	
<i>b</i>	
<i>c</i>	
<i>d</i>	
<i>e</i>	
<i>f</i>	
<i>g</i>	
<i>h</i>	
<i>i</i>	
<i>j</i>	
<i>k</i>	
<i>l</i>	
<i>m</i>	
<i>n</i>	

Three orthographic views of a patio and outdoor shower area are given. Draw, full size, the planometric view of the patio and outdoor shower area. Use the corner X as a starting point.

Do not show hidden details.

(20 marks)

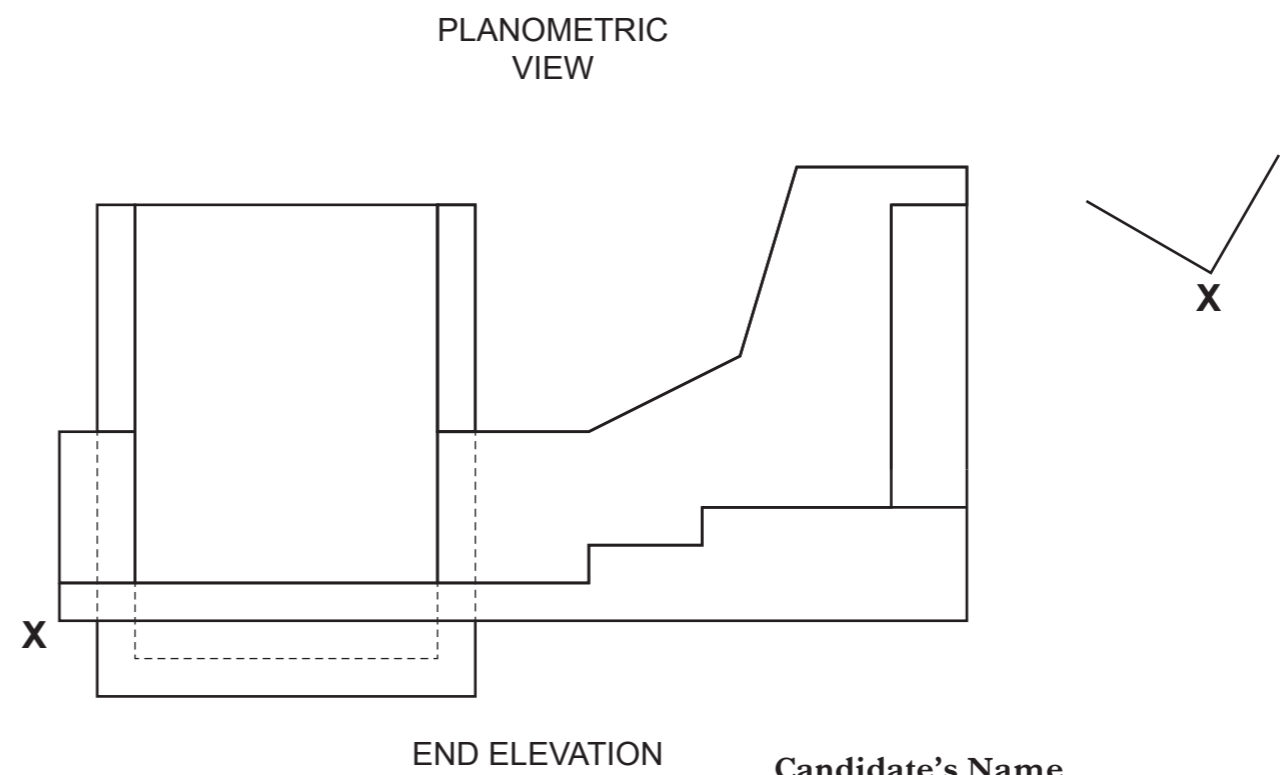
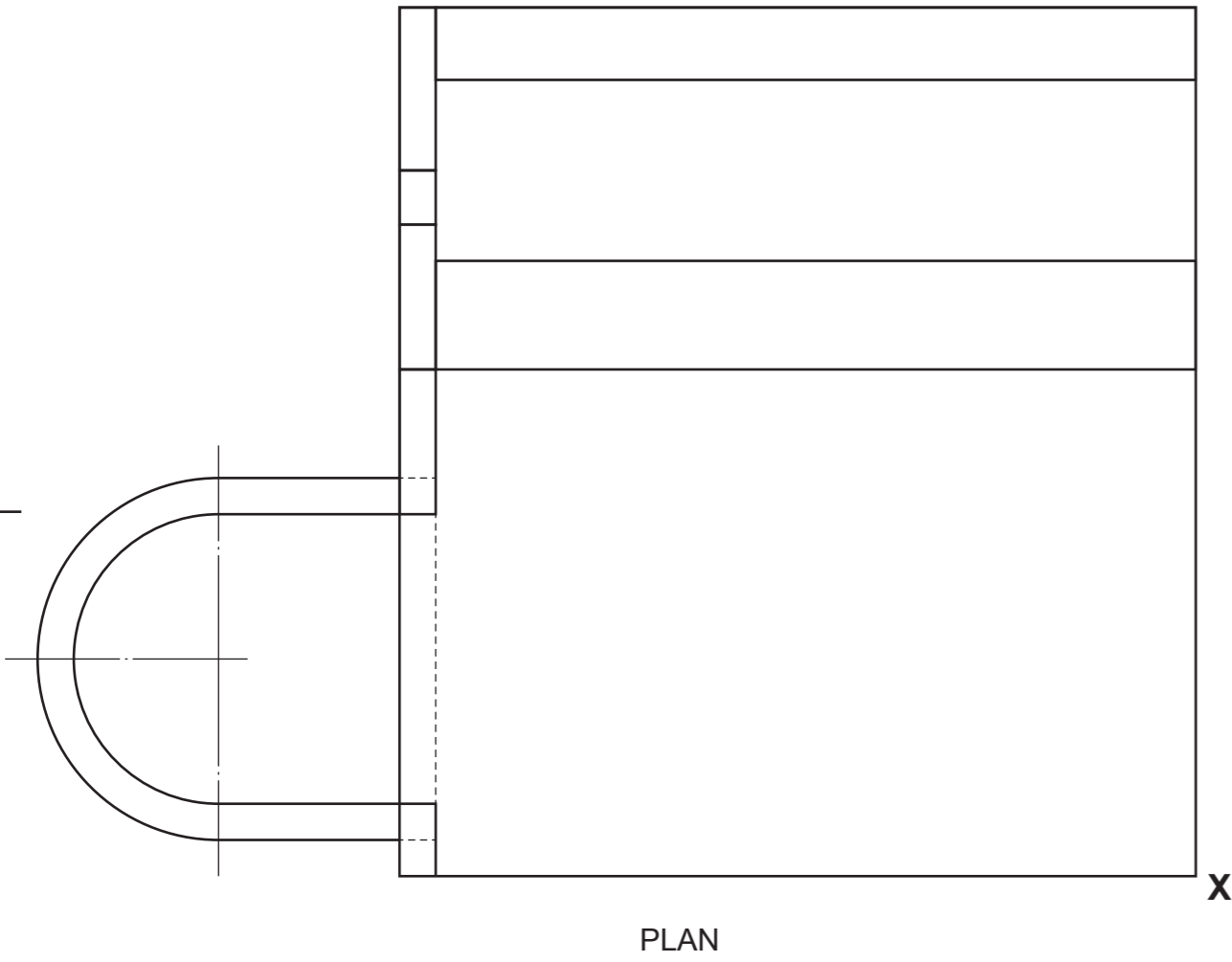

<i>a</i>	
<i>b</i>	
<i>c</i>	
<i>d</i>	
<i>e</i>	
<i>f</i>	
<i>g</i>	
<i>h</i>	
<i>i</i>	
<i>j</i>	
<i>k</i>	
<i>l</i>	
<i>m</i>	
<i>n</i>	

13

Candidates should attempt EITHER Questions 12 OR Question 13

The elevation and end elevation of an information kiosk with a hollow canopy are given.

Draw a 2-point measured perspective view of the kiosk and canopy.

The Spectator Point (SP), Plane of Projection (PP), Ground Line (GL), Eye Level (EL) and plan to the same scale are given.

Do not show hidden details.

(20 marks)

Section B 13

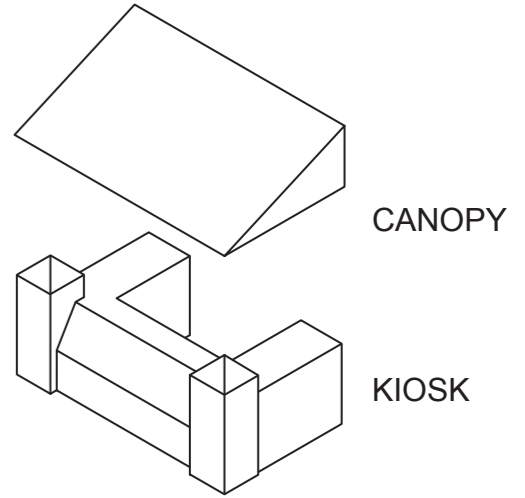

Pictorial view of the kiosk and canopy  
NOT TO SCALE

EL \_\_\_\_\_

GL \_\_\_\_\_

PP \_\_\_\_\_

PP \_\_\_\_\_

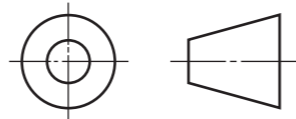
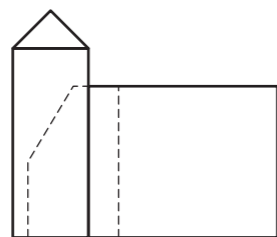
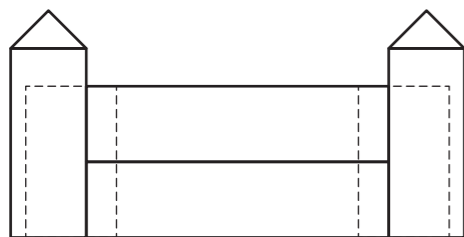
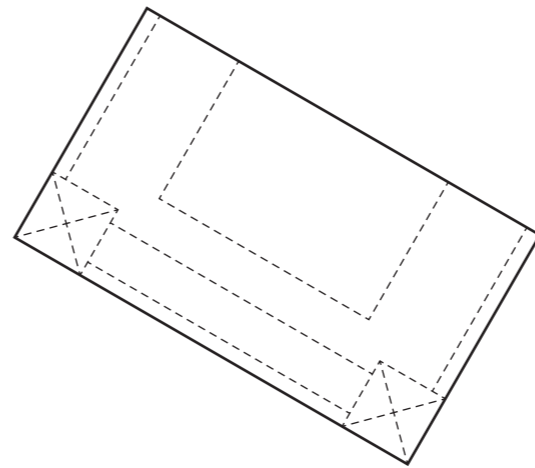
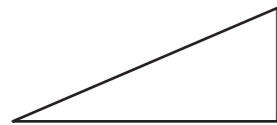

<i>a</i>	
<i>b</i>	
<i>c</i>	
<i>d</i>	
<i>e</i>	
<i>f</i>	
<i>g</i>	
<i>h</i>	
<i>i</i>	
<i>j</i>	
<i>k</i>	
<i>l</i>	
<i>m</i>	
<i>n</i>	

ELEVATION

END ELEVATION

SP

**[BLANK PAGE]**

**DO NOT WRITE ON THIS PAGE**