

STAPLE HERE

FOR OFFICIAL USE

| | | | | | |
|--|--|--|--|--|--|
| | | | | | |
|--|--|--|--|--|--|

X033/1 1/01

NATIONAL
QUALIFICATIONS
2014

THURSDAY, 8 MAY
1.00 PM – 3.30 PM

GRAPHIC
COMMUNICATION
INTERMEDIATE 2

Fill in these boxes and read what is printed below.

Full name of centre

Town

Forename(s)

Surname

Date of birth

Day Month Year

| | | | | | | | |
|--|--|--|--|--|--|--|--|
| | | | | | | | |
|--|--|--|--|--|--|--|--|

Scottish candidate number

| | | | | | | | | | | | | | | |
|--|--|--|--|--|--|--|--|--|--|--|--|--|--|--|
| | | | | | | | | | | | | | | |
|--|--|--|--|--|--|--|--|--|--|--|--|--|--|--|

Number of seat

70 marks are allocated to this paper

- 1 Answer **all** questions.
- 2 Read each question carefully before you answer.
- 3 Written answers may be in **ink** or **pencil**.
- 4 Drawings and sketches **must be in pencil**.
- 5 Dimensions are given in millimetres or as stated.
- 6 Orthographic drawings are in third angle projection.

At the end of the examination

check that your name is on every sheet;
put the sheets in correct numerical order;
place this sheet on top of the others;
join all sheets together by **stapling** at the top left-hand corner;
before leaving the examination room, you must give these sheets to the Invigilator
(if you do not you may lose all the marks for this paper).

| Question | Marks |
|-------------|-------|
| 1 | |
| 2 | |
| 3 | |
| 4 | |
| 5 | |
| 6 | |
| 7 | |
| 8 | |
| Total Marks | |



The new sun loungers for a holiday resort are to be blue.

(a) State the effect this colour would have on the pool area.

..... (1)

(b) State a tertiary colour for the parasols that harmonises with the blue sun loungers.

..... (1)

(c) State a contrasting colour to the blue sun loungers for the sun lounge towels.

..... (1)

(d) A tint of blue was chosen for the tiles in the swimming pool. State what is added to blue to create a tint of blue.

..... (1)

(4 marks)



Various stages in the production of a holiday company's new logo are shown below.

(a) State the **single** Illustration and Presentation command used at each stage, in the positions indicated:

Before

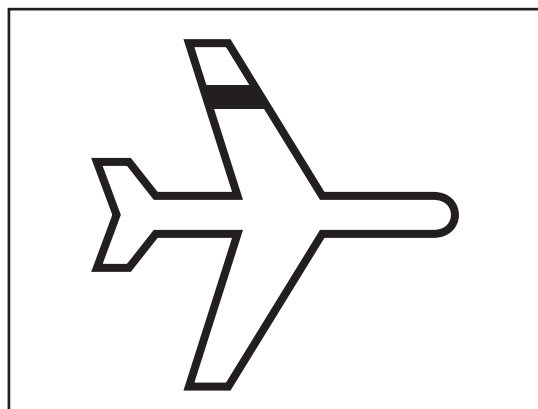

After

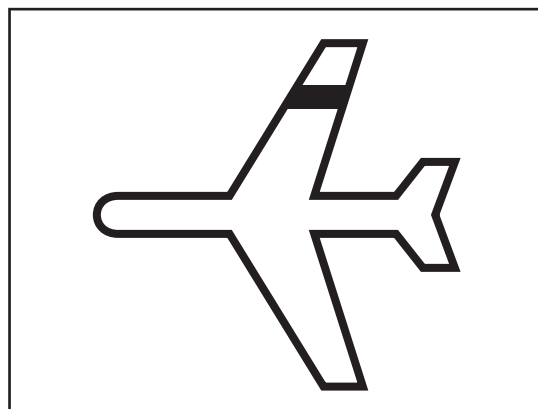

Command (1)

Before

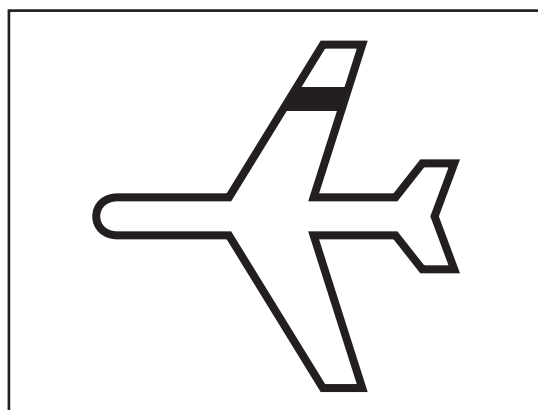

After



Command (1)

Before



After

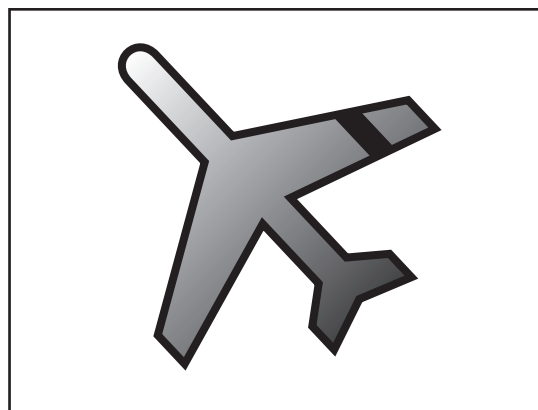

Command (1)



(b) State **two** advantages of using CAG, compared with manual production methods, to produce the holiday company's logo shown above.

Advantage 1: (1)

Advantage 2: (1)

(5 marks)

A CAD floor plan for an airport security office is shown opposite.

The potential layout of various input, output and storage devices used in the office have also been included in the plan.

(a) From the plan opposite:

- (i) state an input device; (1)
- (ii) state a storage device; (1)
- (iii) state an output device. (1)

(b) State the name of the BSI symbol shown at

A (1)

B (1)

C (1)

(6 marks)

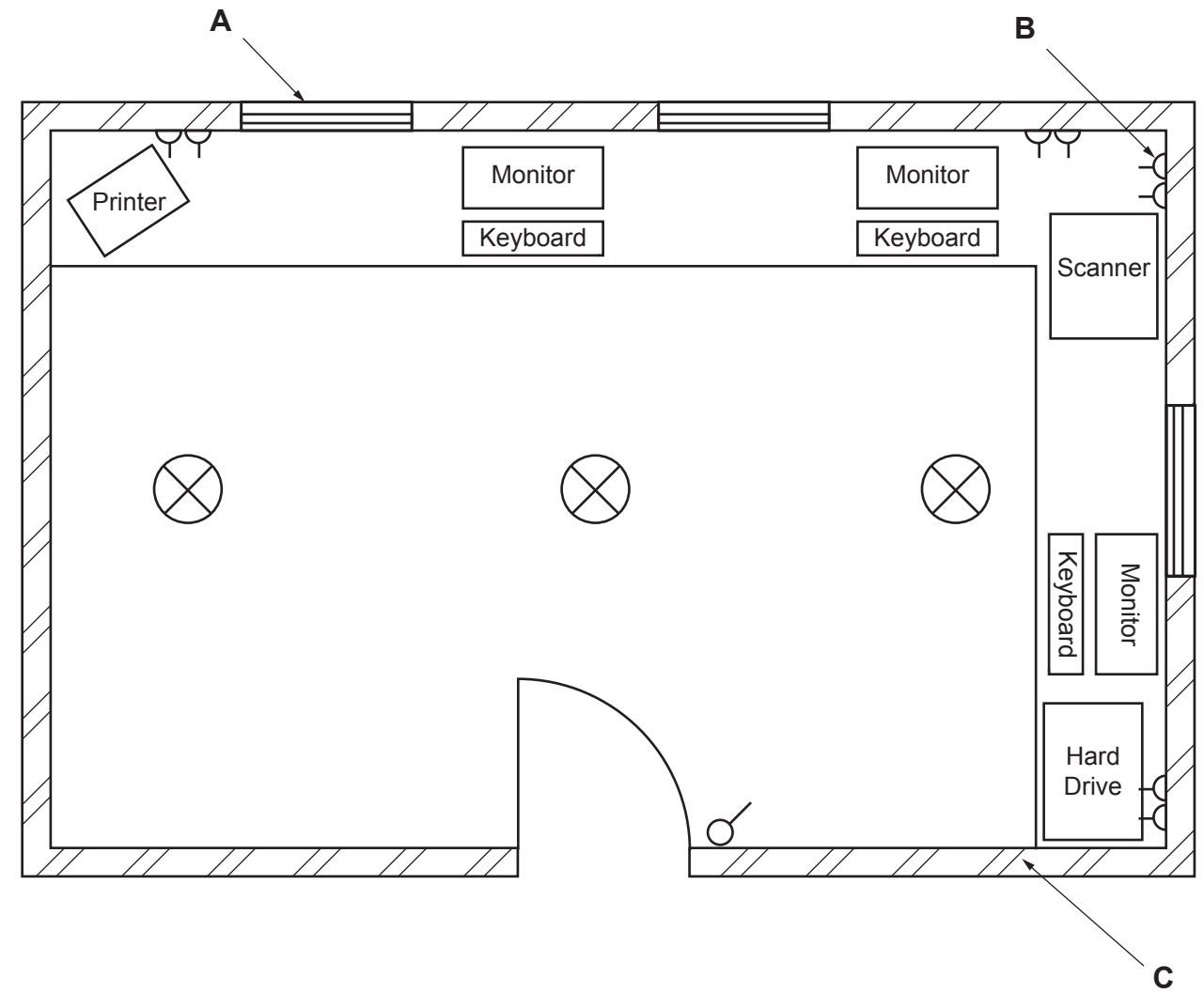

Various views of a child's toy bucket are given.

(a) State the name of the type of drawing shown in **View A**.

..... (1)

(b) State the purpose of the drawing shown in **View A**.

..... (1)

(c) State the correct angle of the hatch lines shown in **View A** according to British Standards.

..... (1)

(d) State why the hatch lines in **View A** are drawn in different directions.

..... (1)

(e) State the name of the type of drawing shown in **View B**.

..... (1)

(5 marks)

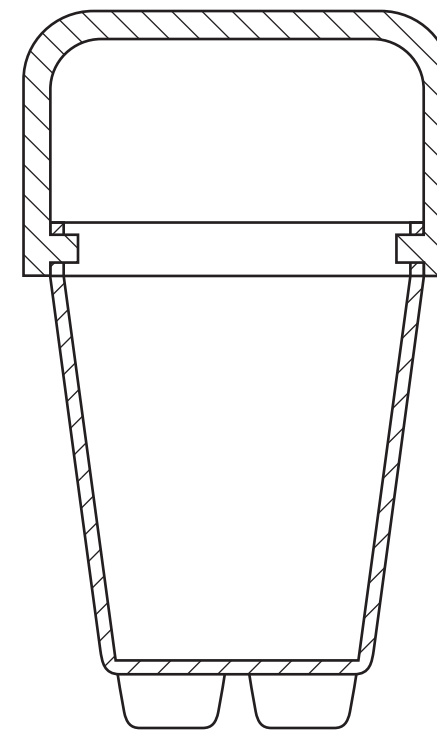

View A

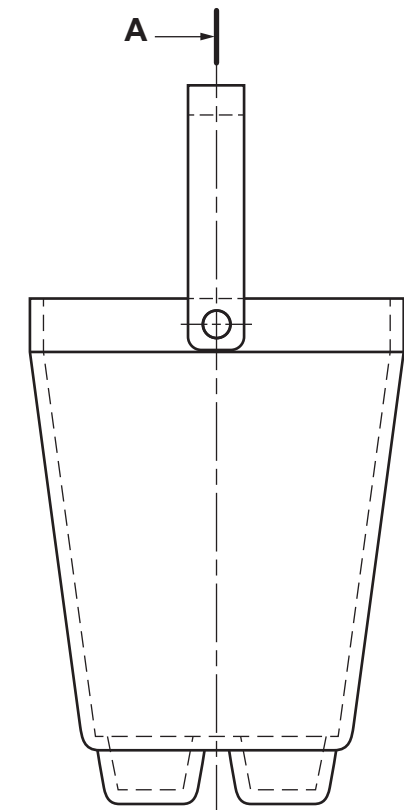

End Elevation

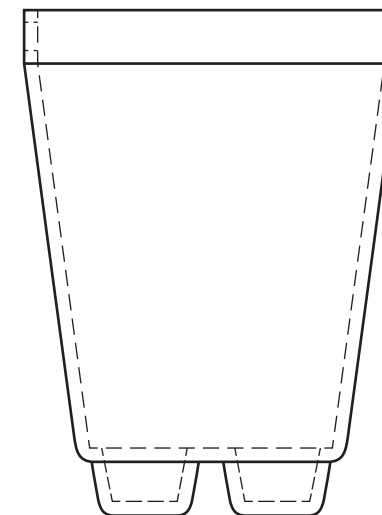
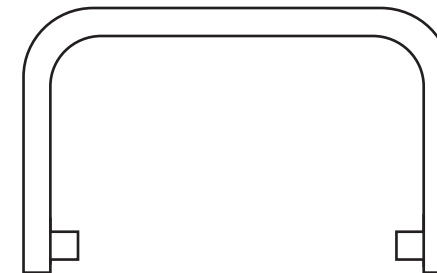

View B

5

The elevation and incomplete plan of a child's spade are given. A pictorial view is shown.

Draw, full size, in the position indicated:

- (a) the completed plan;
- (b) the end elevation.

Show all hidden detail.

(8 marks)

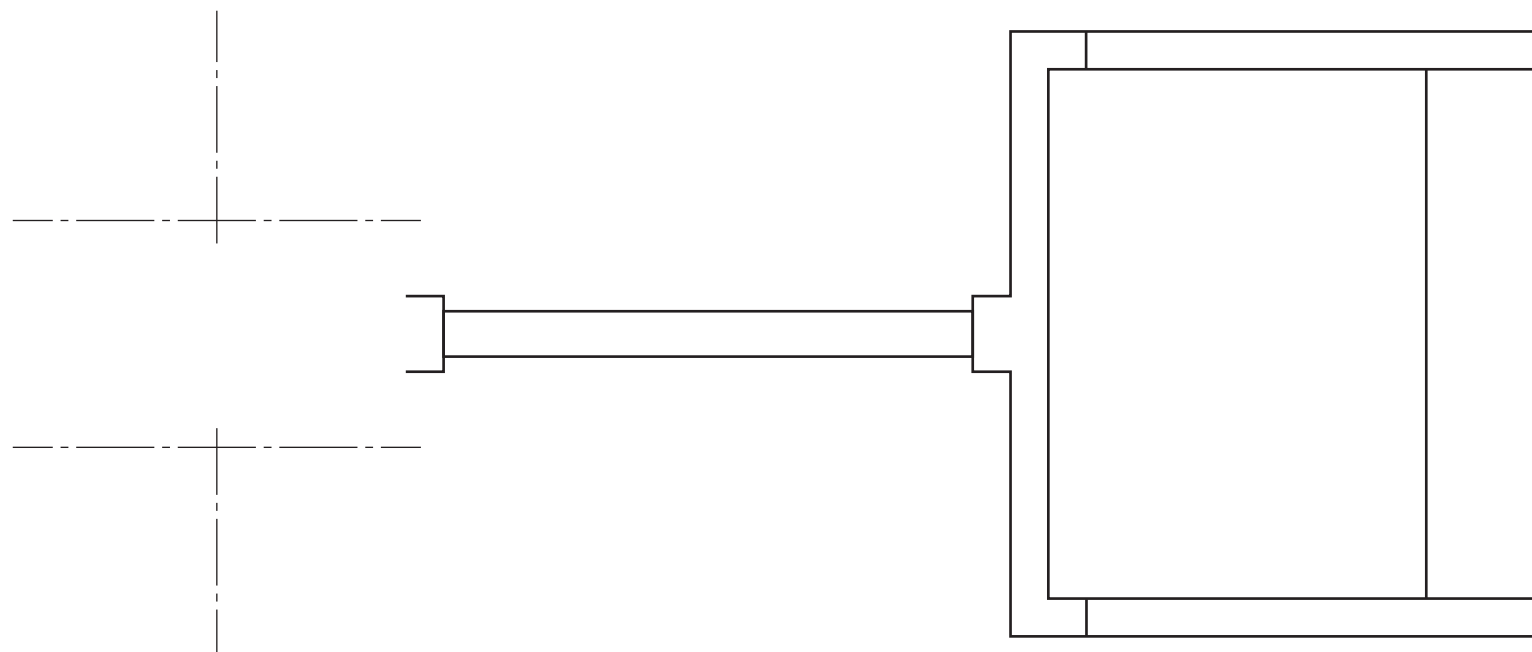

Plan

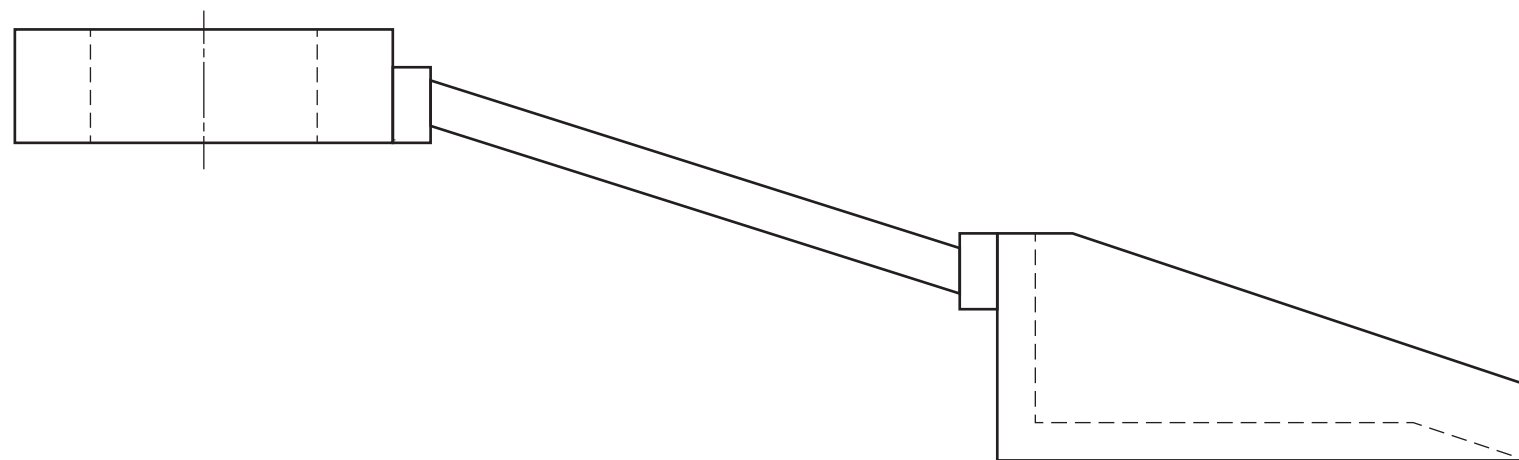

Elevation

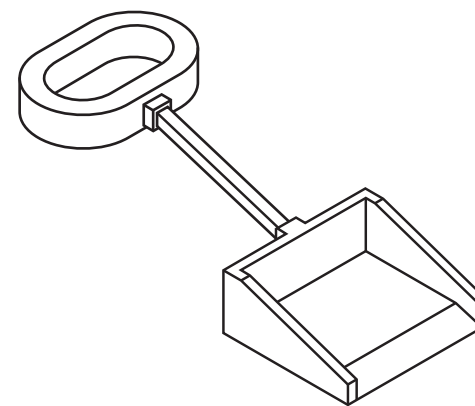

Pictorial View

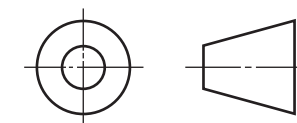

5

| | |
|----------|--|
| <i>a</i> | |
| <i>b</i> | |
| <i>c</i> | |
| <i>d</i> | |
| <i>e</i> | |
| <i>f</i> | |
| <i>g</i> | |
| <i>h</i> | |
| <i>i</i> | |
| <i>j</i> | |
| <i>k</i> | |
| <i>l</i> | |
| <i>m</i> | |
| <i>n</i> | |
| | |



End Elevation

6

The plan and elevation of the corner of an airport departure lounge are given.

Draw a planometric view of the departure lounge, in the position given, using starting point X.

Do not draw text on signs.

Do not show hidden detail.

(14 marks)

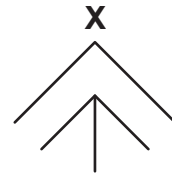

6

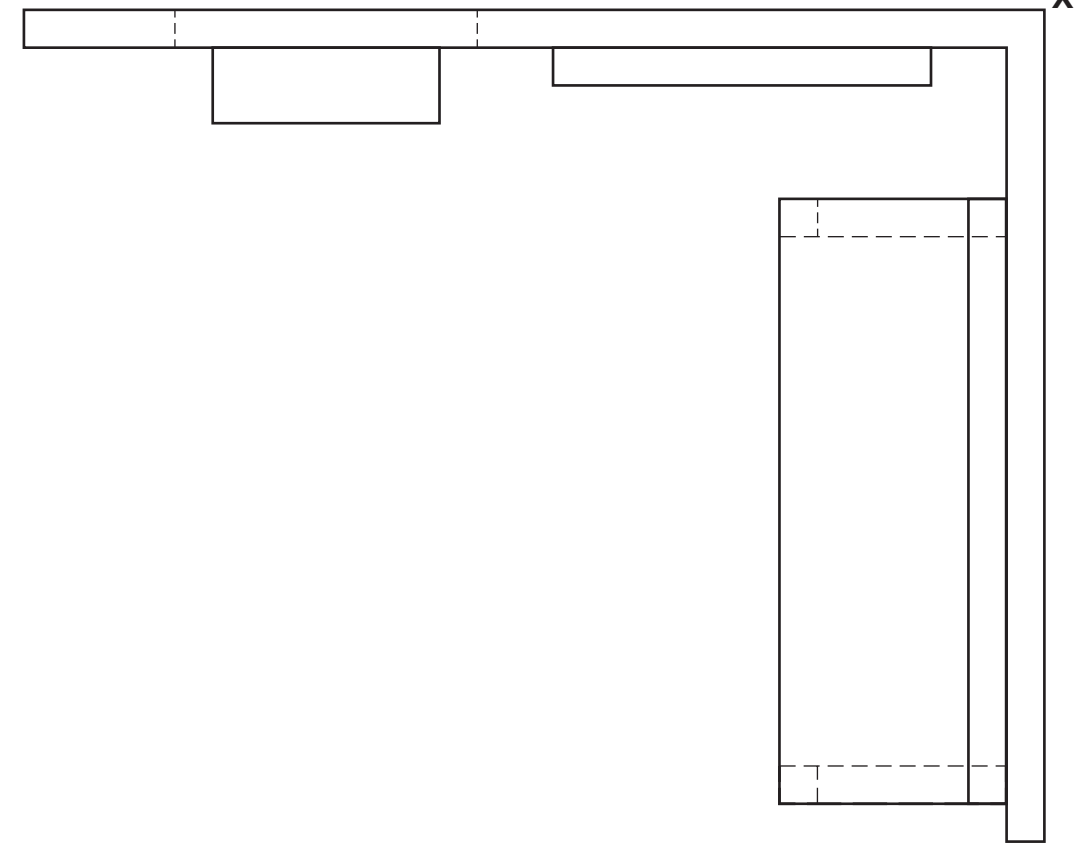

Plan

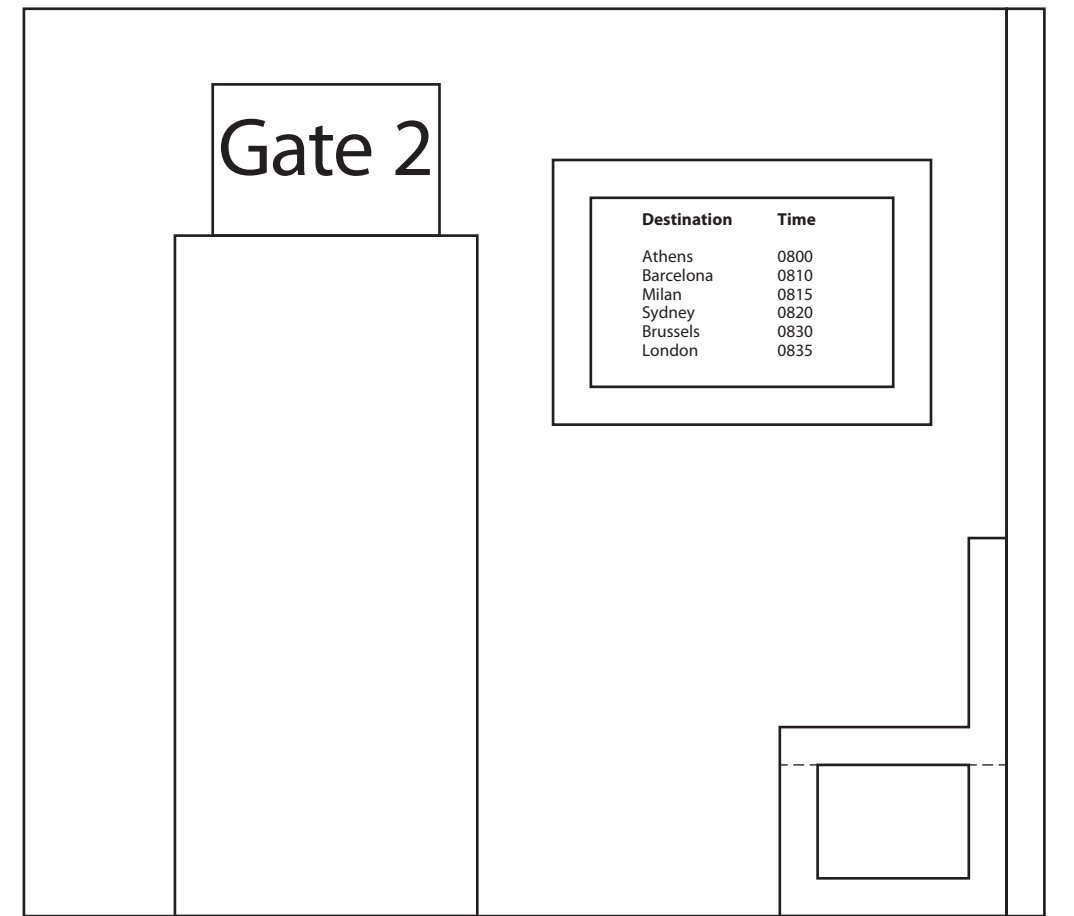

Elevation

| | |
|----------|--|
| <i>a</i> | |
| <i>b</i> | |
| <i>c</i> | |
| <i>d</i> | |
| <i>e</i> | |
| <i>f</i> | |
| <i>g</i> | |
| <i>h</i> | |
| <i>i</i> | |
| <i>j</i> | |
| <i>k</i> | |
| <i>l</i> | |
| <i>m</i> | |
| <i>n</i> | |
| | |

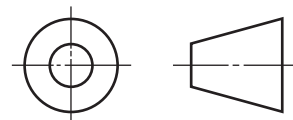

Candidate's Name _____

7

The elevation and plan of a sun lotion bottle are given.

A pictorial view is also shown.

Draw, full size, in the positions indicated:

- (a) the end elevation;
- (b) the true shape of surface **A**;
- (c) the surface development of the sides of the lid.

Show all hidden detail.

(14 marks)

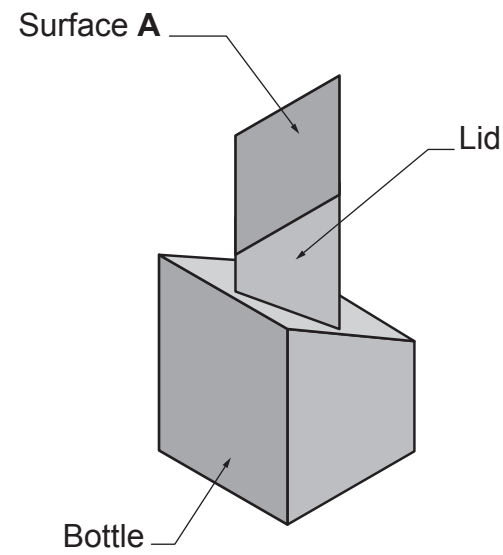

Pictorial View

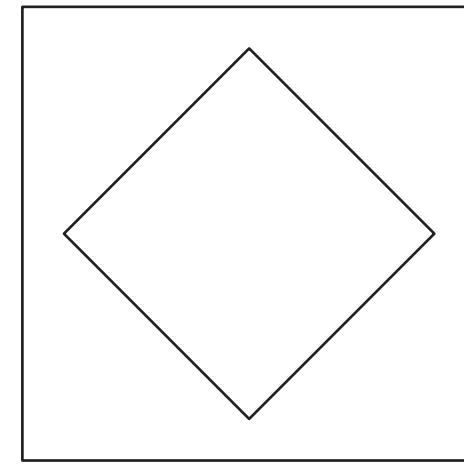

Plan

7

Development of Lid



End Elevation

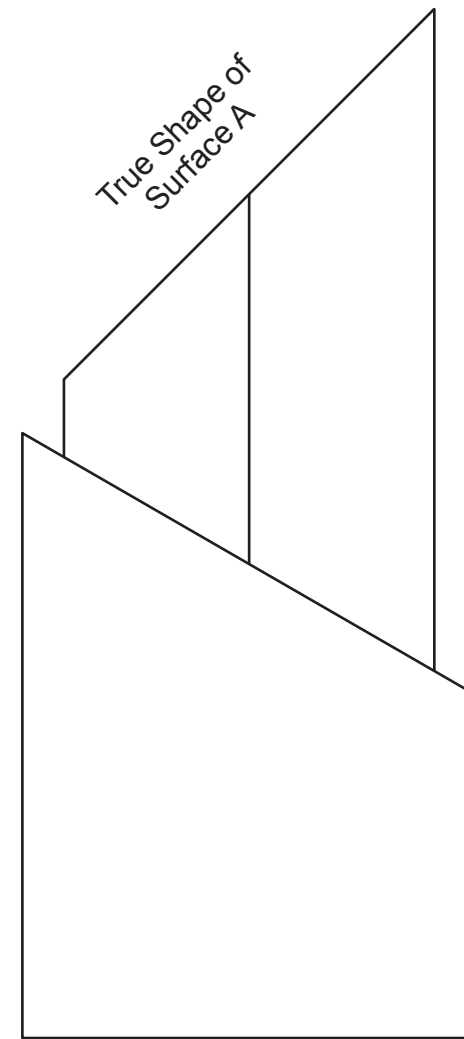

Elevation

| | |
|----------|--|
| <i>a</i> | |
| <i>b</i> | |
| <i>c</i> | |
| <i>d</i> | |
| <i>e</i> | |
| <i>f</i> | |
| <i>g</i> | |
| <i>h</i> | |
| <i>i</i> | |
| <i>j</i> | |
| <i>k</i> | |
| <i>l</i> | |
| <i>m</i> | |
| <i>n</i> | |
| | |

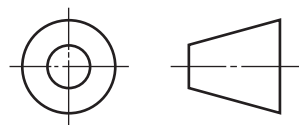

8

Orthographic views of three component parts of a cool box are given.

An assembled pictorial view is also shown.

Draw, in the position indicated, the sectional elevation on **A-A** of the assembled cool box.

Do not show hidden detail.

(14 marks)

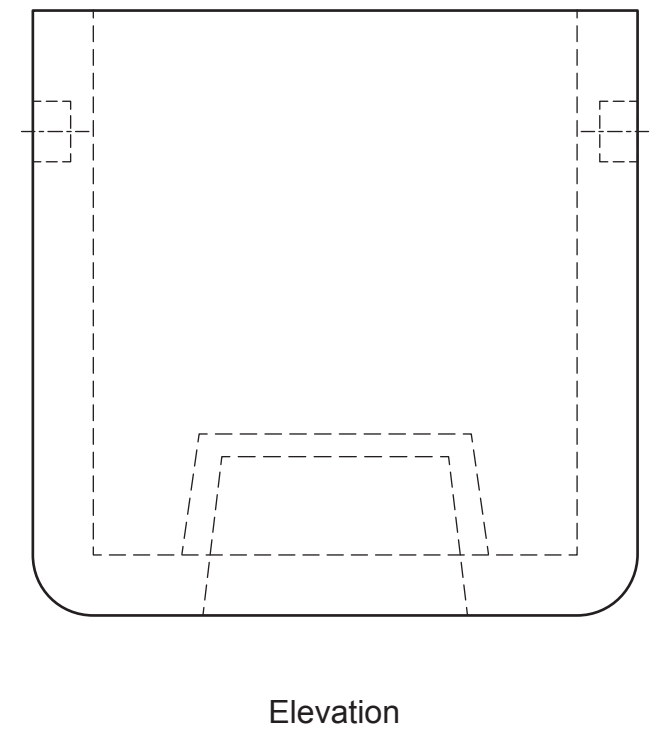
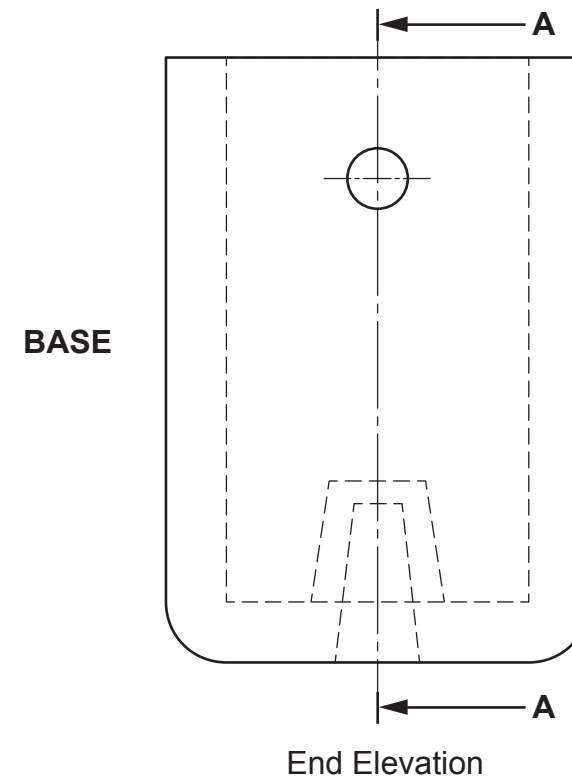
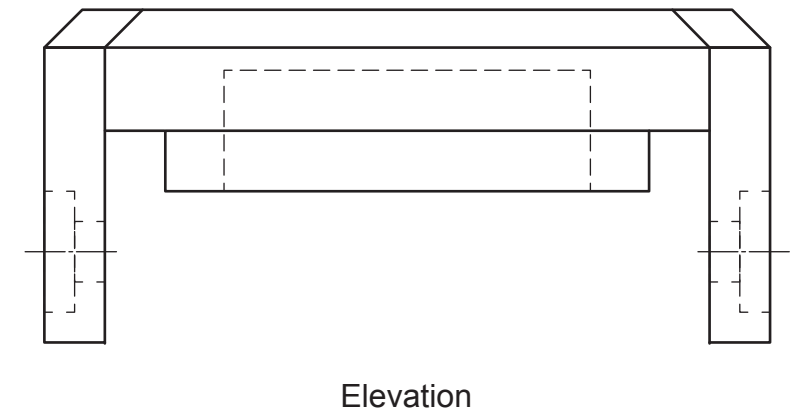
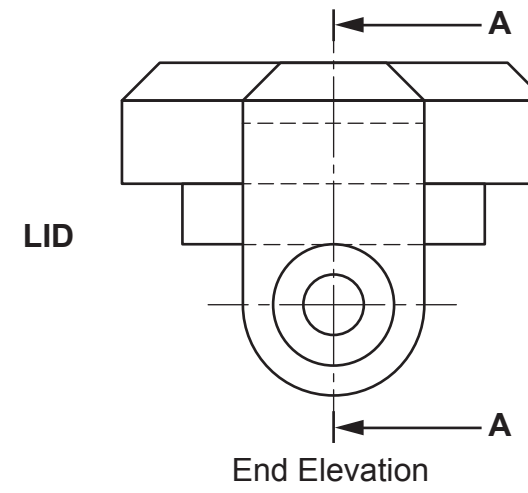
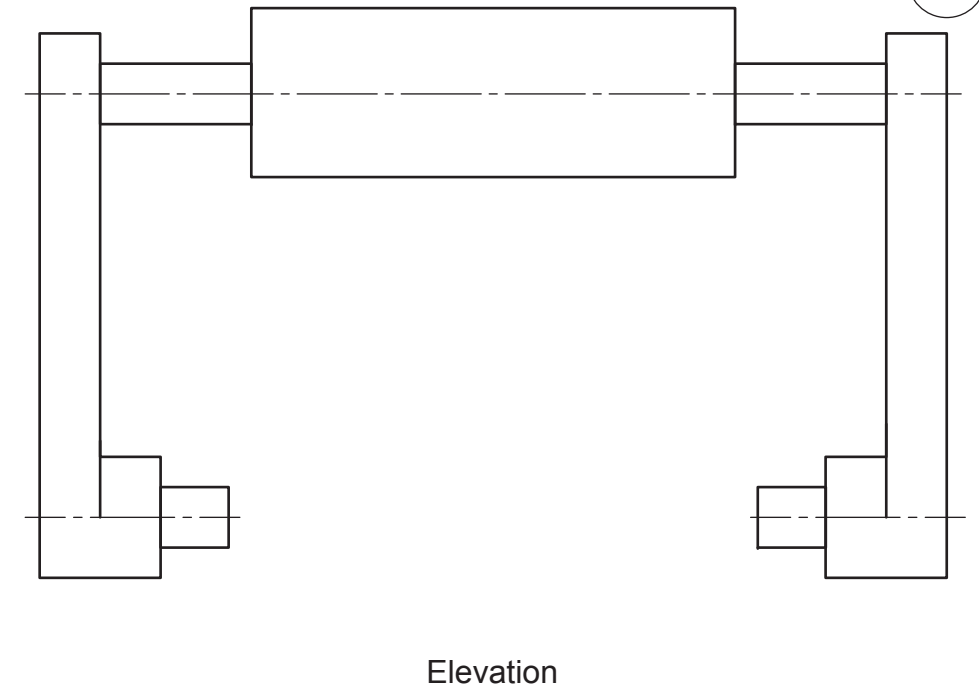
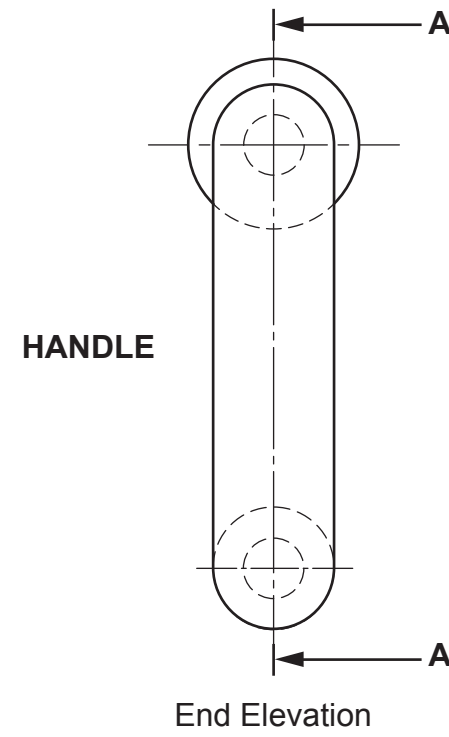
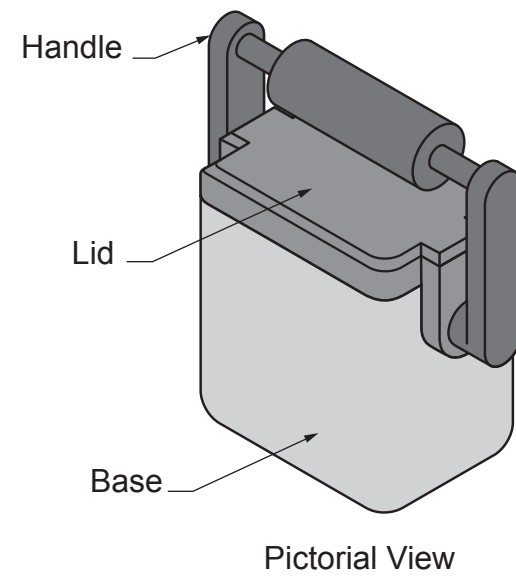

| | |
|----------|--|
| <i>a</i> | |
| <i>b</i> | |
| <i>c</i> | |
| <i>d</i> | |
| <i>e</i> | |
| <i>f</i> | |
| <i>g</i> | |
| <i>h</i> | |
| <i>i</i> | |
| <i>j</i> | |
| <i>k</i> | |
| <i>l</i> | |
| <i>m</i> | |
| <i>n</i> | |
| | |

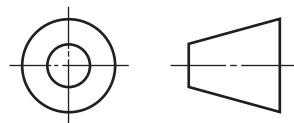

Sectional Elevation on **A-A**

8

ACKNOWLEDGEMENT

Question 1 – 37021675 Shutterstock.com