

FOR OFFICIAL USE



National
Qualifications
2016

Mark

X723/77/01

Engineering Science

WEDNESDAY, 11 MAY

9:00 AM – 11:00 AM



* X 7 2 3 7 7 0 1 *

Fill in these boxes and read what is printed below.

Full name of centre

Town

Forename(s)

Surname

Number of seat

Date of birth

Day

Month

Year

Scottish candidate number

Total marks — 60

Reference may be made to the **Advanced Higher Engineering Science Data Booklet**.

SECTION 1 — 30 marks

Attempt ALL questions

SECTION 2 — 30 marks

Attempt ALL questions

Write your answers clearly in the spaces provided in this booklet. Additional space for answers is provided at the end of this booklet. If you use this space you must clearly identify the question number you are attempting.

Show all working and units where appropriate.

The number of significant figures expressed in a final answer should be equivalent to the least significant data value given in the question. Answers that have two more figures or one less figure than this will be accepted.

Use **blue** or **black** ink.

Before leaving the examination room you must give this booklet to the Invigilator; if you do not, you may lose all the marks for this paper.



* X 7 2 3 7 7 0 1 0 1 *

SECTION 1 — 30 marks

Attempt ALL questions

1. A project manager used Critical Path Analysis to help manage a 7-stage project.

A node for the activity network used is shown below.

EST = earliest possible start time
 LST = latest possible start time
 EFT = earliest possible finish time
 LFT = latest possible finish time
 F = float

EST	activity	EFT
		F
LST	duration	LFT

A partially completed version of the activity network is given below.

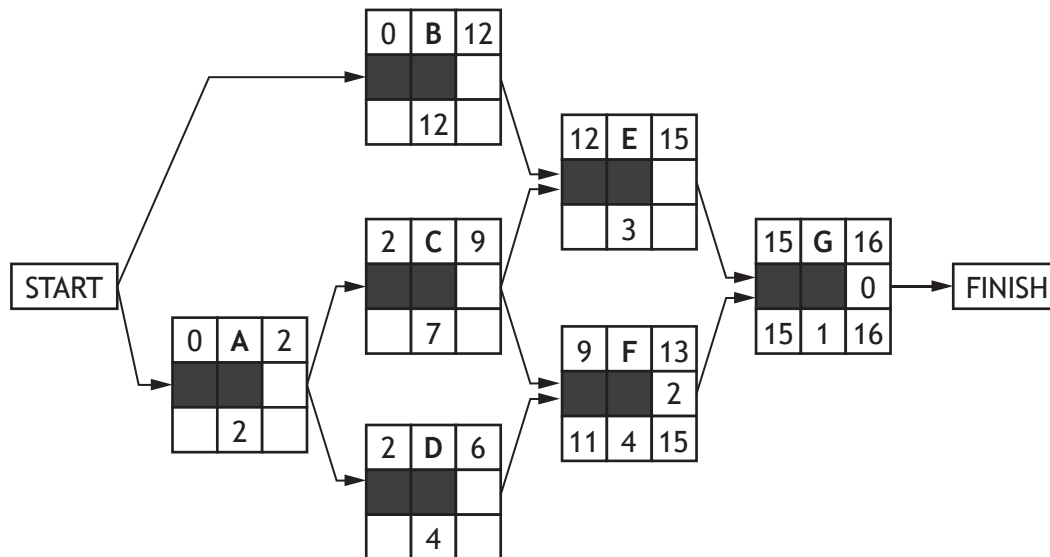

- (a) Complete the activity network above by adding the latest finish time, the earliest finish time and the float for each of activities A–E, and hence identify the critical path.

3

Critical Path _____



1. (continued)

(b) Describe **two** steps that the project manager might take to ensure that the activities on the critical path in this project are not delayed.

2

[Turn over



2. A structural engineer produces a non-standard cross-sectional component using 3D printing technology and using ABS polycarbonate plastic. The square section has outside dimension 50 mm, as shown below. All walls are 10 mm thick.

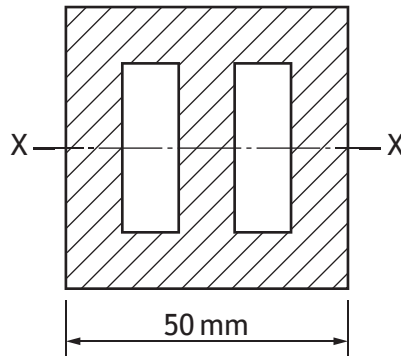

- (a) Calculate the second moment of area about the axis X–X of the section shown above.

3

A cantilever beam of length 500 mm is produced from this material and a vertical load of 75 N is applied at the free end.

- (b) Calculate the deflection of the free end of the beam.

2



* X 7 2 3 7 7 0 1 0 4 *

3. A diagram of a simple electricity supply system is shown below.

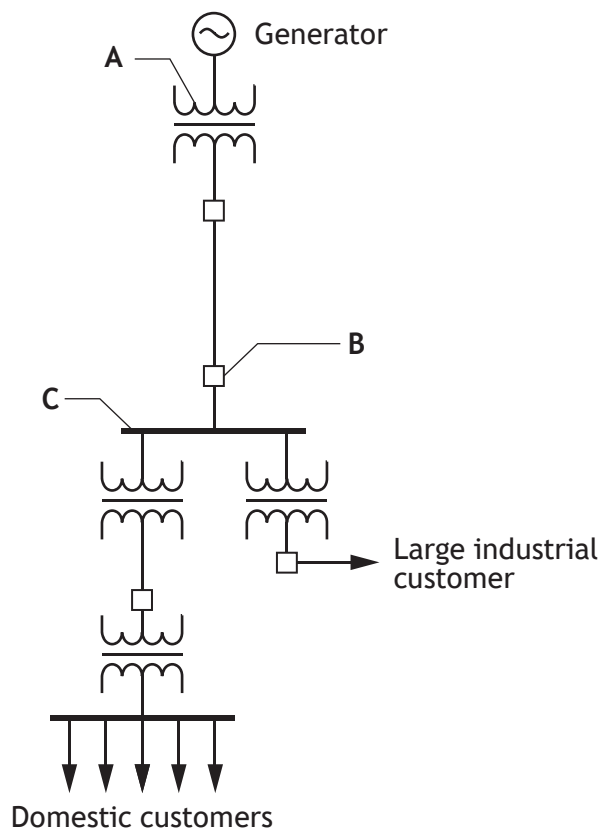

(a) Describe the function of each of the labelled transmission sub-systems. 3

A Transformer _____

B Circuit Breaker _____

C Bus Bar _____

[Turn over



3. (continued)

A single-phase line feeds a rural property. The cable is 100 m long and has a resistance of 0.727 ohms per kilometre. The resistive power consumption at the property is 14 kW. The single-phase voltage is 230 V.

(b) Calculate the efficiency of the line.

2



[Turn over for next question

DO NOT WRITE ON THIS PAGE



* X 7 2 3 7 7 0 1 0 7 *

4. A pupil simulated the circuit shown below.

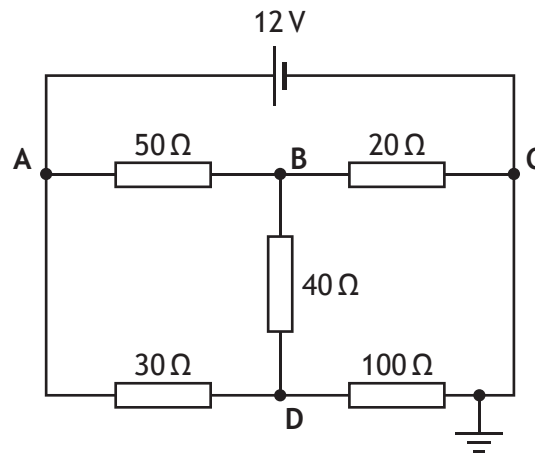

Calculate, using nodal analysis, the voltages at nodes B and D.

5



4. (continued)

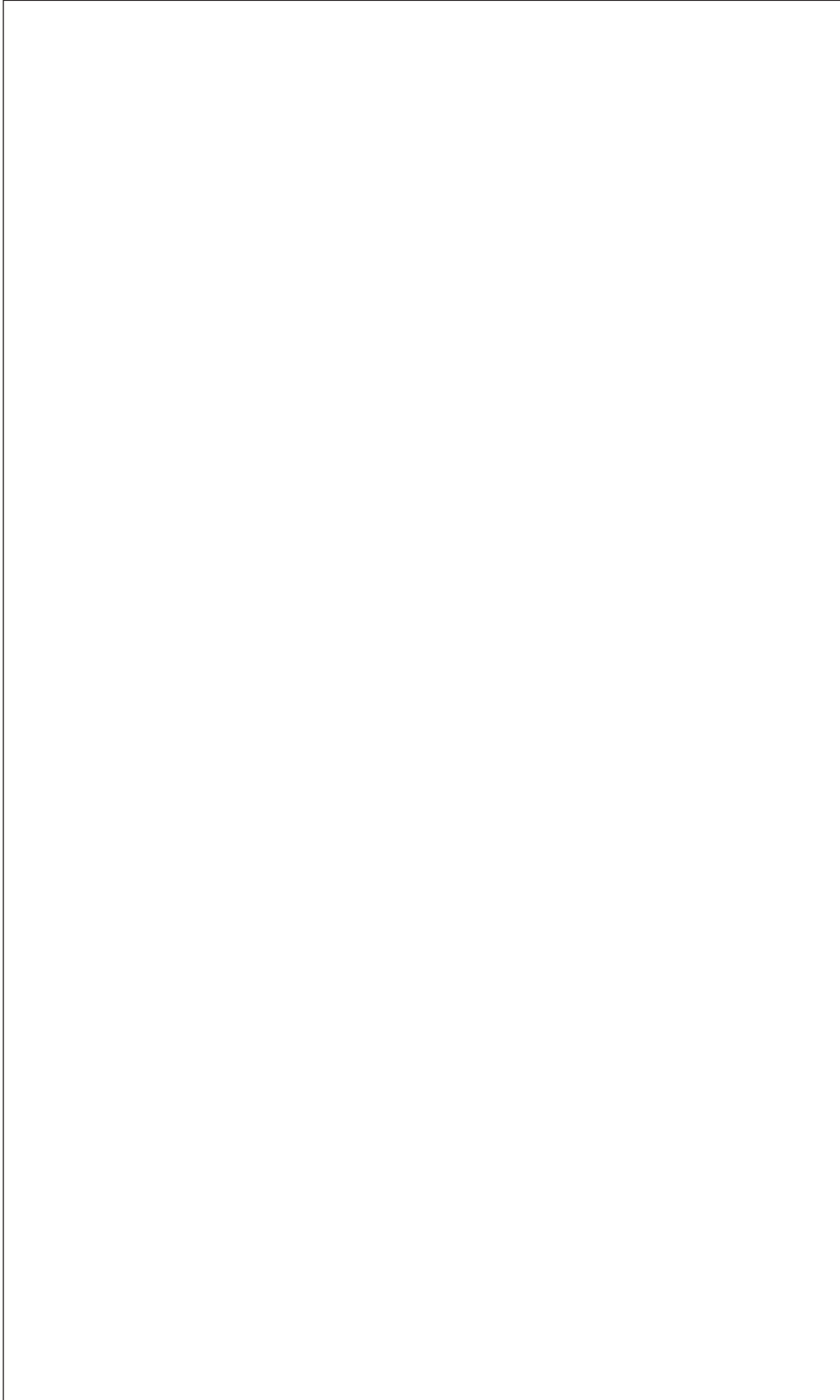

5. A microcontroller is used to control the speed of a motor using Pulse Width Modulation (PWM). The microcontroller signal is amplified by an n-channel enhancement MOSFET driver.

The circuit diagram and graphs below show the setup for controlling the motor.

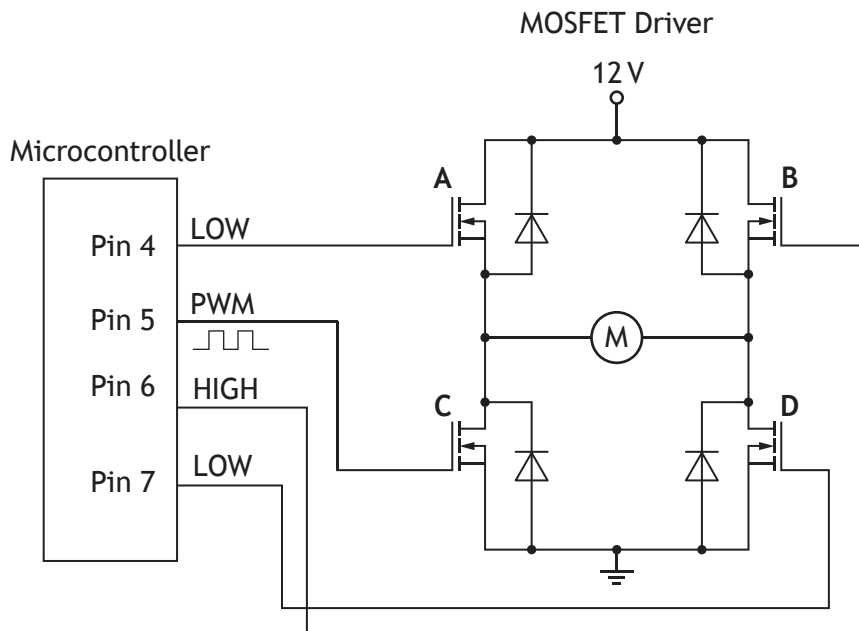

Graph 1 below shows the input PWM signal to MOSFET C from Pin5 of the Microcontroller.

Graph 1

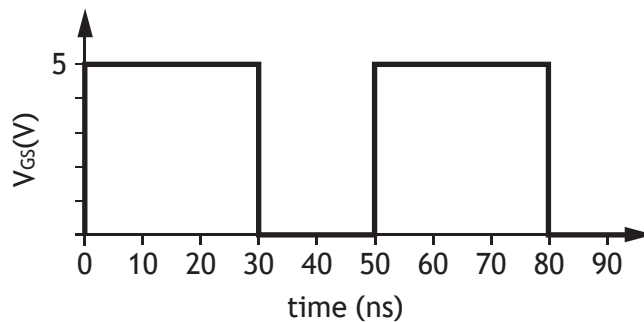

* X 7 2 3 7 7 0 1 1 0 *

5. (continued)

Graph 2 below shows the current I_{DS} which passes through MOSFET C.

Graph 2

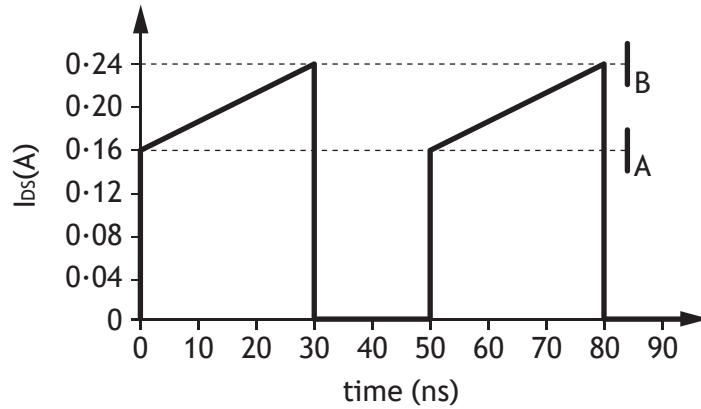

$R_{DS(on)}$ for MOSFET C is 0.2Ω .

$I_{DS(on)}$ for MOSFET C can be calculated using the formula below.

D, the Duty Cycle, is the ratio of the mark to the period in each graph.

$$I_{DS(on)} = D \sqrt{\frac{I_B^2 + (I_A \times I_B) + I_A^2}{3}}$$

(a) Calculate the conduction power loss in MOSFET C.

3



* X 7 2 3 7 7 0 1 1 1 *

5. (continued)

To run the motor clockwise MOSFETs A and D switch on together.

To run the motor anticlockwise MOSFETs B and C switch on together.

When changing the direction of the motor, there is the potential for all four MOSFETs in the driver to be switched on at the same time.

(b) Explain why this should be avoided and how it can be prevented.

2



* X 7 2 3 7 7 0 1 1 2 *

[Turn over for next question

DO NOT WRITE ON THIS PAGE



* X 7 2 3 7 7 0 1 1 3 *

6. In the diesel engine of a truck, the alternator is positioned so that it is driven by the engine crankshaft, via a tensioned belt and pulley. The input torque at the alternator pulley is balanced by a torque in the windings of the alternator.

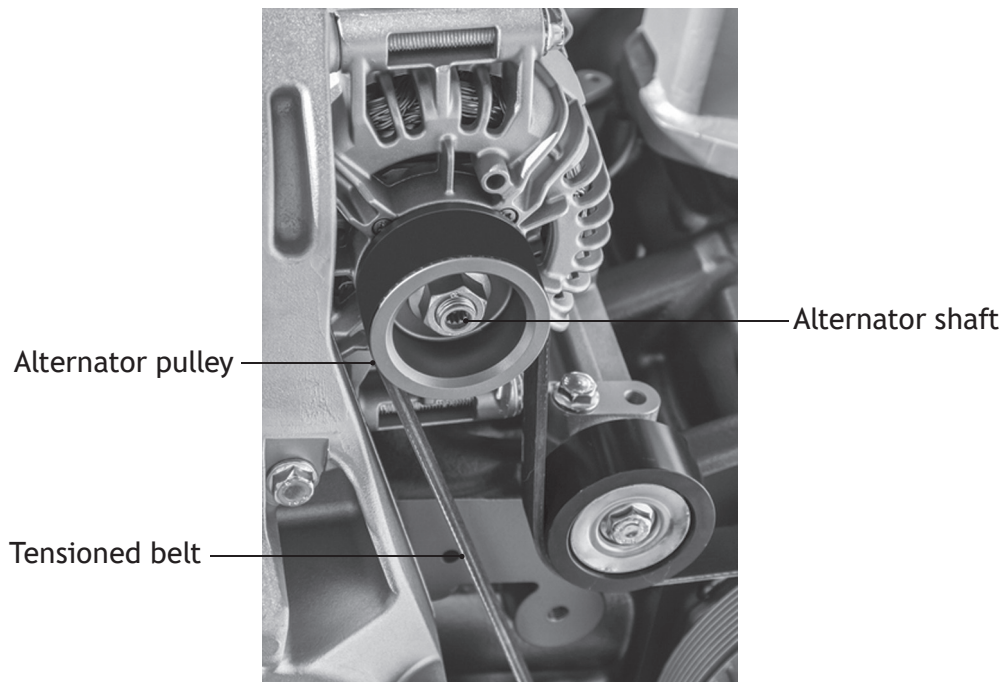

The shaft of the alternator is supported on two bearings at points A and B, as shown below. It supports the alternator pulley outside bearing A and a load of 100 N between the bearings.

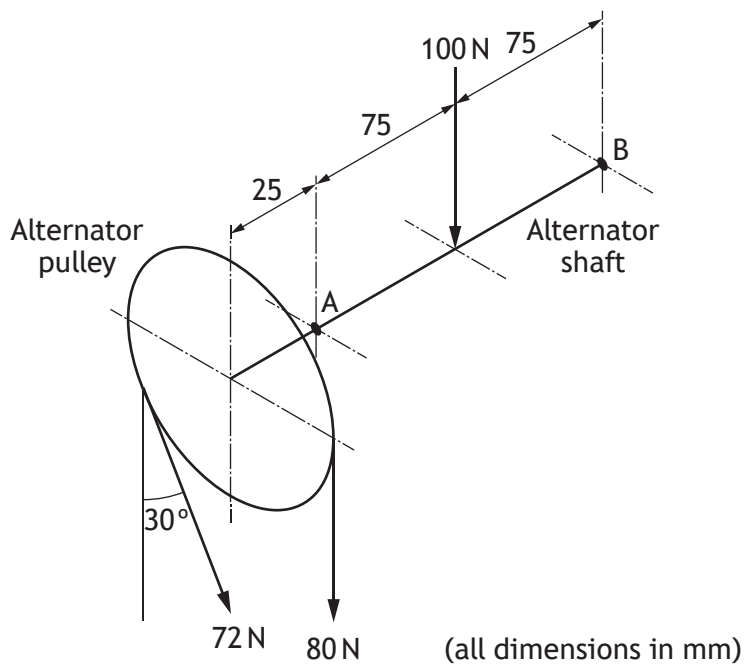

* X 7 2 3 7 7 0 1 1 4 *

6. (continued)

Calculate, for the loads specified, the magnitude and direction of the reaction at bearing A.

5

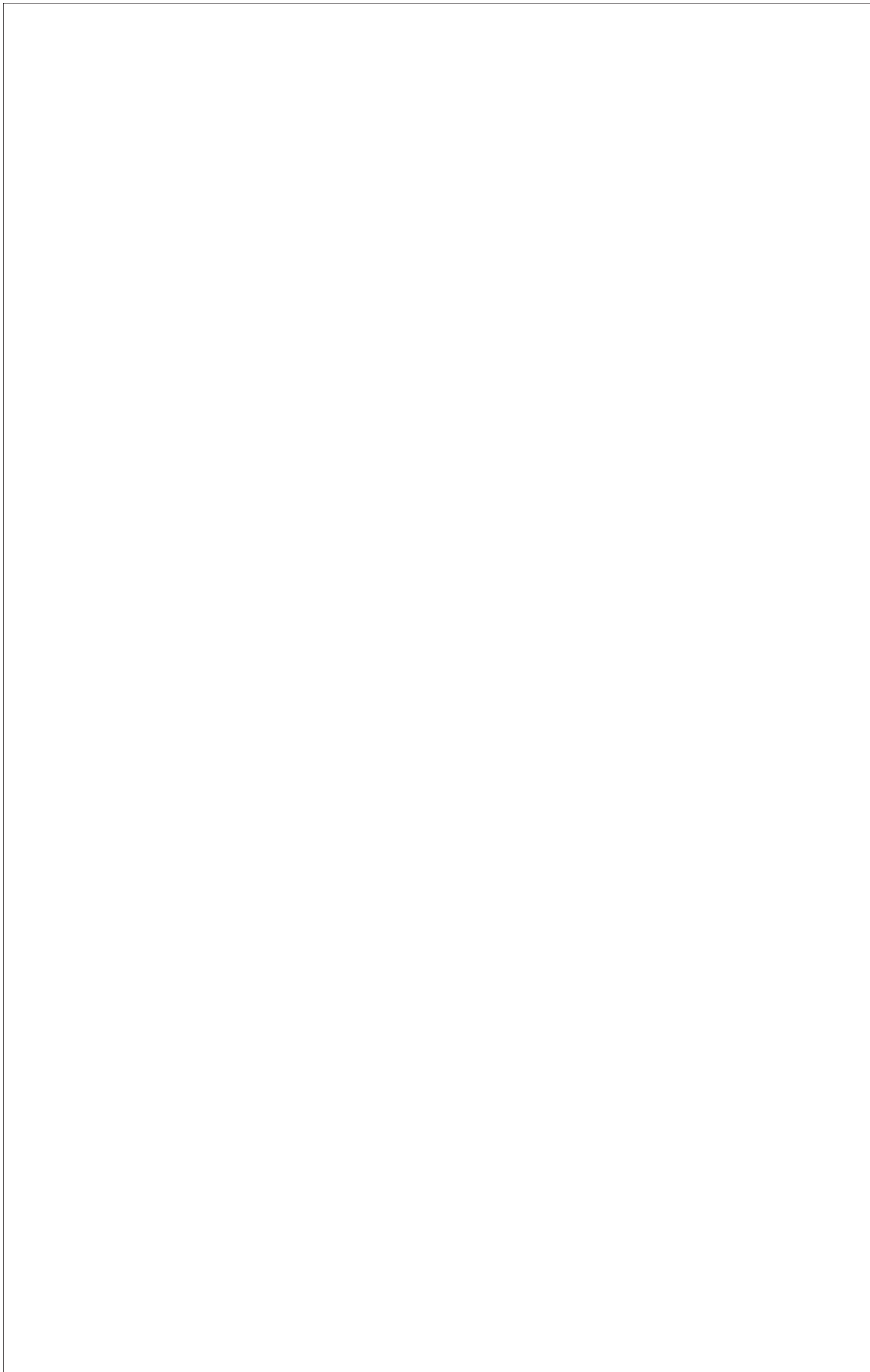

* X 7 2 3 7 7 0 1 1 5 *

SECTION 2 — 30 marks

Attempt ALL questions

DO NOT
WRITE IN
THIS
MARGIN

7. A camera drone is being designed by an engineer for the consumer market.



A three-axis accelerometer is used to measure the acceleration of the drone whilst in flight. For each axis of movement, the accelerometer produces a voltage which is proportional to the acceleration of the drone on a particular axis.

For one axis of movement, a voltage, V_A , is processed by the following two-stage integrator circuit. The operational amplifiers (op-amps) saturate at $\pm 13.5\text{ V}$.

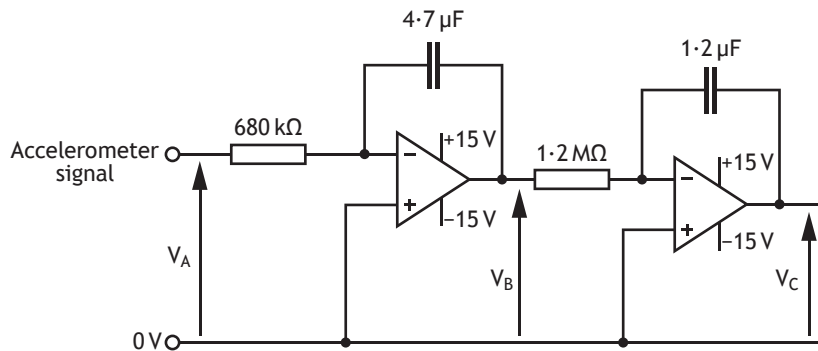

The first integrator integrates the input voltage V_A with respect to time. This produces a voltage signal V_B which represents the velocity of the drone on a particular axis. The second integrator integrates the voltage V_B with respect to time to produce a voltage V_C which represents the distance travelled on a particular axis.

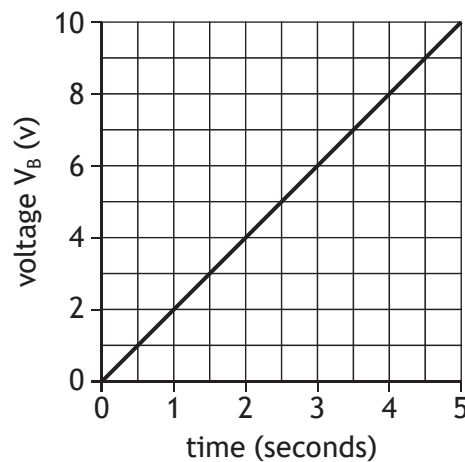

7. (continued)

- (a) (i) Write, referring to the graph opposite, the equation for V_B in terms of time.

1

- (ii) Write, referring to the circuit diagram opposite, the equation for V_C in its simplest form, substituting all known values.

2

- (iii) Sketch the graph of V_C with respect to time. Include significant values and label the axes. Assume that $V_C = 0V$ when $t = 0s$.

3



MARKS

DO NOT
WRITE IN
THIS
MARGIN

7. (a) (continued)

(iv) Calculate the value of V_A .

2



* X 7 2 3 7 7 0 1 1 8 *

7. (continued)

Sales of the camera drone change over time. The graph below shows the four stages, indicated by A–D, of the product cycle.

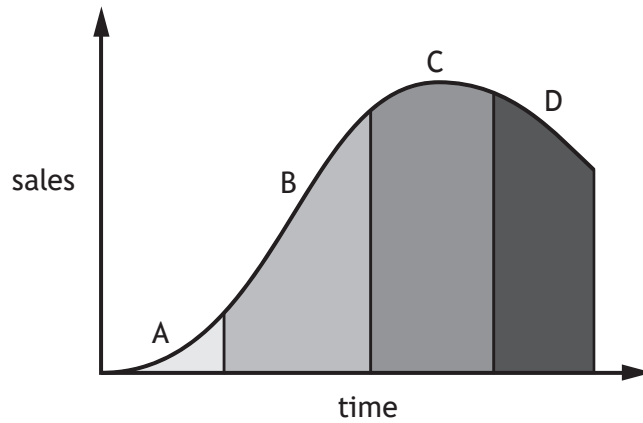

- (b) State the name of **one** stage of the product cycle and describe the role of the design engineer at that stage.

3

Stage	Name of Stage

7. (continued)

A student investigating the drone produces a drive system like the one shown below.

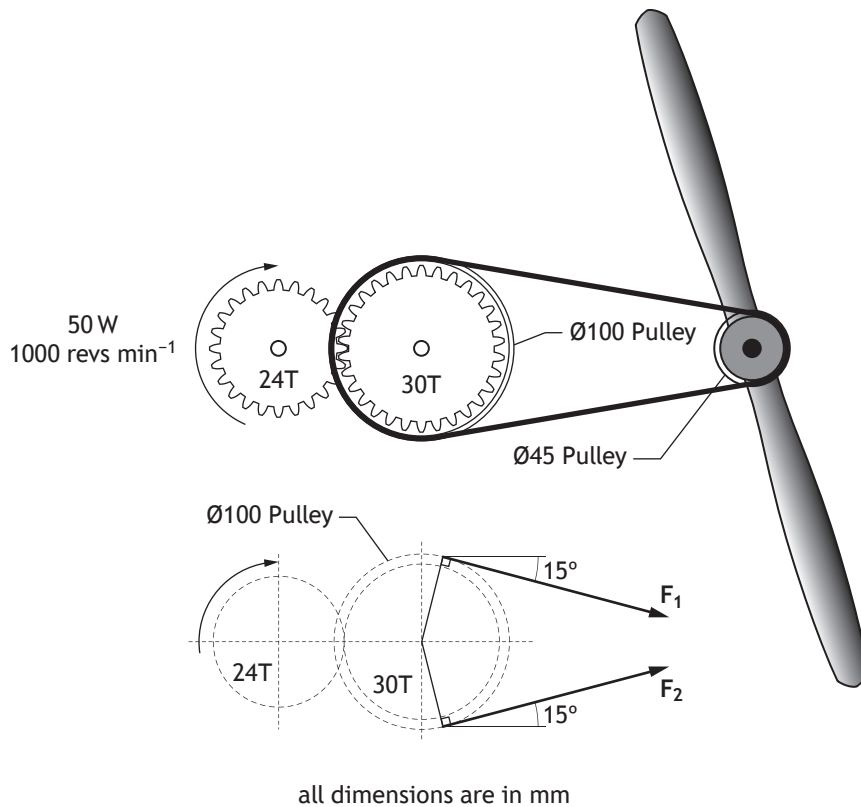

Assume that power transmission from the spur gear to the belt is 100% efficient. When the motor shaft speed is 1000 revs min⁻¹, the tension in the slack side of the belt is 20% of the tension in the tight side of the belt.

(c) Calculate the forces F_1 and F_2 .

4

7. (c) (continued)



* X 7 2 3 7 7 0 1 2 1 *

8. New support bearings are being installed under a concrete bridge section. During the works, hydraulic cylinders are used to temporarily support the bridge deck. The total self-weight of the bridge deck section is 90 kN.

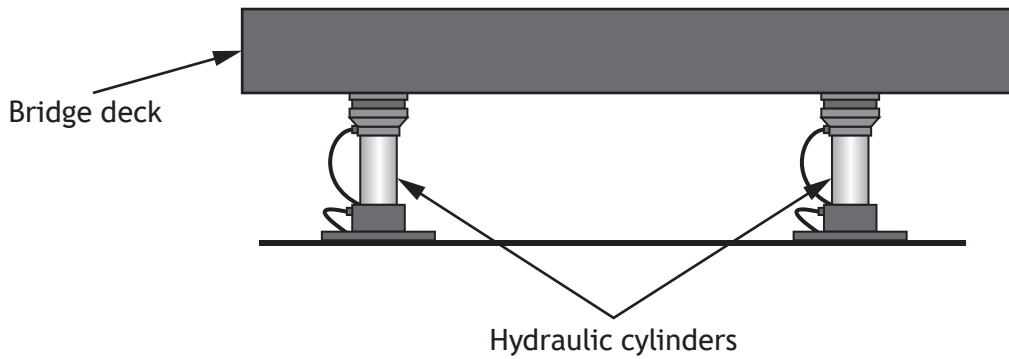

The free-body diagram below shows the forces acting on the supported bridge deck. The weight of the concrete is evenly distributed.

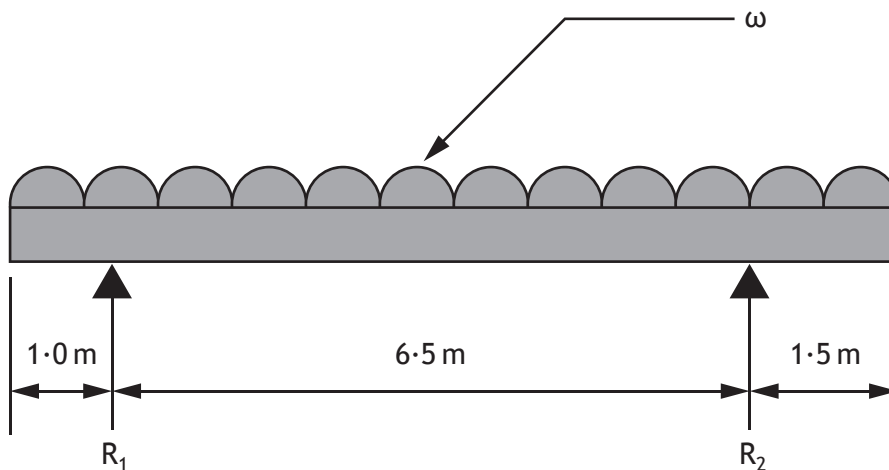

8. (continued)

MARKS DO NOT WRITE IN THIS MARGIN

- (a) Draw the Shear Force Diagram, showing values at all significant points. Use the box below the graph for calculations.

5

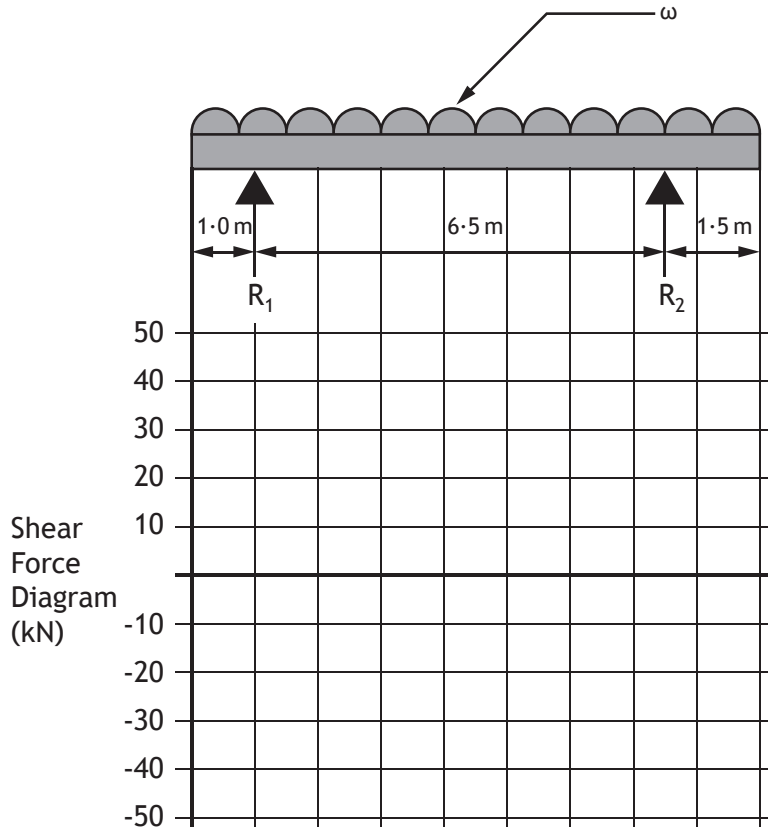

8. (continued)

The maximum bending moment occurs at a point between R_1 and R_2 .

- (b) Calculate its position, relative to the left-hand end of the beam, and its magnitude.

3



* X 7 2 3 7 7 0 1 2 4 *

8. (continued)

- (c) Complete the table of results for the bending moment at the points indicated. Use the box below the table for calculations.

2

Distance from left-hand end (m)	0	1	7.5	9
Bending Moment (kNm)				



* X 7 2 3 7 7 0 1 2 5 *

8. (continued)

A student is designing a system to control the lifting of a concrete beam using two hydraulic cylinders.

The system uses a microcontroller to switch hydraulic inlet valves on and off on each cylinder, in order to keep the beam level within a tolerance as the cylinders move. Position sensors on each cylinder provide feedback to the microcontroller.

The diagram below shows the main sub-systems.

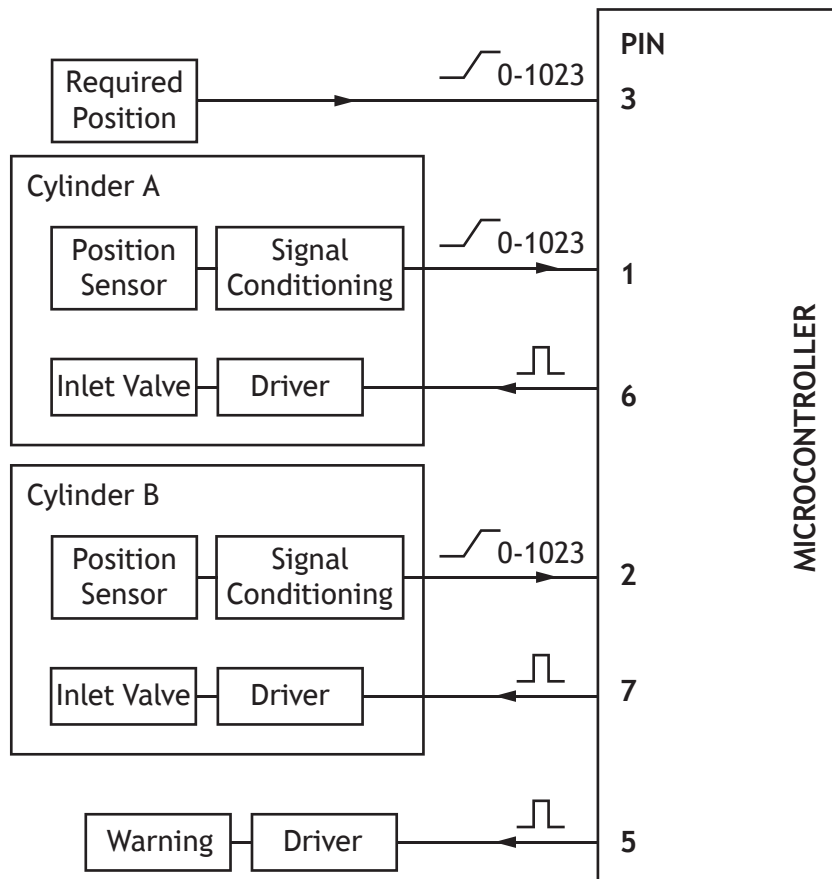

The student writes a program to control the system. The table below shows the main variables used.

Variable Name	Description
tol	Allowable difference or tolerance between the position of cylinder A and cylinder B
diff	Difference between the position of the two cylinders
pos_req	Required position of the two cylinders
pos_A	Actual position of cylinder A
pos_B	Actual position of cylinder B



* X 7 2 3 7 7 0 1 2 6 *

8. (continued)

DO NOT
WRITE IN
THIS
MARGIN

A version of the program in BASIC and Arduino is given below.

BASIC	ARDUINO
<pre> let tol=2 main: readadc10 B.3, pos_req readadc10 B.1, pos_A readadc10 B.2, pos_B if pos_A<pos_req AND pos_B<pos_req then lower=pos_B-tol upper=pos_B+tol diff=pos_A-pos_B Section A if diff=<tol then low B.5 high B.6 high B.7 else if pos_A>upper then high B.5 low B.6 high B.7 Section B else high B.5 high B.6 low B.7 Section C endif else low B.5 low B.6 low B.7 endif goto main </pre>	<pre> tol=2; void loop() { pos_req = analogRead(3); pos_A = analogRead(1); pos_B = analogRead(2); if pos_A<pos_req && pos_B<pos_req) { lower=pos_B-tol; upper=pos_B+tol; diff=pos_A-pos_B; Section A if (diff=<tol) { digitalWrite(5, LOW); digitalWrite(6, HIGH); digitalWrite(7, HIGH); } else if (pos_A>upper) { digitalWrite(5, HIGH); digitalWrite(6, LOW); digitalWrite(7, HIGH); } Section B else { digitalWrite(5, HIGH); digitalWrite(6, HIGH); digitalWrite(7, LOW); } Section C } else { digitalWrite(5, LOW); digitalWrite(6, LOW); digitalWrite(7, LOW); } } </pre>



* X 7 2 3 7 7 0 1 2 7 *

8. (continued)

During testing, the student discovered that there was a problem with the single line in Section A, causing the system not to be controlled correctly.

As a result, the faulty line in Section A was replaced with the following lines.

BASIC	ARDUINO
<pre> if pos_A>pos_B then diff=pos_A-pos_B else diff=pos_B-pos_A endif </pre>	<pre> if (pos_A>pos_B) { diff=pos_A-pos_B; } else { diff=pos_B-pos_A; } </pre>

- (d) Explain, making reference to the beam and the cylinders, the problem the original line caused; why the original line caused the problem and how the replacement lines corrected it.

3

MARKS

DO NOT
WRITE IN
THIS
MARGIN

ADDITIONAL SPACE FOR ANSWERS AND ROUGH WORK



* X 7 2 3 7 7 0 1 3 0 *

MARKS

DO NOT
WRITE IN
THIS
MARGIN

ADDITIONAL SPACE FOR ANSWERS AND ROUGH WORK



* X 7 2 3 7 7 0 1 3 1 *

ACKNOWLEDGEMENT

Section 1 Question 6 – Philip Lange/shutterstock.com

Section 2 Question 7 – Stock image/shutterstock.com



* X 7 2 3 7 7 0 1 3 2 *