

FOR OFFICIAL USE



National
Qualifications
2017

Mark

X723/77/01

Engineering Science

THURSDAY, 25 MAY

1:00 PM – 3:00 PM



* X 7 2 3 7 7 0 1 *

Fill in these boxes and read what is printed below.

Full name of centre

Town

Forename(s)

Surname

Number of seat

Date of birth

Day

Month

Year

Scottish candidate number

Total marks — 60

You may refer to the **Advanced Higher Engineering Science Data Booklet**.

SECTION 1 — 30 marks

Attempt ALL questions.

SECTION 2 — 30 marks

Attempt ALL questions

Write your answers clearly in the spaces provided in this booklet. Additional space for answers is provided at the end of this booklet. If you use this space you must clearly identify the question number you are attempting.

Show all working and units where appropriate.

The number of significant figures expressed in a final answer should be equivalent to the least significant data value given in the question. Answers that have two more figures or one less figure than this will be accepted.

Use **blue** or **black** ink.

Before leaving the examination room you must give this booklet to the Invigilator; if you do not, you may lose all the marks for this paper.



* X 7 2 3 7 7 0 1 0 1 *

SECTION 1 — 30 marks

Attempt ALL questions

1. An engineer is compiling a list of costs for a forthcoming civil engineering project.
- Construction materials
 - Employer National Insurance contributions
 - Earth moving machinery
 - Design consultancy expenses
 - Travelling expenses of engineers and technicians
 - Employer pension contributions
 - Rent and rates for administration office
 - Office supplies
 - Public liability insurance
 - Preliminary site work (to ensure compliance with Health & Safety legislation)
 - Engineering, technical and construction worker salaries
- (a) Identify one **indirect** and one **on-cost** from the list above and use the examples chosen to explain what is meant by each term.

3

1. (continued)

(b) The project involves the construction of a new road. The engineer draws up a table of tasks, times and precedents as shown below.

| | Task | Precedent(s) | Time (days) |
|---|------------------------------|--------------|-------------|
| A | Site clearance | None | 2 |
| B | Strip top soil | A | 3 |
| C | Lay culvert pipes & ducting | B | 3 |
| D | Lay sub-base | C | 4 |
| E | Lay surface layer (pavement) | D | 4 |
| F | Pull through power cables | C | 2 |
| G | Install street lighting | F | 4 |
| H | Erect road signs | A | 1 |
| I | Landscape sidings | F & H | 2 |

Complete the Gantt chart below for this project.

2

| Task | Time (days) | | | | | | | | | | | | | | | |
|------|-------------|---|---|---|---|---|---|---|---|----|----|----|----|----|----|----|
| | 1 | 2 | 3 | 4 | 5 | 6 | 7 | 8 | 9 | 10 | 11 | 12 | 13 | 14 | 15 | 16 |
| A | A | A | | | | | | | | | | | | | | |
| B | | | B | B | B | | | | | | | | | | | |
| C | | | | | | C | C | C | | | | | | | | |
| D | | | | | | | | | D | D | D | D | | | | |
| E | | | | | | | | | | | | | E | E | E | E |
| F | | | | | | | | | | | | | | | | |
| G | | | | | | | | | | | | | | | | |
| H | | | | | | | | | | | | | | | | |
| I | | | | | | | | | | | | | | | | |

[Turn over



* X 7 2 3 7 7 0 1 0 3 *

2. The Danish government hopes to achieve its goal of independence from fossil fuels by the year 2050. Denmark has no plans for Nuclear power and it cannot generate significant Hydropower, but it can import this form of electricity from Sweden and Norway.

The following extract is taken from a magazine published by the Danish Wind Industry Association & Offshoreenergy.dk.

Green transition with offshore wind

Three decades successfully integrating wind energy into the power system have given Denmark the know-how and confidence to not only wave goodbye to all fossil fuel use but set a deadline for doing so.

Today the country is building a power system for tomorrow. By 2035 offshore wind is to be the single largest contributor to electricity and heating in Denmark. Wind will be meeting 75% of demand for heat and power, with just over half of that coming from offshore capacity. Solar and other renewables will provide the remainder. The country’s electricity system operator, Energinet.dk, is already investing in the power system structure needed. The national energy political goal, agreed to by a large parliamentary majority, is independence from fossil fuel by 2050, including for transport.

- (a) Discuss the environmental, social and economic impacts which may result if the Danish government achieves its goal of independence from fossil fuels.

3



2. (continued)

(b) The Danish energy system operator, Energinet.dk, will have to meet base and peak load demands on a system entirely dependent on renewable energy sources.

Discuss an engineering challenge and possible solution that Energinet.dk will have to consider.

2

[Turn over

3. A mild steel wire of diameter 0.794 mm is bent around a drum of diameter 500 mm, as shown below.

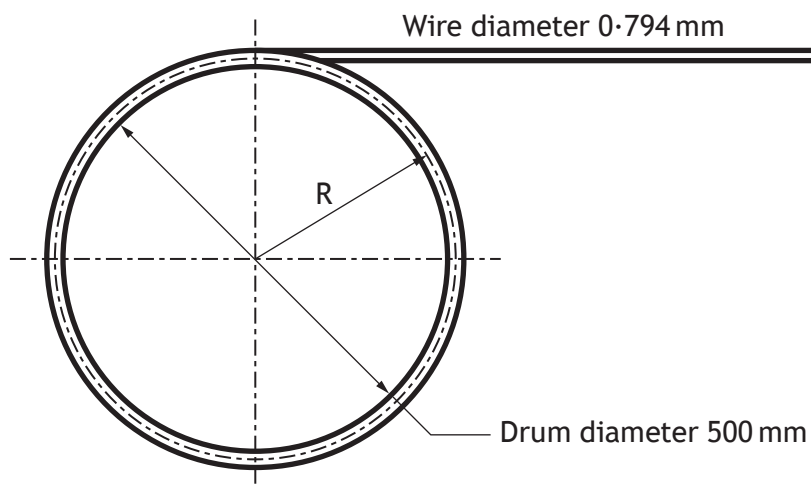

The radius, R , is measured to the centre line of the wire.

Calculate the maximum bending stress in the wire.

3



* X 7 2 3 7 7 0 1 0 6 *

4. A student wishes to estimate the second moment of area of an aerofoil section and decides that the best approximation using standard shapes is a semicircle, a rectangle and two identical right-angled triangles, as shown below.

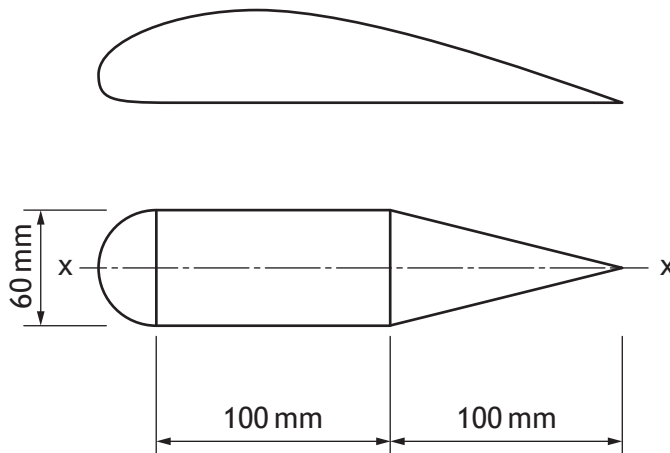

The second moment of area of a right-angled triangle about its base is given by:

$$I_{base} = \frac{bh^3}{12}$$

where b and h are base and height dimensions respectively. Note that the base of a right-angled triangle lies along axis $x - x$.

Calculate the second moment of area of the section about axis $x - x$ as shown. 4



5. A student is testing the circuit, shown below, for a control application.

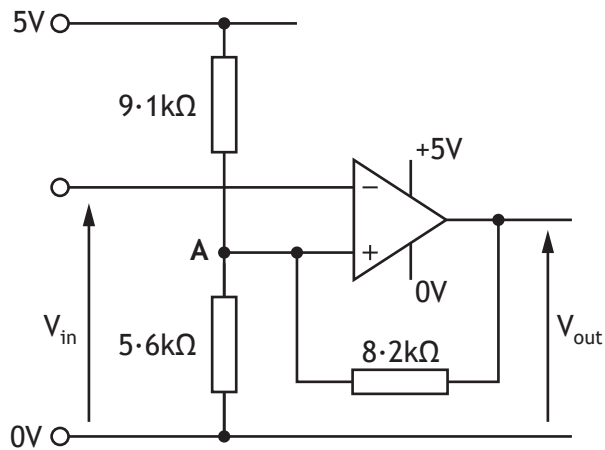

The op-amp output saturation voltages V_{out} are 3.5 V and 0.2 V .

Calculate the upper and lower threshold voltages at point A using nodal analysis.

5



DO NOT
WRITE IN
THIS
MARGIN

5. (continued)

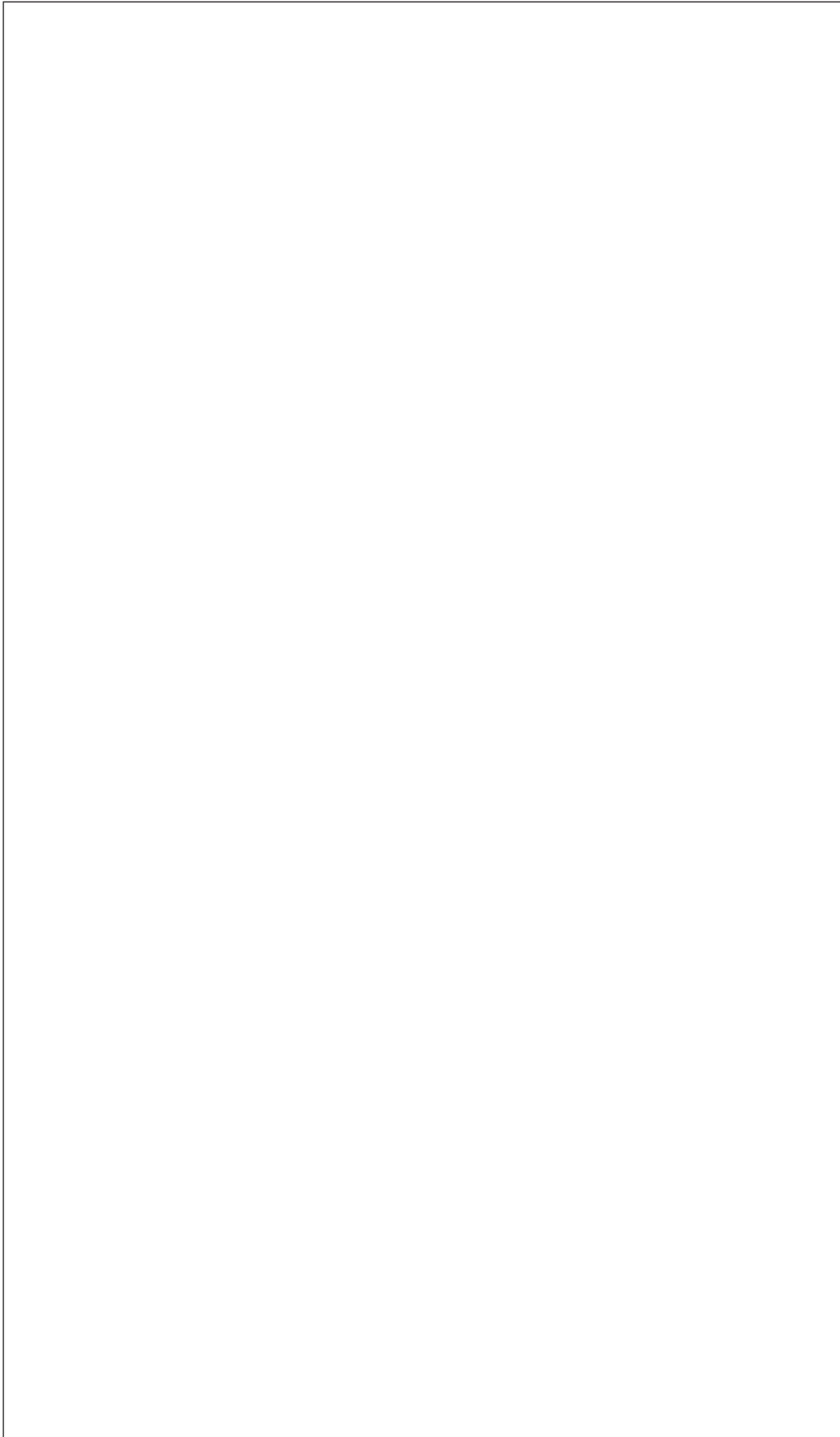

6. An office chair is supported by five roller feet on a diameter of 600 mm. The five legs and central pillar are a single moulded piece of polypropylene. The central pillar has outside diameter 50 mm. A maximum load of 120 kg is applied vertically to the seat.

A diagram of one of the legs is shown below.

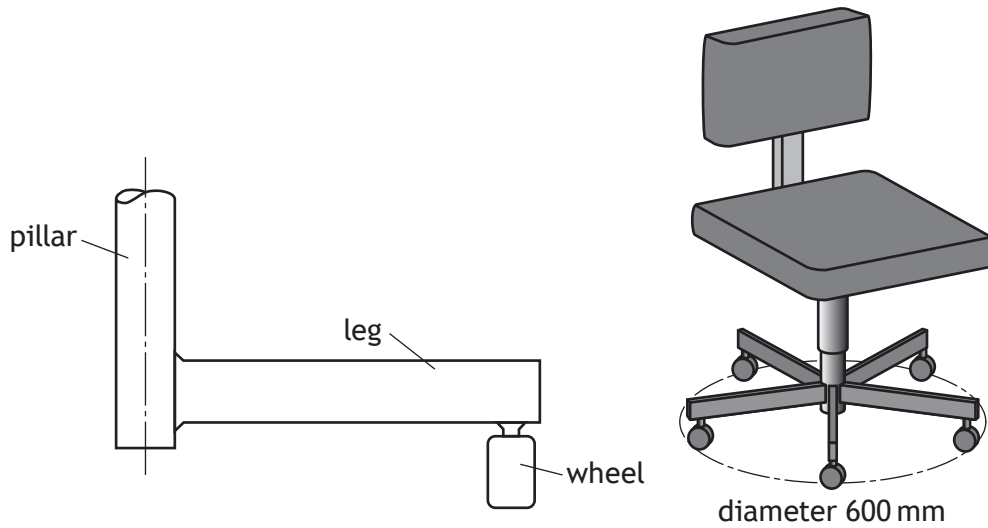

Each leg has a standard hollow rectangular cross-section 50 mm × 30 mm and wall thickness 3.2 mm.

Calculate the vertical deflection of the chair under the applied load.

3

[Turn over for next question

DO NOT WRITE ON THIS PAGE



* X 7 2 3 7 7 0 1 1 1 *

7. A pulley works due to static friction between the cable and the pulley; the load applied (tensions in the cable) and the amount of contact between the cable and the pulley are important. If there is insufficient tension (on both the tight and slack side) then the cable will slip. The equation used to determine the minimum ratio between the two cable tensions is:

$$\frac{F_1}{F_2} = e^{\mu\theta}$$

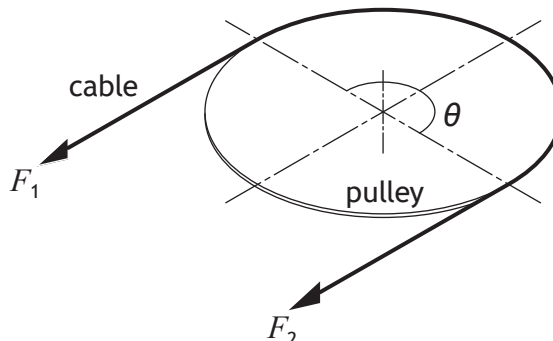

where,

F_1 = tight tension (N)

F_2 = slack tension (N)

μ = coefficient of (static) friction

θ = angle of contact between pulley and cable (radians)

The cable-driven pulley system, shown above, has the following conditions;

$$F_1 = 1000 \text{ N}$$

$$\mu = 0.3$$

$$\text{Pulley speed} = 955 \text{ revs min}^{-1}$$

$$\text{Pulley diameter} = 150 \text{ mm}$$

Note: 2π radians = 360° and the cable is in contact with half the circumference of the pulley.

- (a) Calculate the maximum power that can be transmitted under these conditions.

3

7. (a) (continued)



(b) Explain the effect on maximum transmissible power of an increase to either the coefficient of friction or the contact angle between the pulley and the cable.

2

[Turn over



SECTION 2 — 30 marks

Attempt ALL questions

8. A structural beam is part of the floor structure of a new public building. The applied loads arise from internal construction and architectural features, as shown below.

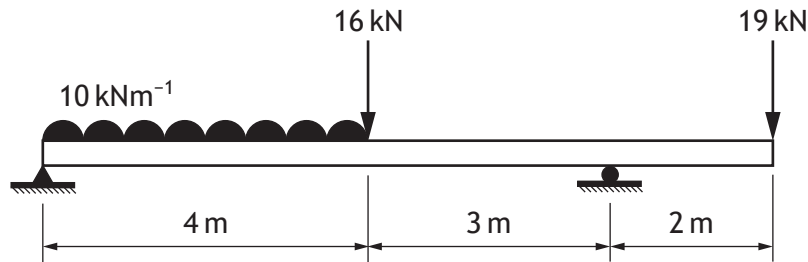

- (a) Sketch the Shear Force diagram for the beam.

4

Space for Working

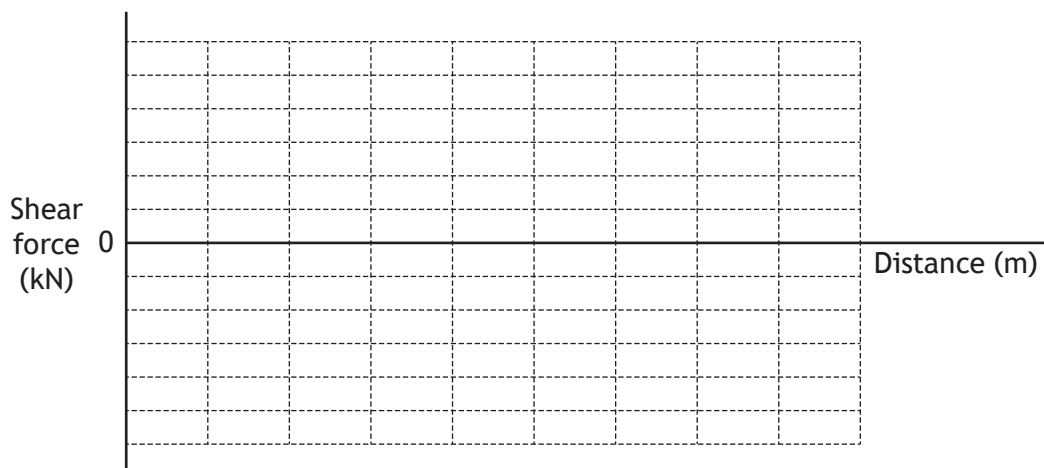

8. (continued)

(b) Write equations for the bending moment as a function of the distance, x , measured in metres from the left-hand end of the beam when:

(i) $0 \leq x \leq 4$

1

(ii) $4 \leq x \leq 7$

1

(c) Calculate the magnitude of the maximum bending moment and its position, measured from the left-hand end of the beam.

3



8. (continued)

The windows in the building use a special glass with integrated film which allows the transparency to be controlled electronically. The windows use an emerging technology called suspended particle device (SPD) glass.

SPD Glass
 Input Power Supply: 0 – 100V AC
 Transparency varies linearly:
 0V = Opaque
 100V = Fully Transparent

The control system uses a microcontroller, a digital to analogue converter (DAC) and a variable voltage power inverter to control the SPD film's transparency. A block diagram of the DAC and power inverter is shown below.

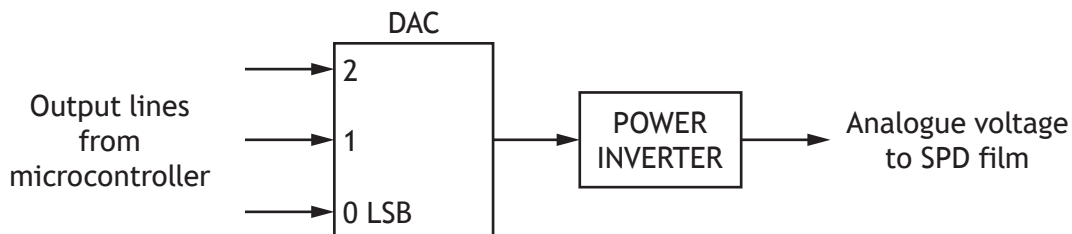

(d) Explain the need for the power inverter in this system.

2

(e) The DAC has the following specification.

- It should be built from operational amplifiers and resistors
- The microcontroller outputs are each 5V or 0V
- The maximum output from the DAC should be 7.5V
- The system power supply is $\pm 9V$ with op-amp saturation voltages of $\pm 7.5V$



8. (e) (continued)

Draw a complete circuit diagram for the DAC specified above, including all significant component values. **Show all working.**

4

Space for Working

Circuit Diagram



* X 7 2 3 7 7 0 1 1 7 *

9. A student project involves the design of an electric wheelchair, propelled by two brushless DC motors. Each motor has three coils which are energised in a sequence turning the central rotor. One method of producing the coil switching sequence is illustrated in the diagram below.

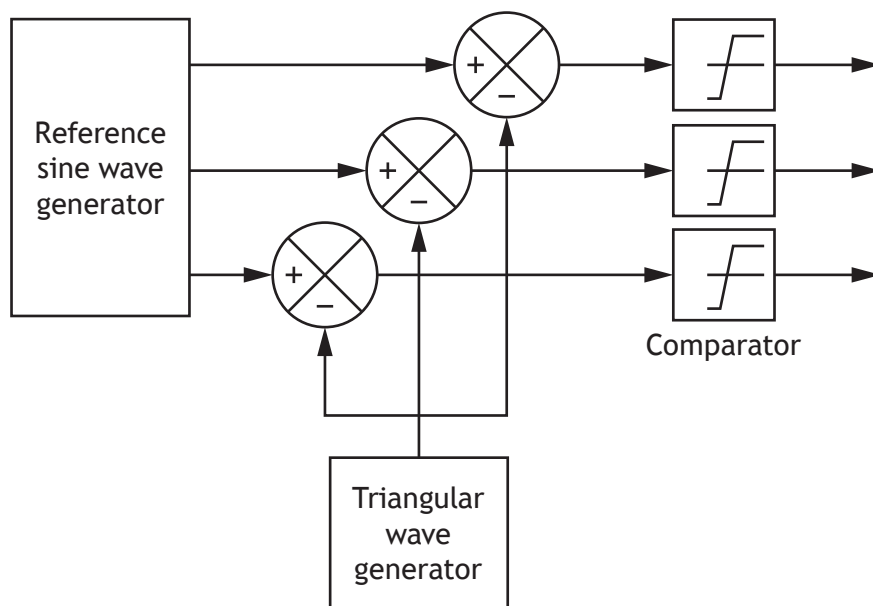

- (a) The sine wave and triangular wave are combined by the comparator to produce a coil switching waveform.

A Wien Bridge oscillator is used to generate a 50 Hz sine wave.

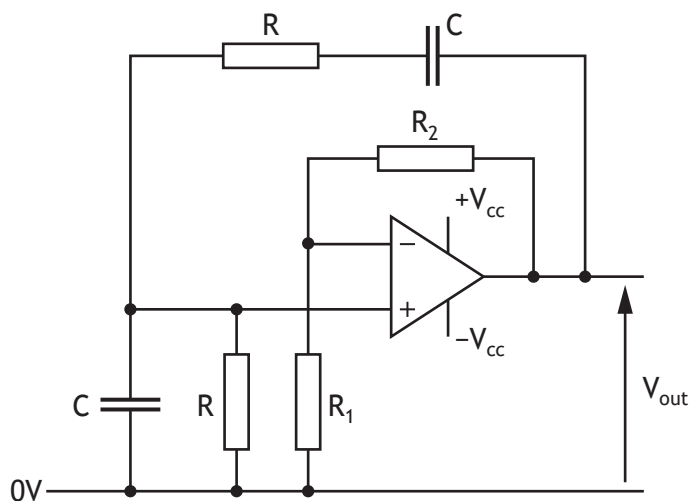

Calculate suitable values for R , C , R_1 and R_2 .

3



9. (a) (continued)

[Turn over



* X 7 2 3 7 7 0 1 1 9 *

9. (continued)

(b) The following circuit produces the waveforms shown below.

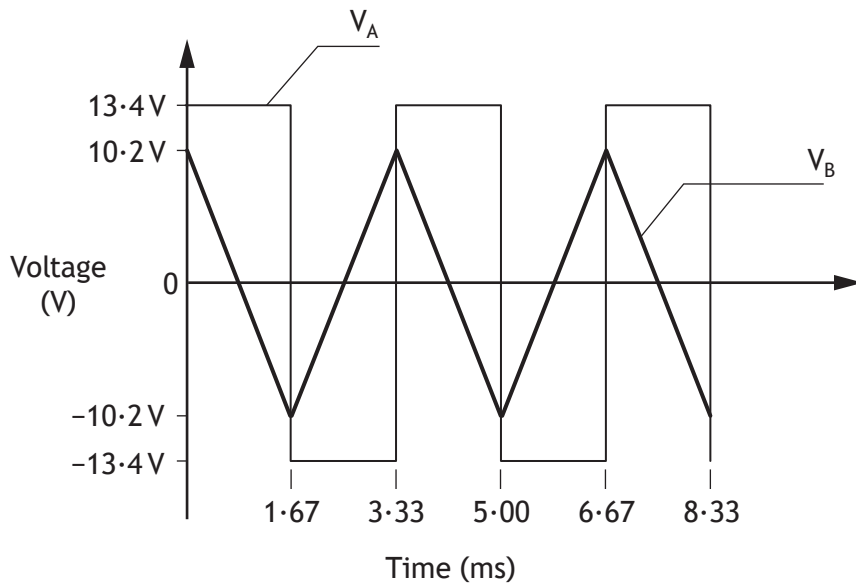
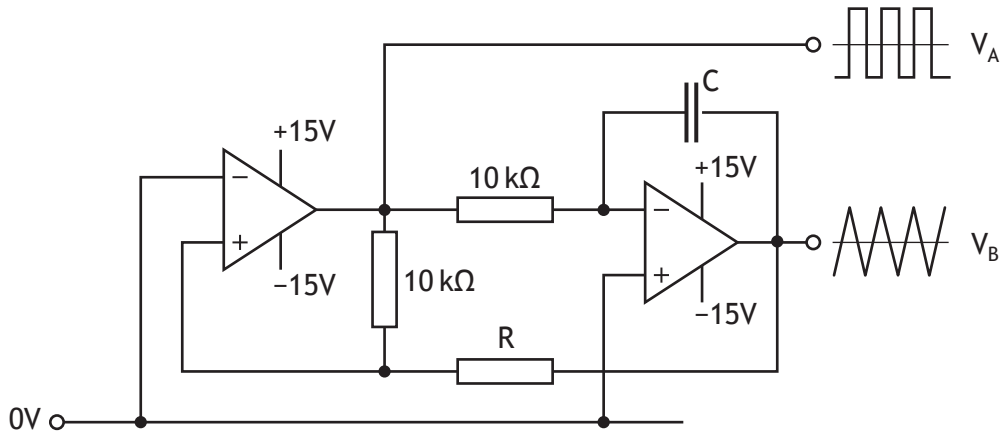

* X 7 2 3 7 7 0 1 2 0 *

9. (b) (continued)

Calculate the value of C and R by referring to the circuit and the waveform diagrams on *Page 20*.

3

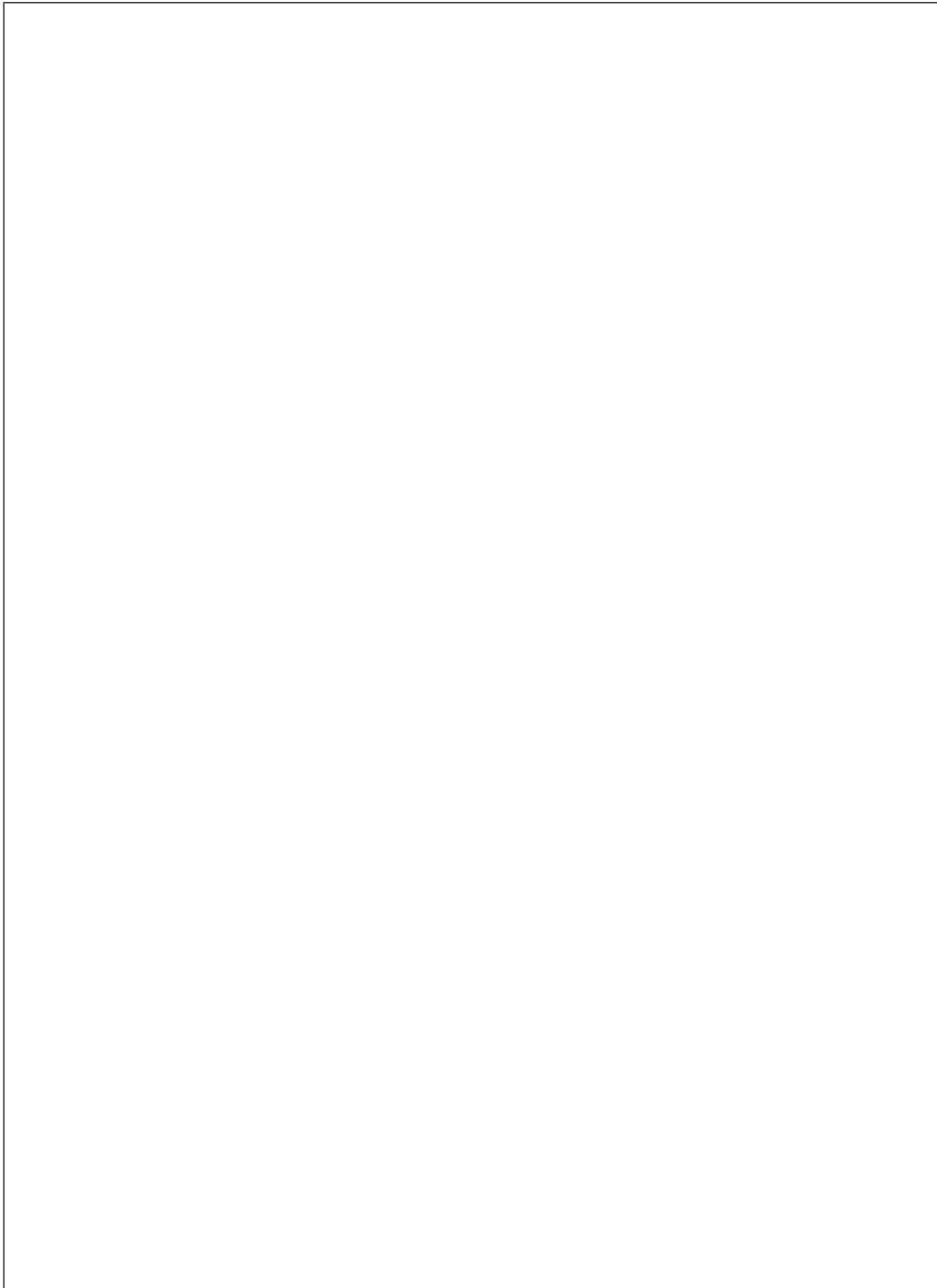

[Turn over



* X 7 2 3 7 7 0 1 2 1 *

9. (continued)

The prototype design for the drive of the wheelchair incorporated a single motor on a separate shaft from the wheel connected by a belt and pulley system as shown.

- (c) The shaft is supported on two roller bearings at A and B. The motor has a self-weight of 75 N and the belt tensions are 2350 N and 572 N. The slack side of the belt lies at 30° to the horizontal.

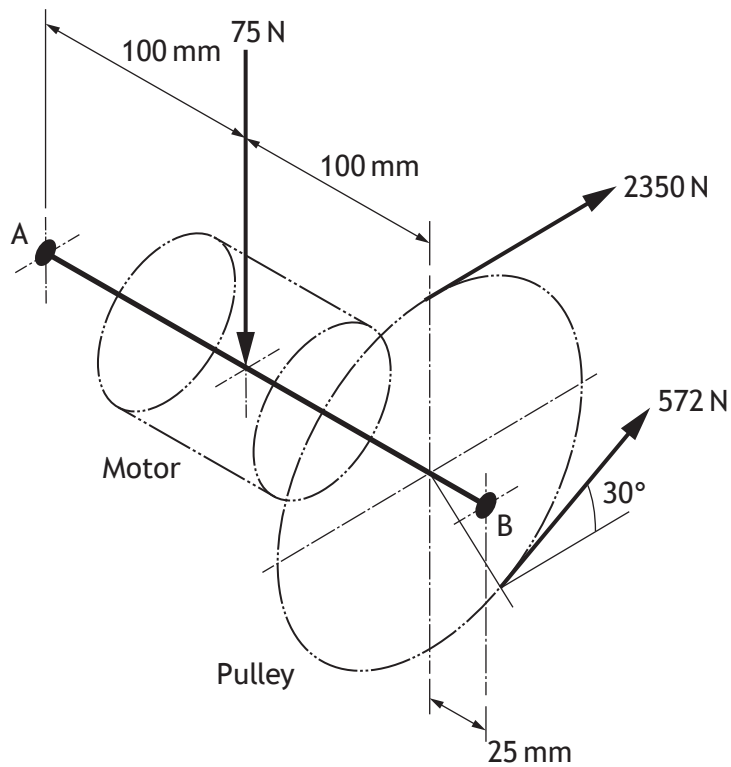

* X 7 2 3 7 7 0 1 2 2 *

MARKS

DO NOT
WRITE IN
THIS
MARGIN

9. (c) (continued)

Calculate the magnitude and direction of the force acting on bearing B.

5



* X 7 2 3 7 7 0 1 2 3 *

9. (continued)

DO NOT
WRITE IN
THIS
MARGIN

- (d) The student develops the prototype using a DC motor and writes two sub-procedures to control the motor speed. The target speed is set by a potentiometer and the actual speed is sensed using an optical speed sensor which produces a DC output in the range 0-5V, as shown in the diagram below.

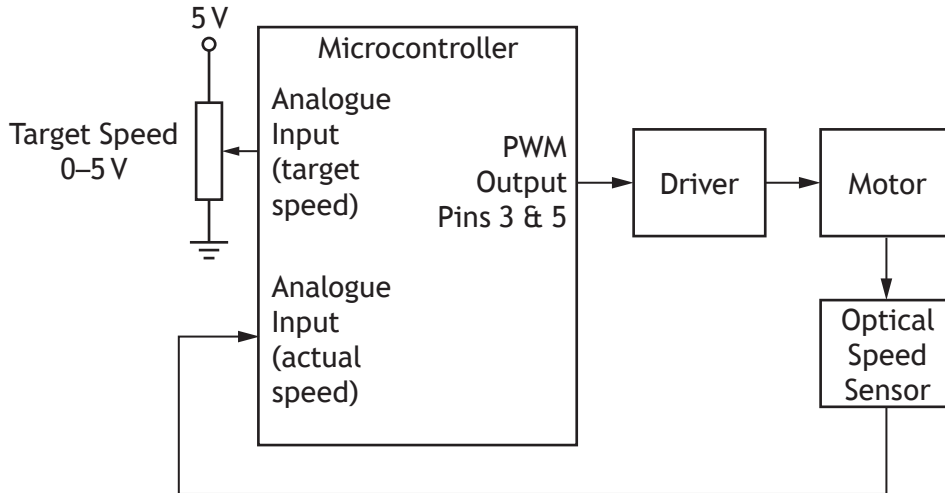

For an Arduino system, analogue pins 0 (target speed) and 1 (actual speed) are used for the analogue inputs.

For a PBASIC system, analogue channels B.0 (target speed) and B.1 (actual speed) are used for the analogue inputs.

- (i) Sub-procedure A, shown on *Page 25*, is called if the wheelchair is stationary or if the speed has dropped below a minimum value.

The following information is provided for reference.

| ARDUINO | PBASIC |
|--|--|
| <p>Command analogWrite()</p> <p>Description Writes a PWM signal to a pin until the next call to analogueWrite() or digitalWrite() on the same pin.</p> <p>Syntax analogWrite(pin, value)</p> <p>Parameters pin: a variable/constant which is the pin to write to value: the duty cycle: between 0 (off) and 255 (fully on)</p> | <p>Command pwmout</p> <p>Description Writes a continuous PWM signal to a pin until another pwmout command is sent to the pin.</p> <p>Syntax pwmout pin, period, mark</p> <p>Parameters pin: a variable/constant which is the pin to write to period: set to 255 for this application mark: the duty cycle: between 0 (off) and 1023 (fully on)</p> |



* X 7 2 3 7 7 0 1 2 4 *

9. (d) (i) (continued)

MARKS DO NOT WRITE IN THIS MARGIN

```
ARDUINO
void sub_procedure_A()
{
  for(int x=1; x<=50; x++)
  {
    duty = x;
    for(int y=1; y<=x; y++)
    {
      analogWrite(3, duty);
      analogWrite(5, 0);
      delay (1);
    }
  }
}
```

```
PBASIC
sub_procedure_A:

  for x = 1 to 50

    duty = x * 4
    for y = 1 to x

      pwmout B.3, 255, duty
      pwmout B.5, OFF
      pause 1
    next y
  next x

return
```

Sketch the graph of the motor speed that results from running sub-procedure A.

2

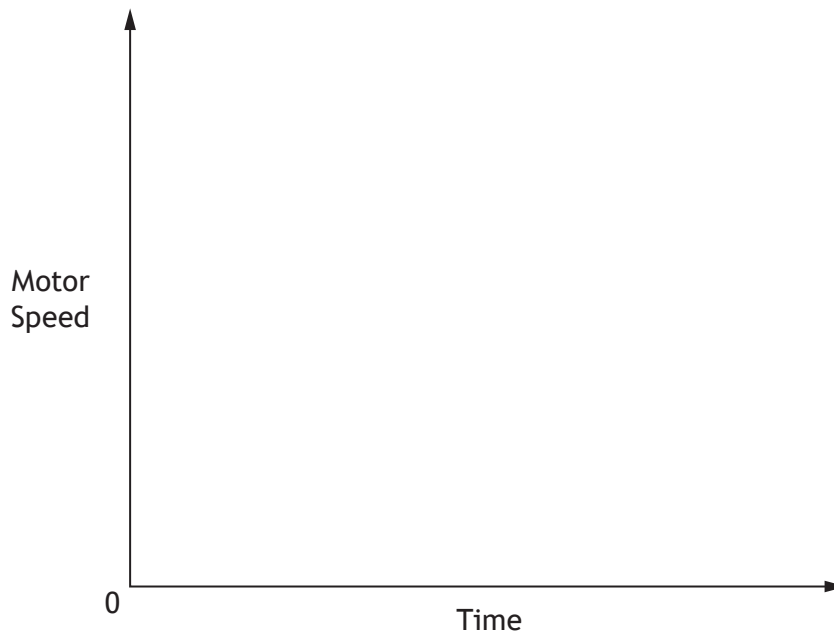

9. (d) (continued)

- (ii) The student writes sub-procedure B shown below, to control the wheelchair at speeds above the minimum value.

The following information is provided for reference.

DO NOT
WRITE IN
THIS
MARGIN

| ARDUINO | PBASIC |
|--|--|
| <p>Command constrain</p> <p>Description Restricts a number within a range</p> <p>Syntax constrain (<i>x</i>, <i>a</i>, <i>b</i>)</p> <p>Parameters <i>x</i>: a variable/constant which is to be restricted <i>a</i>: lower end of the range <i>b</i>: upper end of the range</p> <p>Returns <i>x</i>: if $a < x < b$ <i>a</i>: if $x < a$ <i>b</i>: if $x > b$</p> | <p>Mathematical Functions max</p> <p>Description max: limit a value to a maximum value</p> <p>Example for max let $x = y * 33 \text{ max } 255$</p> <p>Returns <i>x</i>: if $y * 33 < 255$ 255: if $y * 33 > 255$</p> |

ARDUINO

```
void sub_procedure_B()
{
  target = analogRead(0)/4;
  actual = analogRead(1)/4;
  if(target > actual)
  {
    error = target - actual;
    duty = constrain(error * gain, 0, 255);
  }
  else
  {
    duty = 0;
  }
  analogWrite(3, duty);
  analogWrite(5, 0);
}
```

PBASIC

```
sub_procedure_B:
  readadc B.0, target
  readadc B.1, actual
  if target > actual then

    error = target - actual
    duty = error * gain max 1023

  else

    duty = 0

  endif
  pwmout B.3, 255, duty
  pwmout B.5, OFF

return
```



9. (d) (ii) (continued)

Assume that the value of variable '*gain*' has previously been set by the student in the main part of the program.

Explain, with reference to sub-procedure B, why the wheelchair does not reach the target speed but instead, accelerates and settles at a lower speed with a steady-state error.

2

[END OF QUESTION PAPER]



* X 7 2 3 7 7 0 1 2 7 *

ADDITIONAL SPACE FOR ANSWERS AND ROUGH WORK



* X 7 2 3 7 7 0 1 2 8 *

ADDITIONAL SPACE FOR ANSWERS AND ROUGH WORK



* X 7 2 3 7 7 0 1 2 9 *

[BLANK PAGE]

DO NOT WRITE ON THIS PAGE



[BLANK PAGE]

DO NOT WRITE ON THIS PAGE



* X 7 2 3 7 7 0 1 3 1 *

[BLANK PAGE]

DO NOT WRITE ON THIS PAGE

Acknowledgement of Copyright

Question 2 Article is adapted from “Green transition with offshore wind” by Karin Jensen, taken from EWEA Offshore 2015 Special. Reproduced by kind permission of First Purple Publishing.

Question 2 Reference to Engerginet.dk is reproduced by kind permission of Energinet.dk.



* X 7 2 3 7 7 0 1 3 2 *