

N5

National 5
Coursework
Assessment Task



National 5 Practical Metalworking Practical activity Assessment task: garden lantern

Specimen – valid from session 2017-18 and until further notice.

This edition: November 2017 (version 1.0)

The information in this publication may be reproduced to support SQA qualifications. This publication must not be reproduced for commercial or trade purposes. **This material is for use by teachers and lecturers.**

© Scottish Qualifications Authority 2012, 2017

Contents

Introduction	1
Instructions for teachers and lecturers	2
Recording documentation	6
Marking instructions	9
Instructions for candidates	19

Introduction

This document contains marking instructions and instructions for candidates for the National 5 Practical Metalworking practical activity. It must be read in conjunction with the course specification.

This practical activity has 70 marks out of a total of 130 marks available for the course assessment.

This is one of two course assessment components. The other component is a question paper.

Instructions for teachers and lecturers

This is a specimen assessment task.

SQA will publish a new assessment task on the secure website each academic year. The task is valid for that year only. Once complete, the practical activity is marked internally and marks are submitted to SQA.

The practical activity is issued in two stages:

Stage1: An initial simplified drawing, with a cutting list of the materials required. No details of the construction/methods of joining are provided at this time, only the overall sizes to assist with preparing the materials.

Stage 2: The complete working drawings for the practical activity, giving the construction/methods of joining and detailed dimensions for the component parts.

Although the practical activity is conducted under some supervision and control, a high degree of supervision is required for health and safety.

The practical activity must be carried out:

- ◆ without interruption by periods of learning and teaching
- ◆ in a workshop environment
- ◆ in time to meet the mark submission date set by SQA
- ◆ on an individual basis by the candidate (ie no group work is permitted)
- ◆ under supervision to ensure that work presented is the candidate's own
- ◆ under supervision to ensure a safe and controlled environment

Time

This practical activity is carried out over a period of time, starting at an appropriate point in the course, once all content has been delivered.

Resources

The practical activity is undertaken in open-book conditions and, as such, candidates can have access to learning and teaching materials, the internet, notes, exemplar materials, resources on classroom walls or anything similar while it is being undertaken.

The practical activity will include instructions for teachers, lecturers and candidates; this will detail any materials that they will need.

Reasonable assistance

Candidates are expected to progress through each stage of the practical activity independently, having acquired the skills earlier in the course. Assessors will only intervene during the practical activity to ensure the safe running of the workshop environment. Where this happens, it must be recorded and reflected in the marks awarded, in line with the marking instructions.

The practical activity is designed to discriminate between candidates. Once the practical activity has been completed, the product cannot be returned to a candidate for further work.

Reasonable assistance may be provided to ensure that:

- ◆ candidates have all the materials and equipment required to complete the practical activity
- ◆ candidates understand the information outlined in the instructions
- ◆ candidates' ongoing work is stored and distributed securely
- ◆ tools/equipment required by candidates are made available

Assessors must not give instructions on how to carry out the practical activity or complete an entry in a log book. They must not help to manufacture joints or component parts, or assist with setting up machinery or hand tools to carry out a process.

Evidence

Evidence for the assessment task includes:

- ◆ the completed product (and any candidate-created jigs)
- ◆ the completed log book
- ◆ a record of any intervention relating to independence of work
- ◆ a record of any intervention relating to safe working

All candidate evidence must be internally assessed.

Alteration or adaptation

The practical activity must not be altered, adapted or modified in any way (this includes moving the content of the practical activity into a different format or re-drawing/producing additional working drawings). The only exception to this is the thickness of the material used.

As it is sometimes difficult for centres to obtain specific thicknesses of material, teachers and lecturers are allowed to adjust the thicknesses relative to their situation. Any changes are subject to professional judgement, ie a 15mm thickness could be changed to 18mm or 12mm; however changing it to 5mm would not be appropriate.

Note: if centres do adjust the thickness, they **must** adjust the working drawings to reflect this.

Submission

Internally assessed marks must be submitted in line with SQA submission dates.

Volume

One completed log book and one completed product is required for each candidate. The log book is provided to centres as a separate file.

Specific instructions for teachers and lecturers

Teachers and lecturers must ensure that these specific instructions are followed. Candidates must be made aware of the assessment conditions and know what they should do to complete the practical activity.

Prior to starting the practical activity, teachers and lecturers must supply candidates with the unaltered working drawings provided by SQA, a log book, and the materials required to carry out the practical activity.

Once the product is made, candidates must prepare it for a finish to be applied. Candidates are not required to apply a finish.

While working on the practical activity, candidates must adhere to recognised safe working practices as well as those stipulated within their centre.

Specimen practical activity: garden lantern

The table below specifies areas in this practical activity where the functional sizes are assessed.

Candidates must be assessed using **five** of the suggested sizes in the table below, selecting at least **one** from **each** area. Assessors must indicate on the assessment record, which functional sizes have been selected for assessment.

Part	Functional sizes may be drawn from:
Handle	Overall length or drilling and internal threading of the hole (one example)
Supports	Distance from of the lowest edge of the support bracket to the centre of the handle mount hole or the centrality of the mount hole (one example)
Legs	Overall length or position and centrality of the hole or drilling and internal threading of the hole or dimension between legs (one example)
Feet	Overall length or centrality of the hole or drilling and internal threading of the hole (one example)

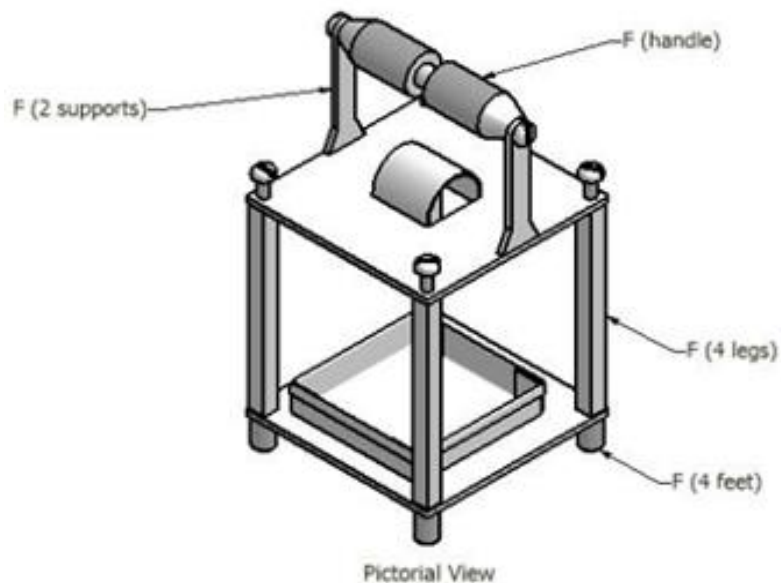

Recording documentation

The following document must be used by assessors to record the marks awarded to candidates.

National 5 Practical Metalworking: practical activity

Assessment record

Candidate name: _____ Class/group: _____

Candidate number: _____ Centre: _____

Practical activity title:			
Section	Max marks	Mark given	Assessor comments/explanation
Log book:			
◆ machine care and maintenance	5		
◆ tool care and maintenance	5		
◆ safe working procedures	5		
Bench work:			
◆ measuring and marking	4		
◆ cutting, shaping and forming (not machine parts)	4		
◆ independence of work	3		
Machining:			
◆ lathe work (accuracy of dimensions)	4		
◆ lathe work (quality of work)	4		
◆ machine drilling (lathe and pedestal/pillar drill)	4		
◆ independence of work	3		
Fabrication:			
◆ mechanical joints (riveting, threads, fold joints)	4		
◆ fusion joints (welding, brazing, soldering)	4		
◆ independence of work	3		
Finishing:			
◆ preparation	5		
◆ independence of work	3		
Overall assembly:			
◆ assembly	5		
◆ functional dimensions	5		
Total marks	70		

Please use the space provided below for any additional comments to support your assessment judgement. You may attach additional pages if required.

Assessor signature		Date	
-------------------------------	--	-------------	--

Marking instructions

The following marking instructions are applicable to this specimen assessment task and are helpful for those preparing candidates for course assessment.

Candidate evidence is internally assessed in line with SQA's marking instructions. Marking instructions are provided along with the annual practical activity assessment tasks.

General marking principles

This information is provided to help you understand the general principles that must be applied when marking candidate responses in this practical activity. These principles must be read in conjunction with the detailed/specific marking instructions, which identify the key features required in candidate responses.

- a Marks for each candidate response must **always** be assigned in line with these general marking principles and the detailed marking instructions for this assessment.
- b Marking should always be positive. This means that, for each candidate response, marks are accumulated for the demonstration of relevant skills, knowledge and understanding: they are not deducted from a maximum on the basis of errors or omissions.

Detailed marking instructions

Log book

The log book must be completed by all candidates and is worth a total of 15 marks. The log book consists of three areas, each worth 5 marks:

- ◆ machine/power tool care and maintenance
- ◆ tool care and maintenance
- ◆ safe working procedures

Machine care and maintenance (up to 5 marks)

Machine care and maintenance focuses on the procedure checks that are carried out on machine and power tools prior to, and following, their use. It also covers the procedures involved in setting up machinery to carry out specific tasks.

Each procedure check must cover all areas associated with that procedure. Checks must be carried out on machinery/power tools to an acceptable standard and accurately recorded in the log book.

One mark is available for each procedure check carried out, up to a maximum of 5 marks.

Example procedure checks are given below:

- ◆ setting up the pedestal drill for safe use (1 mark)
- ◆ setting the height of a cutting tool for safe use (1 mark)
- ◆ preparing the spot welder for safe use (1 mark)
- ◆ preparing the welding plant for safe use (1 mark)
- ◆ preparing the forge for safe use (1 mark)

These examples are not prescriptive. Centres are free to select any appropriate procedure checks on machinery/power tools that they carry out.

Tool care and maintenance (up to 5 marks)

Tool care and maintenance focuses on the procedures of repairing and setting of various hand tools. Each procedure must specify the issue, whether there is a repair required or the tool has to be set. These scenarios are open to centres to devise, but where possible, they should sit alongside learning and teaching.

Procedures must be carried out on tools to an acceptable standard and accurately recorded in log book.

One mark is available for each procedure carried out, up to a maximum of 5 marks. Example procedures are given below:

- ◆ replacing a hacksaw blade (1 mark)
- ◆ cleaning a flat file (1 mark)
- ◆ replacing a file blade (1 mark)
- ◆ securing a loose jaw in an engineer's vice (1 mark)
- ◆ storing tools (1 mark)

Safe working procedures (up to 5 marks)

Safe working procedures focuses on candidates' behaviour within a workshop, and their ability to adhere to general and centre-specific health and safety procedures and rules.

Assessors must note any interventions or reminders during the practical activity, and apply marks as outlined in the marking instructions.

These interventions or reminders could include:

- ◆ stopping unsafe use of a machine/power tool
- ◆ preventing unsafe use of hand tools
- ◆ unacceptable behaviour
- ◆ any breach of health and safety regulations
- ◆ any breach of the centre's procedures or rules

Candidate has adhered to safe working procedures, without any need for reminders or interventions	5
Candidate has adhered to safe working procedures, with one reminder or intervention	4
Candidate has adhered to safe working procedures, with two reminders or interventions	3
Candidate has adhered to safe working procedures, with three or four reminders or interventions	2
Candidate has adhered to safe working procedures, with regular reminders or interventions	1
Candidate has adhered to safe working procedures, with constant reminders or interventions	0
Total marks available	15 marks

Bench work

Measuring and marking (up to 4 marks)	
When making assessment judgements, assessors must consider how the component parts associated with bench work were measured and marked.	
Accurate use of measuring and marking tools has ensured that all instances of marking are within tolerance	4
Accurate use of measuring and marking tools has ensured that most instances of marking are within tolerance	3
Accurate use of measuring and marking tools has ensured that some instances of marking are within tolerance	2
Accurate use of measuring and marking tools has ensured that few instances of marking are within tolerance	1
There is no evidence of accurate use of measuring and marking tools	0
Cutting, shaping and forming – not machined parts (up to 4 marks)	
When making assessment judgements, assessors must consider how the component parts were cut, shaped and formed	
All cutting, shaping and forming of component parts are within tolerance	4
Most cutting, shaping and forming of component parts are within tolerance	3
Some cutting, shaping and forming of component parts are within tolerance	2
The cutting, shaping and forming of few of the component parts are within tolerance	1
There is no evidence that components have been cut, shaped or formed	0
Independence of work (up to 3 marks)	
For guidance on what is considered additional assistance, assessors must refer to the 'Guidance on conditions of assessment for coursework' document.	
In general, additional assistance is where assessors have demonstrated or described a procedure.	
All bench work has been carried out independently, with no additional assistance required	3
Bench work has been carried out independently, with one or two instances of assistance required	2
Bench work has been carried out, with regular assistance required	1
Bench work has been carried out, with constant assistance required	0
Total marks available	11 marks

Machining

Lathe work – accuracy of dimensions (up to 4 marks)	
When making assessment judgements, assessors must refer to the tolerances given in the assessment task, for all the component parts manufactured on lathe.	
All linear and radial dimensions are within tolerance	4
Most linear and radial dimensions are within tolerance	3
Some linear and radial dimensions are within tolerance	2
Few linear and radial dimensions are within tolerance	1
There is no evidence of linear or radial dimensions being within tolerance	0
Lathe work – quality of work (up to 4 marks)	
When making assessment judgements, assessors must relate to the standard expected at National 5 level:	
<ul style="list-style-type: none"> ◆ parallel cuts should be parallel ◆ taper turning should be consistent in cut ◆ step shoulders should be sharp ◆ knurling should be of a good standard ◆ facing work should be of good quality 	
All aspects of lathe work meet the standard	4
Most aspects of lathe work meet the standard	3
Some aspects of lathe work meet the standard	2
Few aspects of lathe work meet the standard	1
There is no evidence of lathe work	0
Machine drilling – lathe and pedestal/pillar drill (up to 4 marks)	
When making assessment judgements for machine drilling, assessors must consider:	
<ul style="list-style-type: none"> ◆ the positioning of centres for drilling ◆ the depth of holes ◆ deburring ◆ the alignment of holes, where appropriate ◆ countersinking, if required 	

All drilling on lathe or pedestal/pillar drill is within tolerance and, where applicable, aligned	4
Most drilling is within tolerance and, where applicable, aligned	3
Some drilling is within tolerance and, where applicable, aligned	2
Few instances of drilling are within tolerance	1
There is no evidence of drilling within tolerance	0
Independence of work (up to 3 marks)	
For guidance on reasonable assistance, assessors must refer to the 'Instructions for teachers and lecturers' section.	
In general, additional assistance is where assessors have to demonstrate or describe a procedure.	
All machining work has been carried out independently, with no additional assistance required	3
Machining work has been carried out independently, with one or two instances of assistance required	2
Machining work has been carried out, with regular assistance required	1
Machining work has been carried out, with constant assistance required	0
Total marks available	15 marks

Fabrication

Mechanical joints – riveting, internal and external threads, fold joints (up to 4 marks)	
When making assessment judgements for mechanical joints, assessors must relate to the standard expected at National 5 level:	
<ul style="list-style-type: none"> ◆ snapheads are properly formed ◆ countersink wells are filled ◆ external threads are smooth, with no breaks ◆ internal threads have been finished appropriately ◆ no evidence of drunken threads ◆ folded joints are crease-free ◆ folds are consistent and parallel 	
All mechanical joints meet the standard	4
Most mechanical joints meet the standard	3
Some mechanical joints meet the standard	2
Few mechanical joints meet the standard	1
There is no evidence of mechanical jointing	0
Fusion joints – welding, brazing, soldering (up to 4 marks)	
When making assessment judgements for fusion joints, assessors must check:	
<ul style="list-style-type: none"> ◆ the consistency of run over length of joint ◆ if lack of splatter is evident ◆ there is no evidence of burning ◆ that joints are square/in line ◆ that slag has been removed ◆ that there is no grinding of joints 	
All fusion joints demonstrate consistency of run, with no evidence of splatter	4
Most fusion joints demonstrate consistency of run, with no evidence of splatter	3
Some fusion joints demonstrate consistency of run, with no or little evidence of splatter	2
Few fusion joints demonstrate consistency of run, with little evidence of splatter	1
There is no evidence of fusion joints	0

Independence of work (up to 3 marks)	
<p>For guidance on what is considered additional assistance, assessors must refer to the 'Guidance on conditions of assessment for coursework' document.</p> <p>In general, additional assistance is where assessors have demonstrated or described a procedure.</p>	
All fabrication work has been carried out independently, with no additional assistance required	3
Fabrication work has been carried out independently, with one or two instances of assistance required	2
Fabrication work has been carried out, with regular assistance required	1
Fabrication work has been carried out, with constant assistance required	0
Total marks available	11 marks

Finishing

Preparation (up to 5 marks)	
<p>Marks are only allocated for preparing the component parts for a finish. Candidates must not apply any finish that obscures their work, such as paint or dip coating. A clear lacquer can be applied.</p> <p>A well prepared finish will have:</p> <ul style="list-style-type: none"> ◆ no scratches ◆ no evidence of reference lines ◆ no burrs on edges ◆ no uneven surfaces ◆ all marks from processing removed 	
All component parts have been well prepared for finish	5
All component parts have been well prepared for finish, with minor blemishes in one component part	4
Most component parts have been well prepared for finish	3
Some component parts have been well prepared for finish	2
Few component parts have been well prepared for finish	1
There is no evidence of preparation for finish	0
Independence of work (up to 3 marks)	
<p>For guidance on reasonable assistance, assessors must refer to the 'Instructions for teachers and lecturers' section.</p> <p>In general, additional assistance would likely be where assessors have to demonstrate or describe a procedure.</p>	
All finishing work has been carried out independently, with no additional assistance required	3
Finishing work has been carried out independently, with one or two instances of assistance required	2
Finishing work has been carried out, with regular assistance required	1
Finishing work has been carried out, with constant assistance required	0
Total marks available	8 marks

Overall assembly

Assembly (up to 5 marks)	
<p>When making assessment judgements, assessors must consider the assembly of component parts in conjunction with the overall assembly.</p> <p>To achieve a mark of 5, the product must be fully assembled. If not, then a mark should be awarded based on the quality and functionality of the partially assembled product.</p>	
All component parts have been correctly assembled and the product is functional	5
All component parts, with the exception of one, have been correctly assembled and the product is functional	4
Most component parts have been correctly assembled	3
Some component parts have been assembled	2
Few component parts have been assembled	1
There is no evidence of assembly	0
Functional dimensions (up to 5 marks)	
<p>Functional sizes are given in the assessment task. Assessors should ensure they are familiar with which five functional sizes they will be selecting for assessment purposes.</p> <p>These functional sizes must be consistent for all candidates within the group and candidates must be made aware of them prior to starting the assessment task.</p>	
All five identified functional dimensions are within tolerance	5
Four identified functional dimensions are within tolerance	4
Three identified functional dimensions are within tolerance	3
Two identified functional dimensions are within tolerance	2
One identified functional dimension is within tolerance	1
There is no evidence of any functional dimensions	0
Total marks available	10 marks

Instructions for candidates

This assessment applies to the practical activity for National 5 Practical Metalworking.

This practical activity has 70 marks out of a total of 130 marks available for the course assessment. After scaling of the question paper mark, this will represent 70% of the overall marks for the course assessment.

It assesses the following skills, knowledge and understanding:

- ◆ selecting and using a range of metalworking tools, equipment and materials
- ◆ reading, interpreting and following given working drawings, outline specification information and cutting lists
- ◆ marking out, cutting and shaping component parts
- ◆ fabricating and joining metalwork components
- ◆ manufacturing a finished product to given drawings and standards
- ◆ working and using tools and equipment in accordance with recognised procedures and safe working practices

This is an open-book assessment. Your teacher or lecturer will let you know how the assessment will be carried out and any required conditions for doing it.

In this practical activity, you have to:

- ◆ demonstrate skills and apply knowledge gained from the course
- ◆ use power, machine and hand tools, as specified, to manufacture a product
- ◆ prepare the product ready to apply a finish, although you will not be required to apply one
- ◆ adhere to recognised safe working practices, as well as those stipulated within your centre
- ◆ complete the log book issued by your teacher or lecturer

You are provided with:

- ◆ all working drawings required to manufacture the product
- ◆ materials required to manufacture the product
- ◆ all necessary machine, power and hand tools
- ◆ a log book

Submitting your work

Your teacher or lecturer will let you know the time you have available to manufacture the product.

Garden lantern

You will have the opportunity to demonstrate practical creativity in shaping the handle and assembly of the candle tray, however, this is not mandatory.

Jigs or templates created to manufacture the garden lantern must be included with your work, as they are used to inform assessment judgements.

You must complete the log book, as this attracts specific marks.

The following tolerances apply to this practical activity:

Operation	Tolerance
Individual components	
Marking out	± 0.5mm
Fitting work	± 0.5mm
Sheet metal work (cutting)	± 1mm
Bending work – sheet metal	± 2mm
Bending work – metal strip/bar	± 5mm
Forge processes (twisting, drawing down and flattening)	± 3mm
Assembly, joining and fitting	
Functional sizes	± 0.5mm linear
Thermal joining	Minimum length of 20mm consistent in width
Pedestal drill	
Drilling and countersinking	± 0.5mm
Centre lathe	
Parallel turning, facing and chamfering	± 0.5mm linear ± 0.2mm diameter

Garden lantern

The garden lantern shown consists of two main parts:
The main body has feet, an air vent and a handle with a grip.
A sheet tray is required to hold the candle and collect the dripping wax – details of the tray are shown in the final drawing.

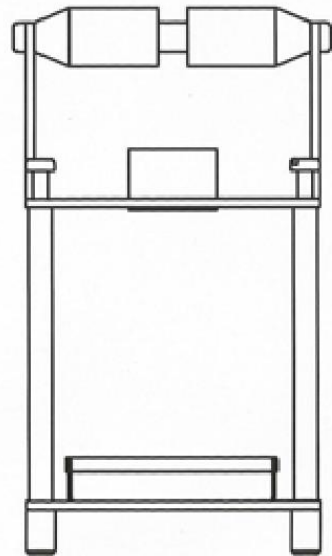

Elevation
SCALE 1 : 2

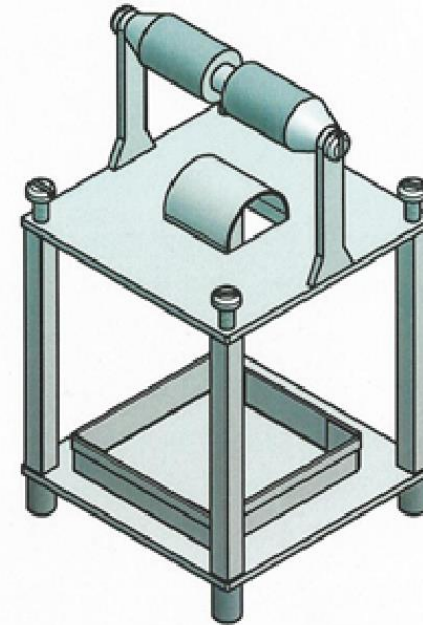

Pictorial View

National 5 Practical Metalworking		
GARDEN LANTERN	SCALE NTS	Drg. No.1

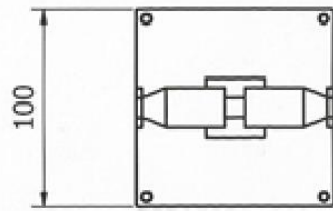

Plan

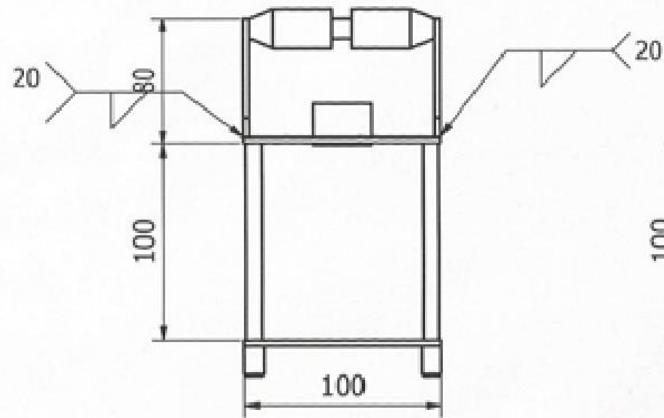
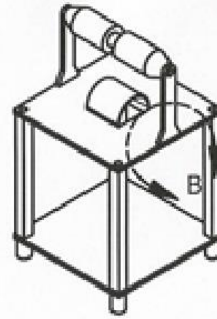

Elevation

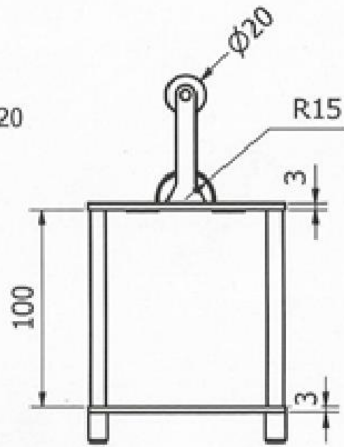

End Elevation

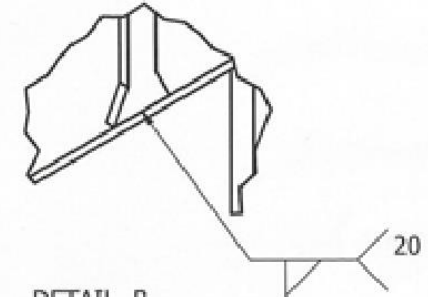

DETAIL B
SCALE 2 : 3

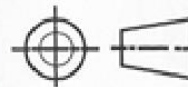

National 5 Practical Metalworking		
GARDEN LANTERN	SCALE NTS	Drg. No. 2

Part A



Isometric Base
SCALE 1 : 3

All holes are drilled $\phi 5\text{mm}$
centre point 5mm from edge

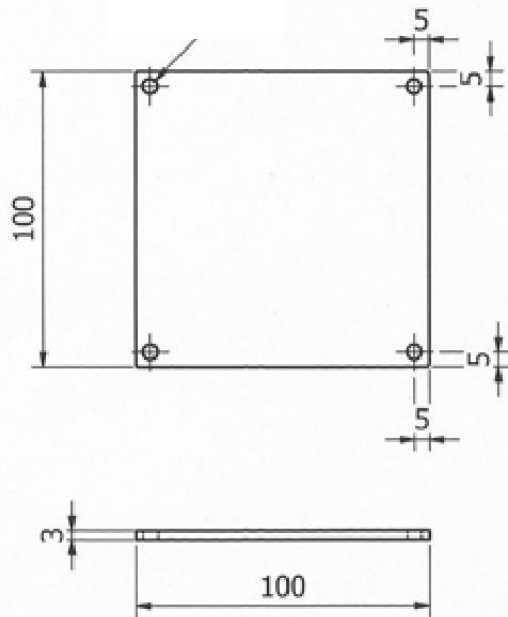

Part B

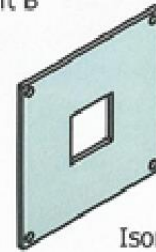

Isometric Lid
SCALE 1 : 3

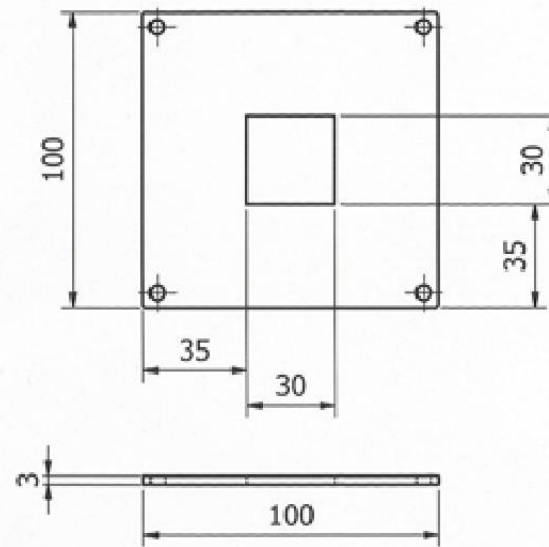

Cutting List					
Part	Material	Quantity	Length	Breadth	Thickness
A	steel	1	100	100	3
B	steel	1	100	100	3

2mm steel can be used if 3mm is unavailable

National 5 Practical Metalworking		
GARDEN LANTERN	SCALE NTS	Drg. No. 3

Part C

Option 1 square leg

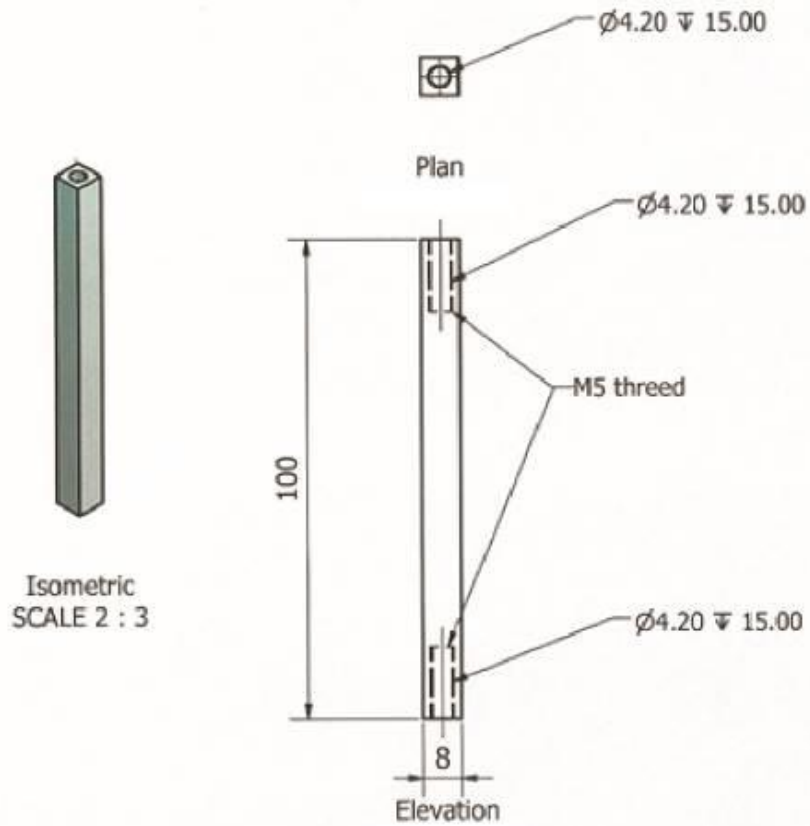

Cutting List					
Part	Material	Quantity	Length	Breadth	Thickness
C	Steel	4	100	8	8
D	steel	4	100	Ø 8	

Part D

Option 2 round leg

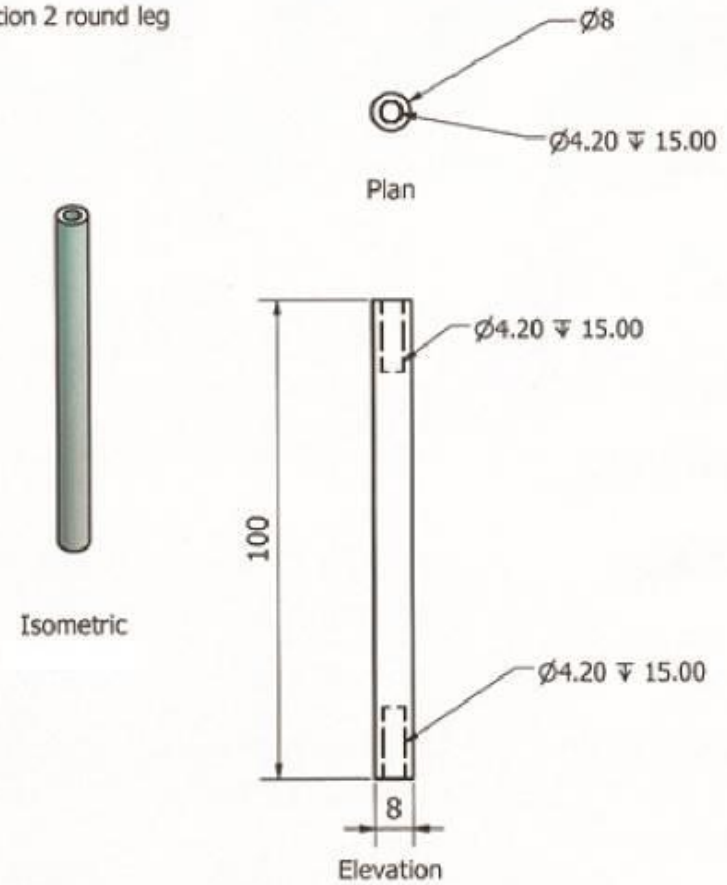

National 5 Practical Metalworking		
GARDEN LANTERN	SCALE NTS	Drg. No. 4

Part E

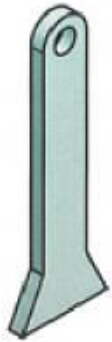

Handle Support

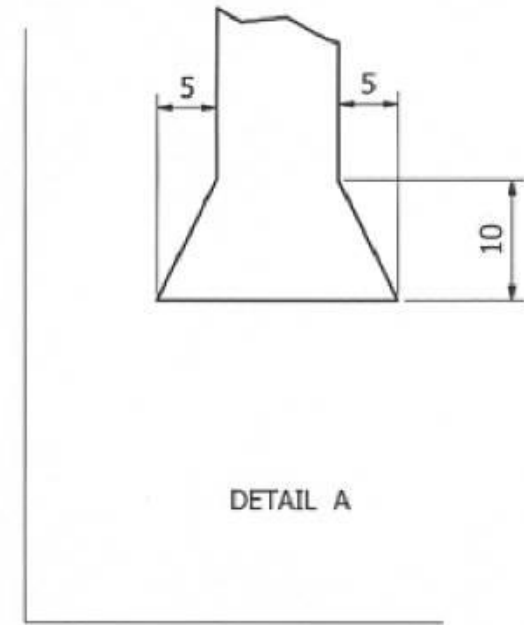
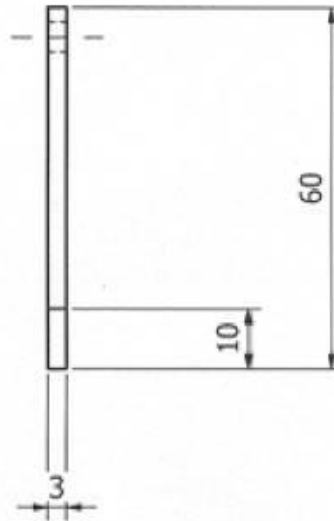
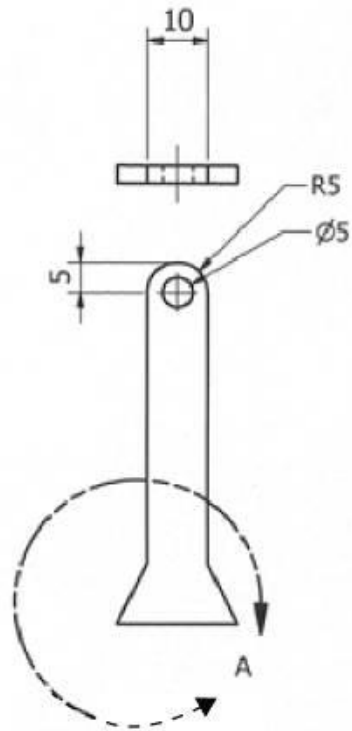

Cutting List					
Part	Material	Quantity	Length	Breadth	Thickness
E	Steel	2	60	20	3

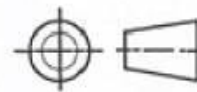

National 5 Practical Metalworking		
GARDEN LANTERN	SCALE NTS	Drg. No. 5

Part F

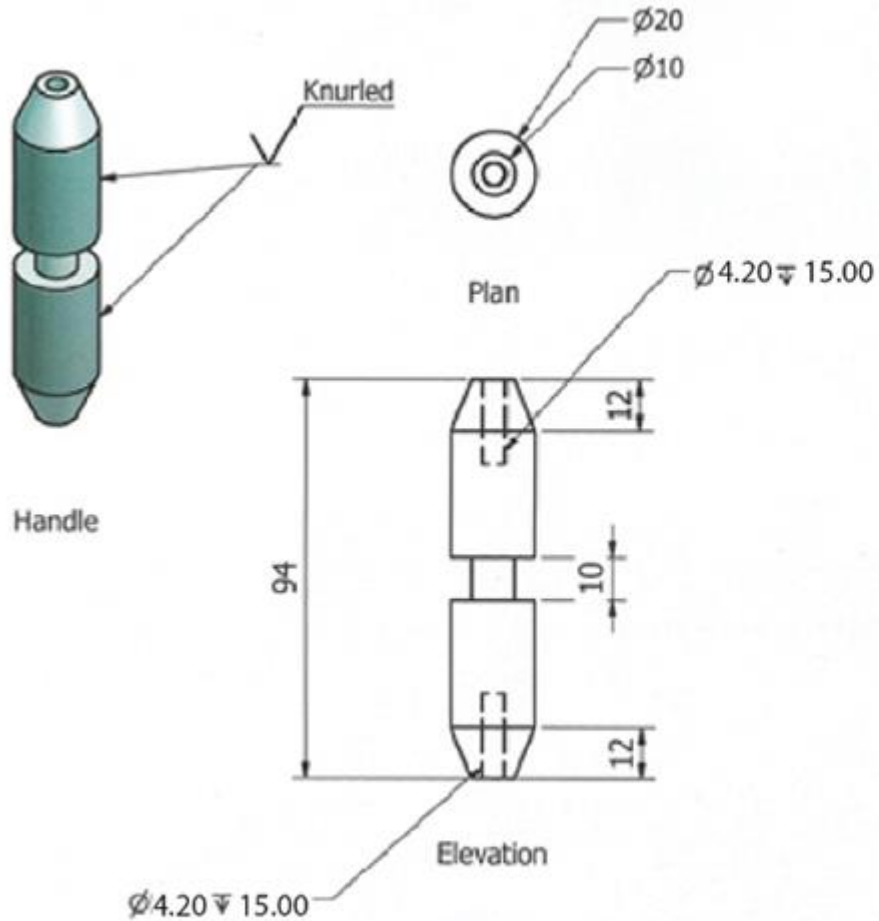

Handle

Part G

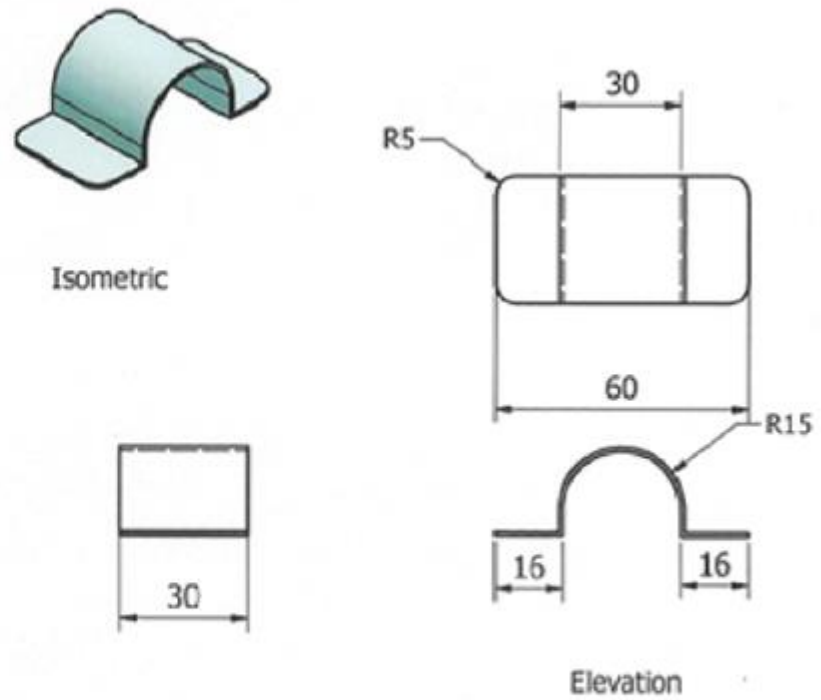

Cutting List					
Part	Material	Quantity	Length	Breadth	Thickness
F	Alluminium	1	94	∅ 20	
G	Steel	1	100	30	1

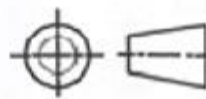

National 5 Practical Metalworking		
GARDEN LANTERN	SCALE NTS	Drq. No. 6

Part F



Isometric view

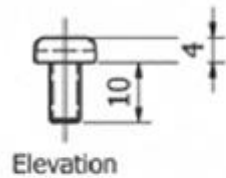
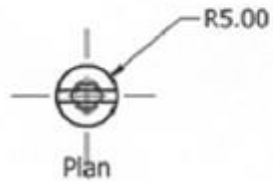

Part G



Isometric Foot

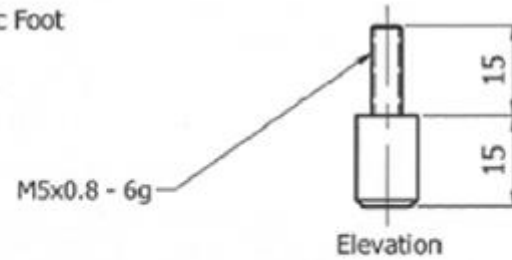
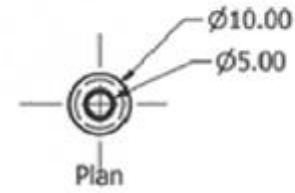

The M5 screw will be provided.
It is not to be manufactured.

Cutting List					
Part	Material	Quantity	Length	Breadth	Thickness
F	Steel	4	M5		
G	Steel	4	30	Ø 10	



National 5 Practical Metalworking		
GARDEN LANTERN	SCALE NTS	Drg. No. 7

Part H

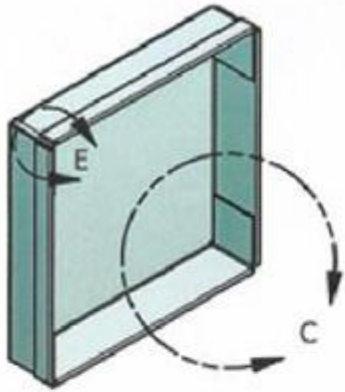

Candle Tray

Assembly of tray is spot welded or riveted

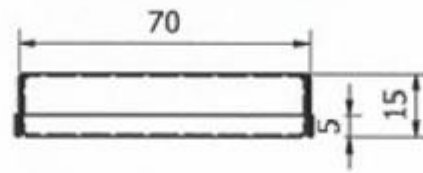

Plan

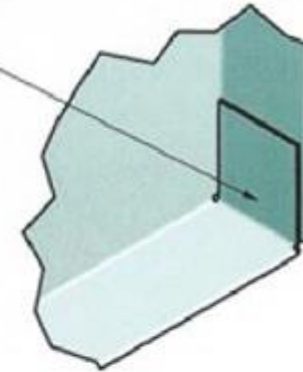

DETAIL C



DETAIL E



End Elevation



Elevation

Cutting List					
Part	Material	Quantity	Length	Breadth	Thickness
H	Steel	1	110	110	1

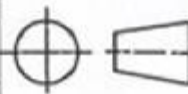

National 5 Practical Metalworking		
GARDEN LANTERN	SCALE NTS	Drg. No. 8

Sheet tray

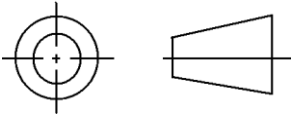
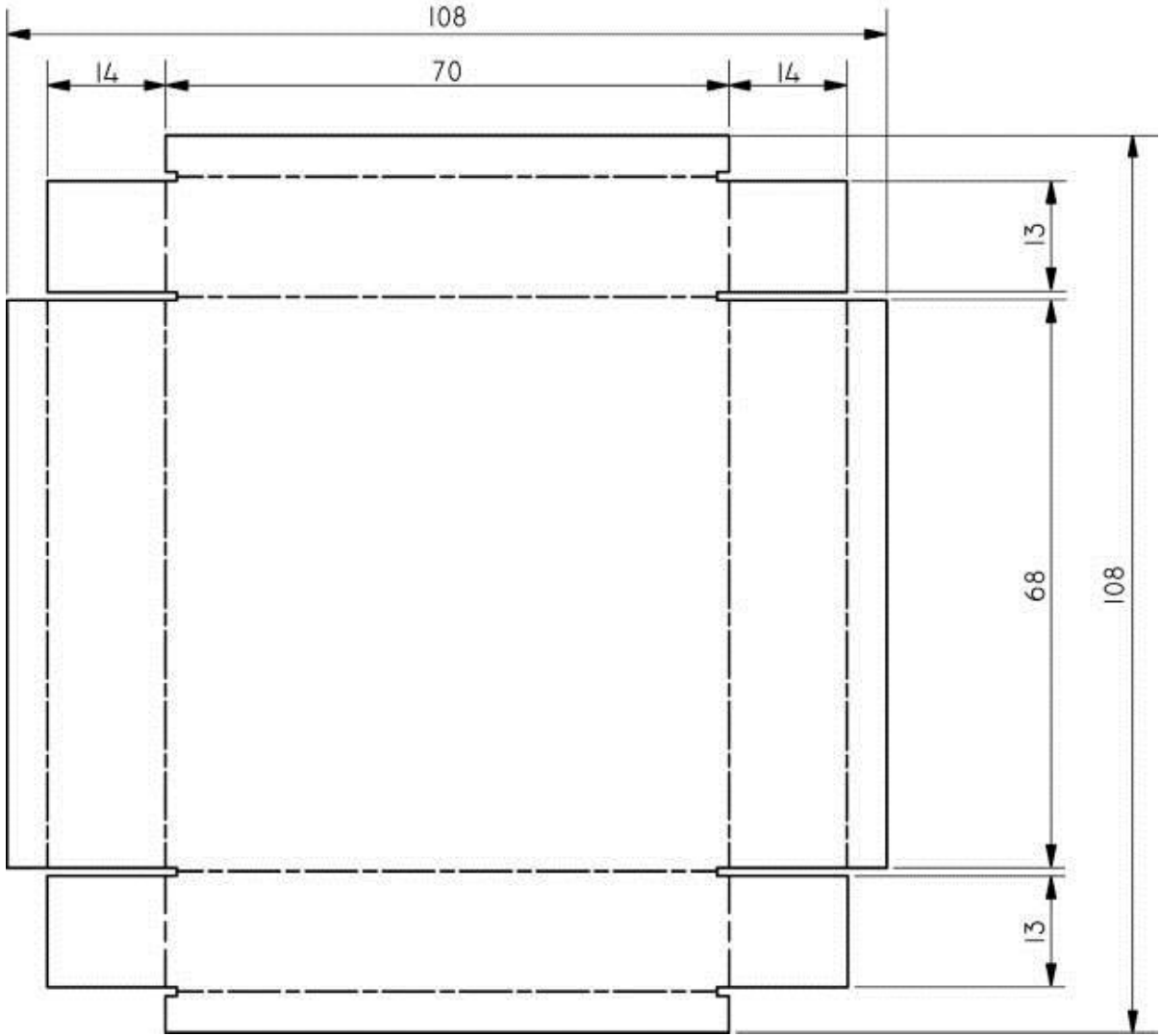

Administrative information

Published: November 2017 (version 1.0)

History of changes

Version	Description of change	Date

Security and confidentiality

This document can be used by practitioners in SQA approved centres for the assessment of National Courses and not for any other purpose.

This document may only be downloaded from SQA's designated secure website by authorised personnel.

Copyright

This document may be reproduced in whole or in part for assessment purposes provided that no profit is derived from reproduction and that, if reproduced in part, the source is acknowledged. If it needs to be reproduced for any purpose other than assessment, it is the centre's responsibility to obtain copyright clearance.

Re-use for alternative purposes without the necessary copyright clearance may constitute copyright infringement.

© Scottish Qualifications Authority 2012, 2017