

Engineering Science Data Booklet

Advanced Higher

For use in National Qualification Courses.

Publication date: January 2026

Published by Qualifications Scotland
The Optima Building, 58 Robertson Street, Glasgow G2 8DQ
Lowden, 24 Wester Shawfair, Dalkeith, Midlothian EH22 1FD

The information in this publication may be reproduced in support of Qualifications Scotland qualifications. If it is reproduced, Qualifications Scotland should be clearly acknowledged as the source. If it is to be used for any other purpose, then written permission must be obtained from Qualifications Scotland. It must not be reproduced for trade or commercial purposes.

Contents

Preface	3
Quantities, symbols and units	4
Decimal prefixes	5
Mathematical Relationships.	5
Energy and power formulae	6
Mechanisms	6
Pneumatic Systems	6
Structures	7
Properties of materials.	7
Bending of beams	8
Second moment of area (I) of common sections	9
Dimensions and properties of standard sections	10–12
Electrical and electronic formulae	13
Transistors	13
Typical operational amplifier circuits	14–18
Converter circuits	19
Ideal transformer	20

Preface

This data booklet is intended for use by candidates in examinations in Engineering Science at Advanced Higher. It may also be used as a reference for assignments at Advanced Higher. It is recommended that candidates should become familiar with the contents of the data booklet through use in undertaking Units of these Courses.

It should be noted that the range of data contained in the booklet has been limited to the concepts which may be assessed through written question papers. This range should be supplemented by other resource material as necessary during the course, eg by using data sheets. However, should any additional information (or data not included in this booklet) be required in an examination, such information will be included in the question paper.

Teachers/lecturers should note that all of the material contained in this booklet is likely to be examined at some time. With regard to tables of information, not every entry in a table will necessarily be involved in examination questions.

From the variety of data offered in this booklet, candidates will be expected to demonstrate the ability to select appropriate information or formulae.

Quantities, Symbols and Units

Quantity	Symbol	Unit	Abbreviation
distance	d,x	metre	m
height	h	metre	m
length	l	metre	m
diameter	d	metre	m
radius	r	metre	m
area	A	square metre	m ²
circumference	C	metre	m
time	t	second	s
speed, velocity	v	metre per second	ms ⁻¹
mass	m	kilogram	kg
force	F	newton	N
gravitational acceleration	g	metre per second per second	ms ⁻²
work done	E _w	joule	J
energy	E	joule	J
power	P	watt	W
torque	T	newton metre	Nm
efficiency	η	-	-
pressure	P	newton per square metre (pascal)	Nm ⁻² (Pa)
temperature	T	kelvin, celsius	K, °C
specific heat capacity	c	joule per kilogram per degree kelvin	Jkg ⁻¹ K ⁻¹
voltage, potential difference	V	volt	V
current	I	ampere (amp)	A
resistance	R	ohm	Ω
frequency	f	hertz	Hz
rotational speed	n	revolutions per minute	revs min ⁻¹
		revolutions per second	revs sec ⁻¹
stress	σ	newton per square metre (pascal)	Nm ⁻² (Pa)
strain	ε	-	-

Decimal Prefixes

Prefix	Symbol	Multiplying factor
peta	P	10^{15}
tera	T	10^{12}
giga	G	10^9
mega	M	10^6
kilo	k	10^3
milli	m	10^{-3}
micro	μ	10^{-6}
nano	n	10^{-9}
pico	p	10^{-12}

Mathematical Relationships

Quadratic Formula

$$ax^2 + bx + c = 0$$

$$x = \frac{-b \pm \sqrt{b^2 - 4ac}}{2a}$$

Differentiation

Conditions for a maximum value of a function $y(x)$

$$\frac{dy}{dx} = 0, \quad \frac{d^2y}{dx^2} < 0$$

Relationships

Energy and power

Potential energy	$E_p = mgh$	$g = 9.8 \text{ ms}^{-2}$ (to 2 significant figures)
Kinetic energy	$E_k = \frac{1}{2}mv^2$	
Heat energy	$E_h = cm\Delta T$	$c_{\text{water}} = 4180 \text{ Jkg}^{-1}\text{K}^{-1}$
Electrical energy	$E_e = VIt$	
Work done	$E_w = Fd$	
Power	$P = \frac{E}{t}$	
Electrical power	$P = VI = \frac{V^2}{R} = I^2R$	
Mechanical power	$P = Fv$	$P = 2\pi nT$ (n = number of revs per second)
Efficiency	$\eta = \frac{\text{Energy}_{\text{out}}}{\text{Energy}_{\text{in}}} = \frac{\text{Power}_{\text{out}}}{\text{Power}_{\text{in}}}$	

Mechanisms

Velocity ratio	$VR = \frac{\text{speed of input}}{\text{speed of output}}$		
	Input speed x input size = output speed x output size		
Torque	$T = Fr$		
Circumference of circle	$C = \pi d$		
Moment of force	$M = Fx$	(x is perpendicular distance)	
Principle of moments	$\Sigma M = 0$		
	$\Sigma \text{ clockwise moments} = \Sigma \text{ anti-clockwise moments}$		
Conditions of equilibrium	$\Sigma F_h = 0$	$\Sigma F_v = 0$	$\Sigma M = 0$

Pneumatic Systems

Pressure, force and area	$P = \frac{F}{A}$	
Area of circle	$A = \pi r^2$	$A = \frac{\pi d^2}{4}$

Structures

Stress $\sigma = \frac{F}{A}$

Strain $\epsilon = \frac{\Delta l}{l}$

Young's Modulus $E = \frac{\sigma}{\epsilon}$

Factor of Safety $= \frac{\text{ultimate load}}{\text{safe working load}} = \frac{\text{ultimate stress}}{\text{safe working stress}}$

General Bending Equation $\frac{M}{I} = \frac{\sigma}{y} = \frac{E}{R}$

Shear Force $F_s = \frac{dM}{dx}$

Properties of materials

Material	Young's Modulus E kNmm ⁻²	Yield stress σ_y Nmm ⁻²	Ultimate tensile stress Nmm ⁻²	Ultimate compressive stress Nmm ⁻²
Mild steel	196	220	430	430
Stainless steels	190-200	286-500	760-1280	460-540
Low-alloy steels	200-207	500-1980	680-2400	680-2400
Cast iron	120	-	120-160	600-900
Aluminium alloy	70	250	300	300
Titanium alloy	110	950	1000	1000
Nickel alloys	130-234	200-1600	400-2000	400-2000
Concrete	-	-	-	60
Concrete (steel reinforced)	45-50	-	-	100
Concrete (post stressed)	-	-	-	100
Plastic, ABS polycarbonate	2.6	55	60	85
Plastic, polypropylene	0.9	19-36	33-36	70
Wood, parallel to grain	9-16	-	55-100	6-16
Wood, perpendicular to grain	0.6-1.0	-	-	2-6

Bending of Beams

All beams of length L , second moment of area I , and Young's modulus E .
Point C is located at mid-span.

ω = load per unit length (uniformly distributed load)

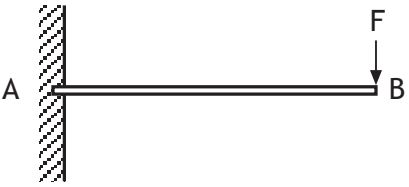
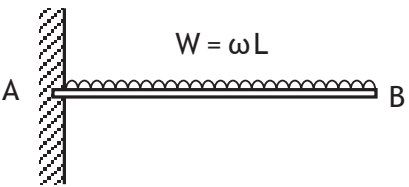
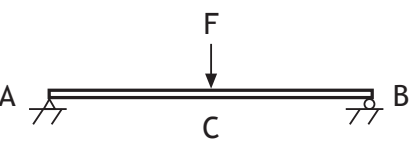
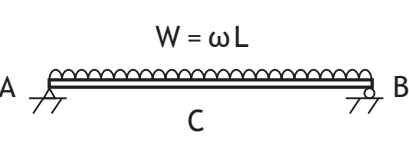
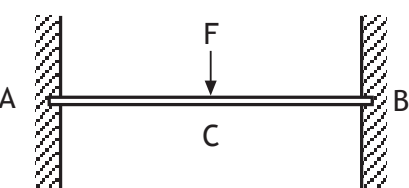
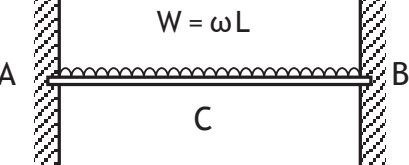
Configuration	Maximum Bending Moment	Maximum Deflection
	$= FL$ at A	$= \frac{FL^3}{3EI}$ at B
	$= \frac{\omega L^2}{2}$ at A	$= \frac{\omega L^4}{8EI}$ at B
	$= \frac{FL}{4}$ at C	$= \frac{FL^3}{48EI}$ at C
	$= \frac{\omega L^2}{8}$ at C	$= \frac{5\omega L^4}{384EI}$ at C
	$= \frac{FL}{8}$ at C $= -\frac{FL}{8}$ at A, B	$= \frac{FL^3}{192EI}$ at C
	$= \frac{\omega L^2}{24}$ at C $= -\frac{\omega L^2}{12}$ at A, B	$= \frac{\omega L^4}{384EI}$ at C

Second Moment of Area (I) of Common Sections

Rectangular

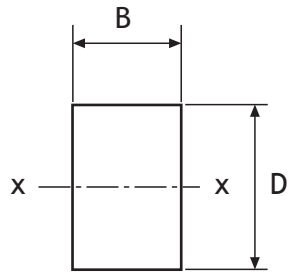

$$I_{xx} = \frac{BD^3}{12}$$

Circular

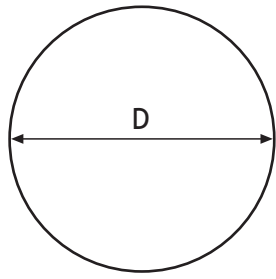

$$I = \frac{\pi D^4}{64}$$

Dimensions and Properties of Standard Sections

Dimensions and Properties of Square Hollow Sections

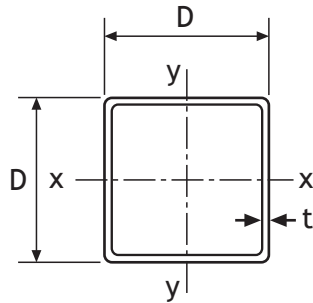

Designation		Second moment of area ($\times 10^4 \text{ mm}^4$)
Size $D \times D$ (mm)	Thickness t (mm)	
20 × 20	2.0	0.76
	2.6	0.88
30 × 30	2.6	3.49
	3.2	4.00
40 × 40	2.6	8.94
	3.2	10.40
	4.0	12.10
50 × 50	3.2	21.60
	4.0	25.50
	5.0	29.60
60 × 60	3.2	38.70
	4.0	46.10
	5.0	54.40

Dimensions and Properties of Rectangular Hollow Sections

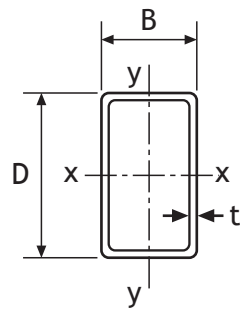

Designation		Second moment of area ($\times 10^4 \text{ mm}^4$)	
Size $D \times B$ (mm)	Thickness t (mm)	Axis x-x	Axis y-y
50 × 30	2.6	12.40	5.45
	3.2	14.50	6.31
60 × 40	3.2	28.30	14.80
	4.0	33.60	17.30
80 × 40	3.2	58.10	19.10
	4.0	69.60	22.60
90 × 50	3.6	99.80	39.10
	5.0	130.00	50.00
100 × 50	3.2	117.00	39.10
	4.0	142.00	46.70
	5.0	170.00	55.10

Dimensions and Properties of Joists

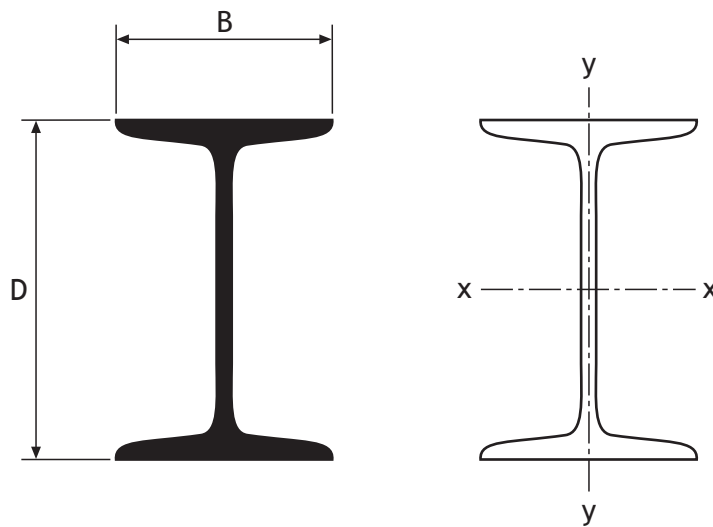

Depth of section D (mm)	Breadth of section B (mm)	Second moment of area ($\times 10^4 \text{ mm}^4$)	
		Axis x-x	Axis y-y
127	114	944.80	235.40
127	76	569.40	60.35
114	114	735.40	223.10
102	102	486.10	154.40
102	64	217.60	25.30
102	44	152.30	7.91
89	89	306.70	101.10
76	80	171.90	60.77
76	76	158.60	52.03

Electrical and electronic

Ohm's Law

$$V = IR$$

Resistors in series

$$R_t = R_1 + R_2 + R_3 + \dots$$

Resistors in parallel

$$\frac{1}{R_t} = \frac{1}{R_1} + \frac{1}{R_2} + \frac{1}{R_3} + \dots$$

2 resistors in parallel

$$R_t = \frac{R_1 R_2}{(R_1 + R_2)}$$

Kirchhoff's 1st law

$$\Sigma I = 0 \text{ (algebraic sum of currents at a node is zero)}$$

Kirchhoff's 2nd law

$$\Sigma E = \Sigma IR$$

(algebraic sum of supply voltages = sum of voltage-drops, in a closed loop)

Voltage Divider

$$\frac{V_1}{V_2} = \frac{R_1}{R_2}$$

Electrical power

$$P = VI = \frac{V^2}{R} = I^2 R$$

Transistors

Bi-polar transistor gain

$$h_{FE} = I_c / I_b$$

MOSFET transconductance

$$g_m = \Delta I_d / \Delta V_{gs}$$

Typical operational amplifier circuits

V_o = output voltage

V_i = input voltage

V_{cc} = supply voltage

R_f = feedback resistance

R_i = input resistance

A_v = gain = $\frac{\text{output voltage}}{\text{input voltage}}$

Inverting

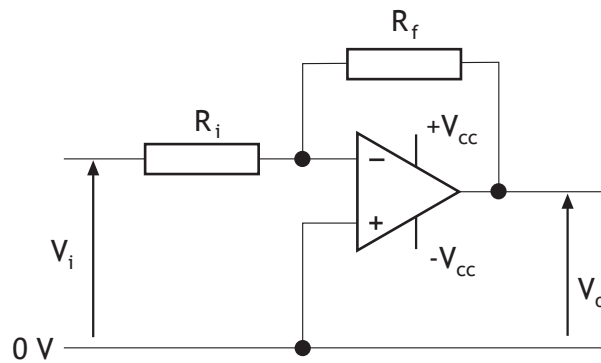

$$A_v = \frac{V_o}{V_i}$$

$$A_v = -\frac{R_f}{R_i}$$

$$V_o = -\frac{R_f}{R_i} V_i$$

Non-inverting

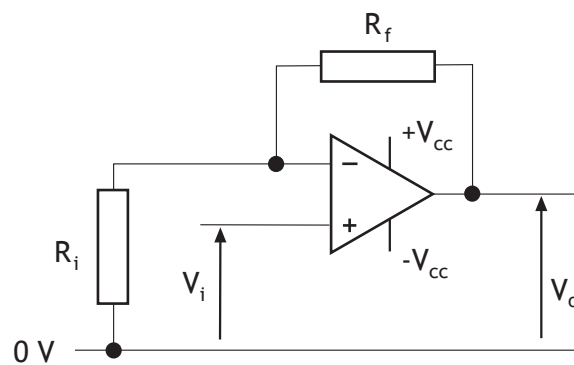

$$A_v = \frac{V_o}{V_i}$$

$$A_v = 1 + \frac{R_f}{R_i}$$

$$V_o = \left(1 + \frac{R_f}{R_i}\right) V_i$$

Comparator

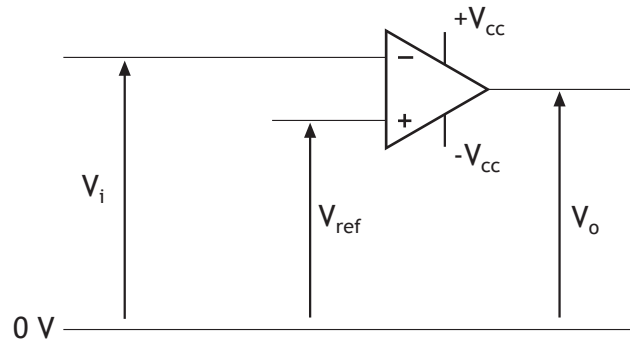

If $V_i < V_{ref}$, then V_o saturates positively

If $V_i > V_{ref}$, then V_o saturates negatively

Difference Amplifier

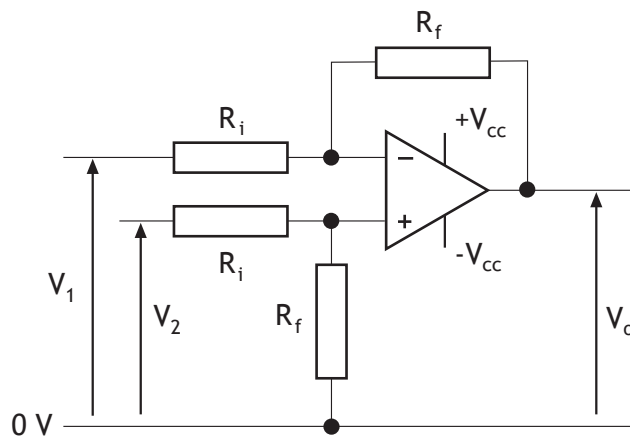

$$A_v = \frac{V_o}{(V_2 - V_1)}$$

$$A_v = \frac{R_f}{R_i}$$

$$V_o = \frac{R_f}{R_i}(V_2 - V_1)$$

Summing Amplifier

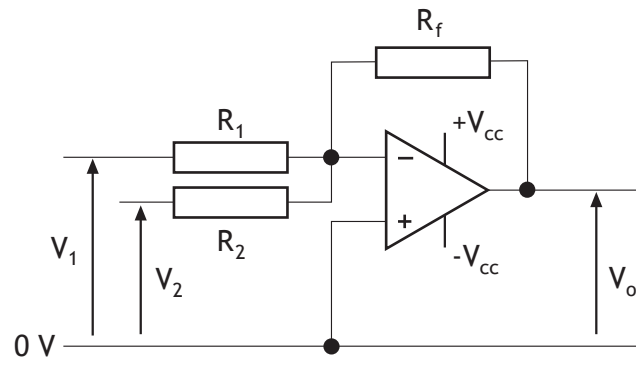

$$A_{v1} = - \frac{R_f}{R_1} \quad A_{v2} = - \frac{R_f}{R_2} \quad A_{vn} = - \frac{R_f}{R_n}$$

$$V_o = (A_{v1} V_1) + (A_{v2} V_2) + \dots$$

$$V_o = - R_f \left(\frac{V_1}{R_1} + \frac{V_2}{R_2} + \dots \right)$$

Voltage Follower

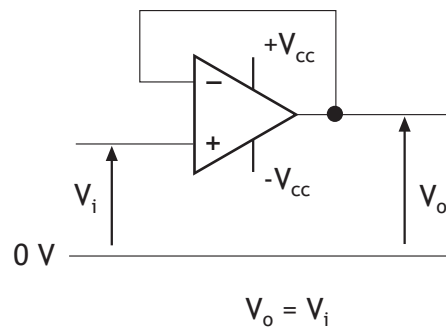

Integrator

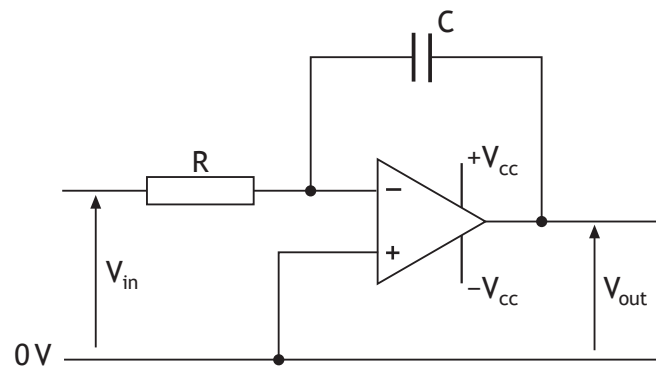

$$\Delta V_{\text{out}} = -\frac{1}{RC} \int V_{\text{in}} dt$$

Schmitt Trigger

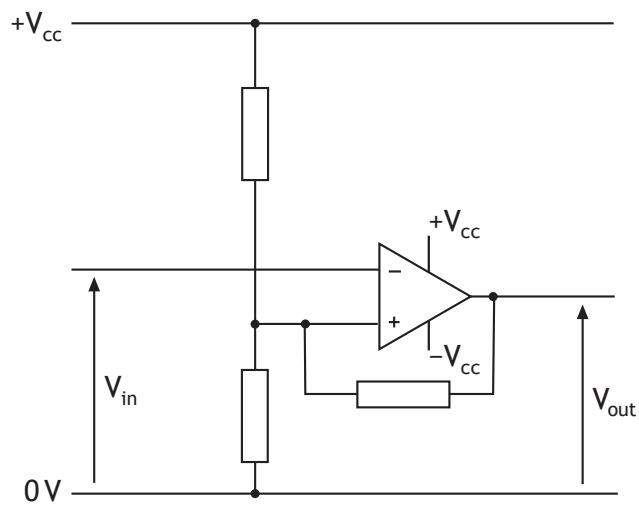

Wien Bridge Oscillator

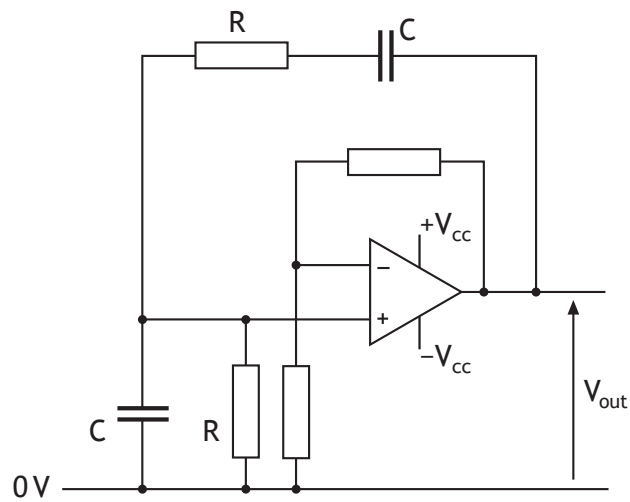

$$\text{Frequency: } f = \frac{1}{2\pi RC}$$

555 Timer (astable mode)

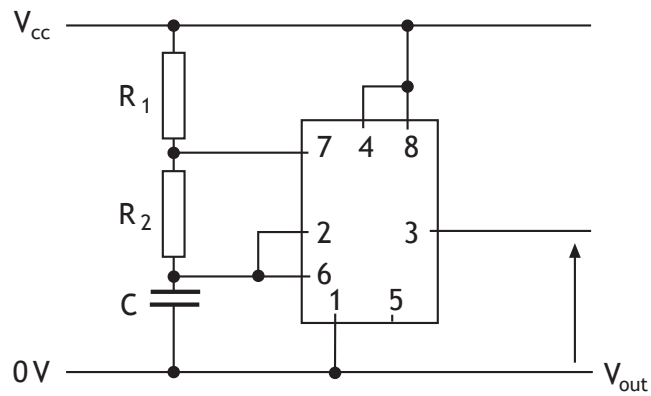

Mark: $T_1 = 0.7(R_1 + R_2)C$

Space: $T_2 = 0.7 R_2 C$

Frequency: $f = \frac{1.44}{(R_1 + 2R_2)C}$

4-bit D-A converter

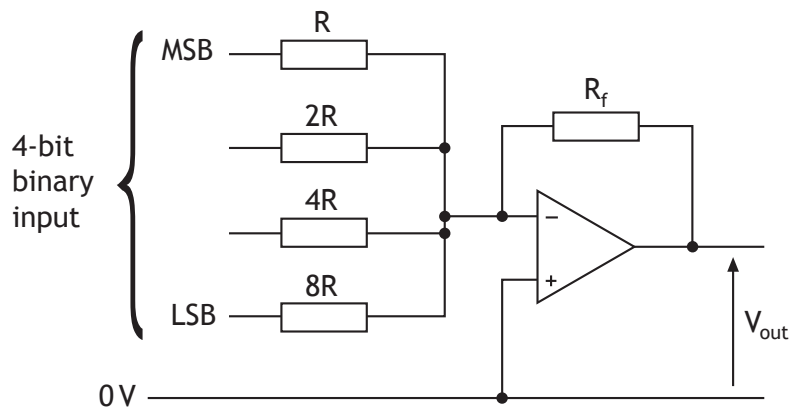

A-D converter

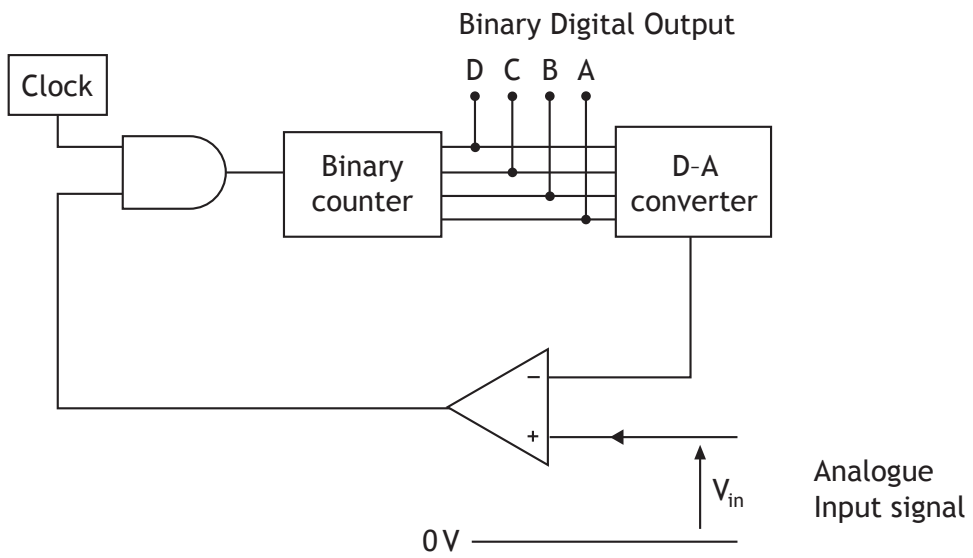

Ideal Transformer Relationships

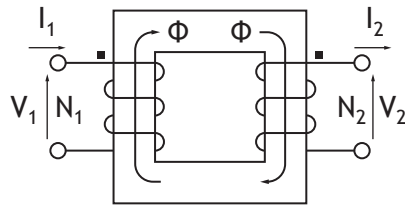

$\Phi = \text{constant}$

$$\frac{V_2}{V_1} = \frac{I_1}{I_2} = \frac{N_2}{N_1}$$

[END OF DATA BOOKLET]

Published: January 2026

Change since last published:

Publication code removed