



2013 Graphic Communication

Standard Grade Credit

Finalised Marking Instructions

© Scottish Qualifications Authority 2013

The information in this publication may be reproduced to support SQA qualifications only on a non-commercial basis. If it is to be used for any other purposes written permission must be obtained from SQA's NQ Assessment team.

Where the publication includes materials from sources other than SQA (secondary copyright), this material should only be reproduced for the purposes of examination or assessment. If it needs to be reproduced for any other purpose it is the centre's responsibility to obtain the necessary copyright clearance. SQA's NQ Assessment team may be able to direct you to the secondary sources.

These Marking Instructions have been prepared by Examination Teams for use by SQA Appointed Markers when marking External Course Assessments. This publication must not be reproduced for commercial or trade purposes.

Part One: General Marking Principles for Graphic Communication Standard Grade Credit

This information is provided to help you understand the general principles you must apply when marking candidate responses to questions in this Paper. These principles must be read in conjunction with the specific Marking Instructions for each question.

- (a)** Marks for each candidate response must always be assigned in line with these general marking principles and the specific Marking Instructions for the relevant question. If a specific candidate response does not seem to be covered by either the principles or detailed Marking Instructions, and you are uncertain how to assess it, you must seek guidance from your Team Leader/Principal Assessor.
- (b)** Marking should always be positive ie, marks should be awarded for what is correct and not deducted for errors or omissions.

GENERAL MARKING ADVICE: Graphic Communication Standard Grade Credit

The marking schemes are written to assist in determining the “minimal acceptable answer” rather than listing every possible correct and incorrect answer. The following notes are offered to support Markers in making judgements on candidates’ evidence, and apply to marking both end of unit assessments and course assessments.

Part Two: Marking Instructions for each Question

- | | | |
|----------------|---|-------------|
| 1 a | <ol style="list-style-type: none">1. Ability to create a library of commonly used parts/Ease of storage/Greater accuracy/more accurate2. Easier to edit drawings/Creation of new design from existing/Standardisation/layering3. Easier to send drawing to other places using <u>e-mail</u> | KI 3 |
| 1 b | <ol style="list-style-type: none">1. Possibility of data loss/Set-up costs/ Cost of hardware/cost of software2. Possibility of system failure/crash Data security/cost of training3. Hacking/Viruses etc. | KI 3 |
| 1 c | Device 1 Scanner/Digital camera
Device 2 Digitiser | KI 2 |
| 1 d i | DTP | KI 1 |
| 1 d ii | CAD/3D Modelling | KI 1 |
| 1 d iii | Illustration/Paint/3D modelling | KI 1 |

Total KI 11

2	a	View 1 Exploded Isometric/Exploded View 2 Sectional Isometric/Section/Sectioned	KI 2	
2	b	Purpose of View 1 To show how the parts fit together Purpose of View 2 To show details that would not be seen in the ordinary isometric. To be able to see details of the inside of the component.	KI 2	also, to show parts more clearly
2	c	Drawing A <u>Orthographic</u> Views	KI 1	
2	d	Answer 1 Drum Answer 2 Flatbed	KI 2	
2	e	i Planometric	KI 1	
		ii 45°	KI 1	
2	f	The drawing is five times the size of the object being drawn	KI 1	

Total KI 10

- | | | | |
|----------|----------|---|-------------|
| 3 | a | The work being done by the designers in the different countries could be sent to each other via the internet/Faster to communicate design changes or improvements to each other/Design work will be completed faster so lead time will be reduced | KI 1 |
| 3 | b | Ease of storage and transportation | KI 1 |
| 3 | c | Answer: Can not be handled (1)

Answer: Need to have the correct software and can only be viewed on a computer (1) | KI 2 |
| 3 | d | In case any of the day's work is lost/to protect the company from data loss | KI 1 |
| 3 | e | 1. Wire frame

2. Solid

3. Surface Rendered/Surface/Surface model | KI 3 |
| 3 | f | Animation is watched, simulations can be interacted with/You can affect the outcome of a simulation. You can only watch an animation. | KI 1 |
| 3 | g | They could use an animation as part of a sales advert/They could use an animation to demonstrate or show features/They could use an animation to give instructional information about the product. Advertising. | KI 1 |

Total KI 10

4 a **Answer 1** 3 **KI 2**
Answer 2 4

4 b Isometric **KI 1**

4 c Pictorial **KI 1**

4 d **Answer 1** The size of the paper being used **KI 2**
Answer 2 The size of the object being drawn/The amount of detail needing to be shown

4 e That everyone that reads the drawing will be able to understand conventions. Makes understanding the drawing easier as everyone uses the same conventions. **KI 1**

4 f **KI 2**

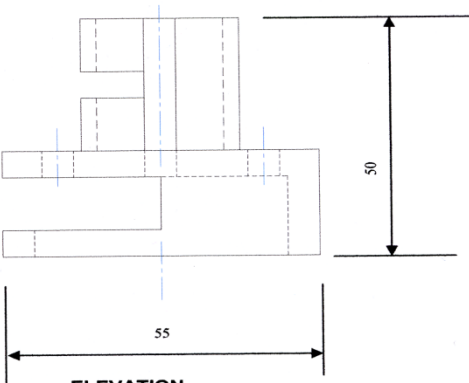

ELEVATION

Total KI 9

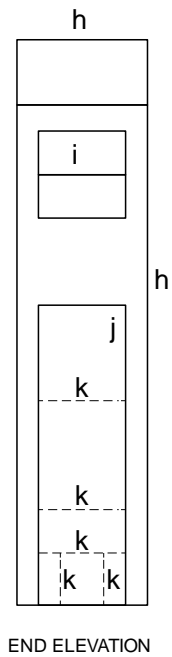
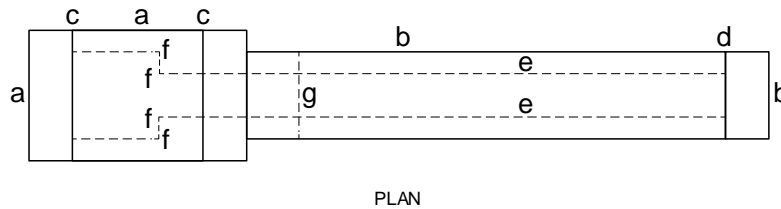

**Question 5
Plan**

- (a) length and width 1
- (b) length, width & position 1
- (c) lines (both) 1
- (d) line 1
- (e) hidden lines (both) 1
- (f) hidden line (all four) 1
- (g) hidden line 1

DA 7

End Elevation

- (h) height and width 1
- (i) height, width & position 1
- (j) height, width & position 1
- (k) hidden lines (5 for 2, 3 for 1) 2

DA 5

Total (DA 12)

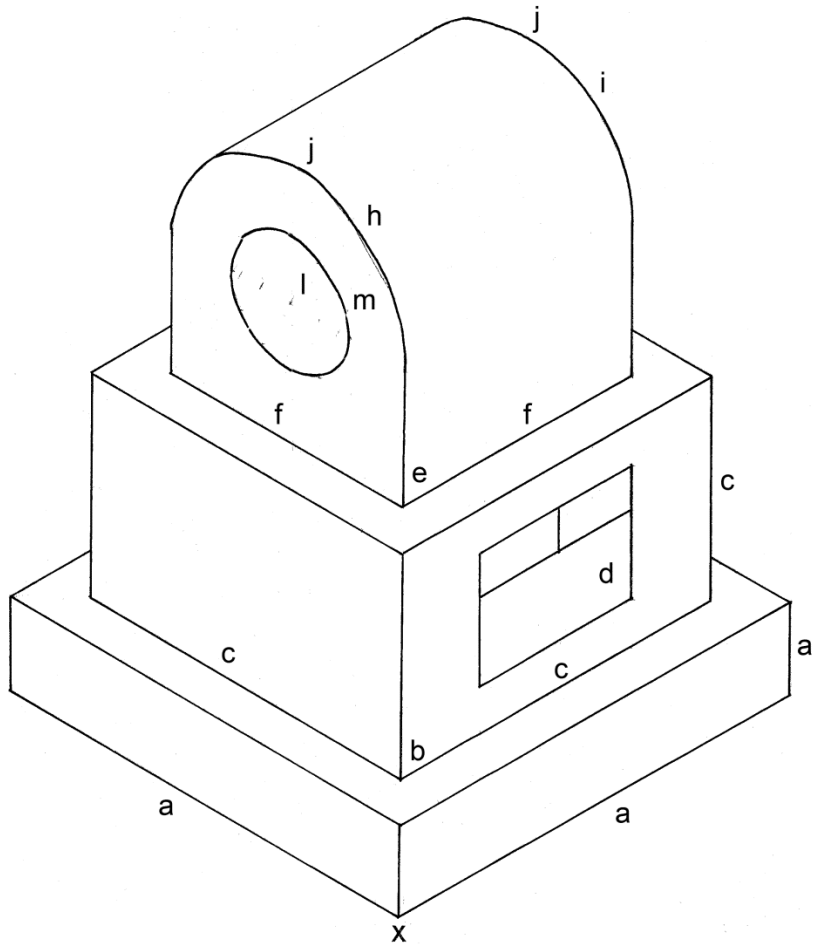

Question 6

Isometric

- | | | |
|-----|---|----------|
| (a) | crate length, width & height (3 for 2, 2 for 1) | 2 |
| (b) | Position | 1 |
| (c) | crate length, width + height (3 for 2, 2 for 1) | 2 |
| (d) | window size and position | 1 |
| (e) | position | 1 |
| (f) | length and width | 1 |
| (g) | construction for isometric semi-circle/ circle | 1 |
| (h) | establish 7 points on curve (7 for 2, 5 for 1) | 2 |
| (i) | establish back curve points and tangent line | 1 |
| (j) | smooth curves (2 from 3) | 1 |
| (l) | establish 12 points on circle (12 for 2, 8 for 1) | 2 |

DA 15

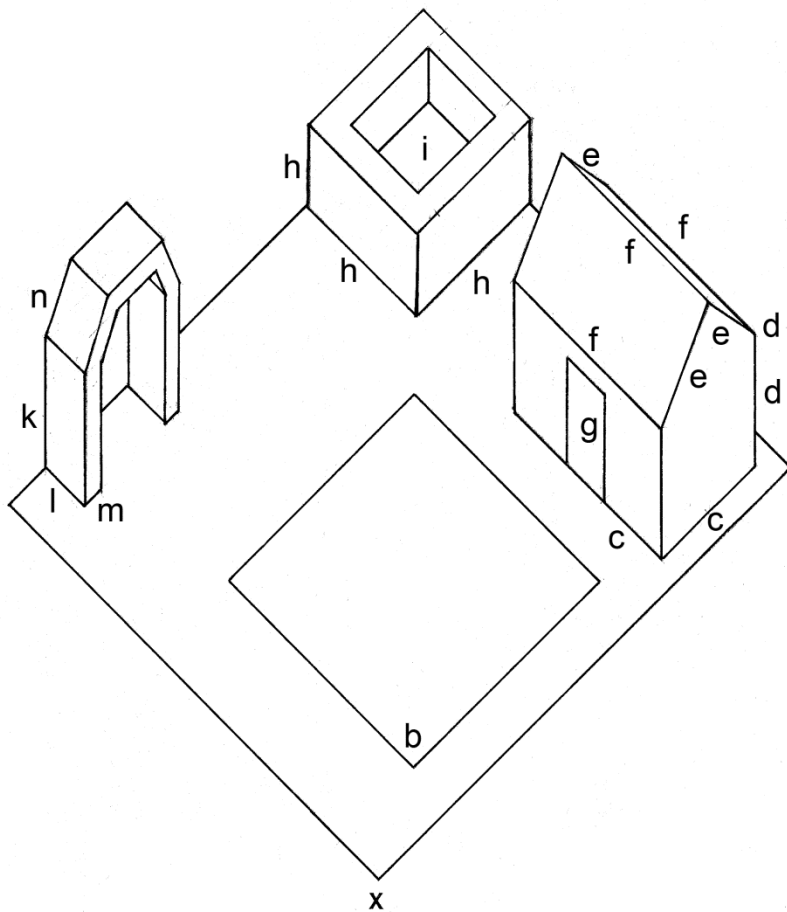

Question 7

Planometric

- (a) garden length and width 1
- (b) lawn length, width and position 1
- (c) length and width of shed 1
- (d) correct heights (both) 1
- (e) diagonal lines to apex shown (all four) 1
- (f) 45° roof lines shown (all three) 1
- (g) door size and position 1
- (h) length, width and height of flower bed 2
(3 for 2, 2 for 1)
- (i) flower bed recess shown 1
- (k) six vertical lines (5 or 6 for 1) 1
- (l) six 45° lines (5 or 6 for 1) 1
- (m) six 45° lines (4 or 5 for 1) 1
- (n) angled lines (4 or 5 for 1) 1

DA 14

Question 8

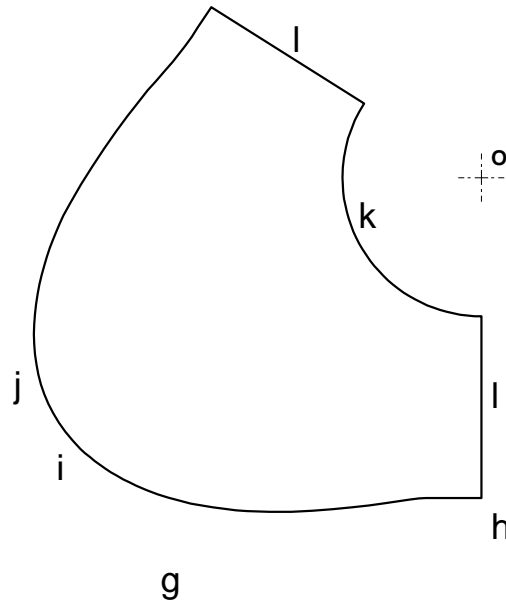
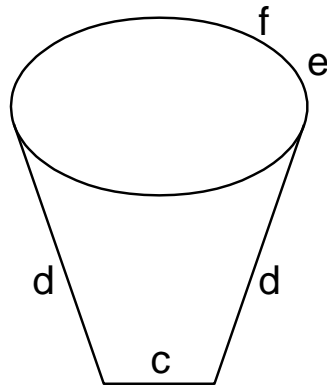
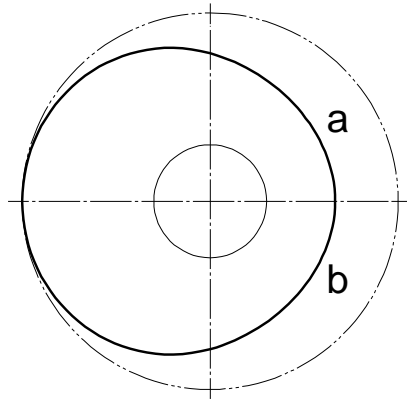

Plan

- (a) establish 12 points (12 for 2, 8 for 1) **2**
- (b) smooth curve **1**

End Elevation

- (c) horizontal line **1**
- (d) diagonal lines (both) **1**
- (e) establish 12 points (12 for 2, 8 for 1) **2**
- (f) smooth curve **1**

Surface development

- (g) correct circumference **1**
- (h) true length used at all points **1**
- (i) 7 key heights established (7 for 2, 5 for 1) **2**
- (j) smooth curve **1**
- (k) top curve **1**
- (l) lines shown **1**

DA 15

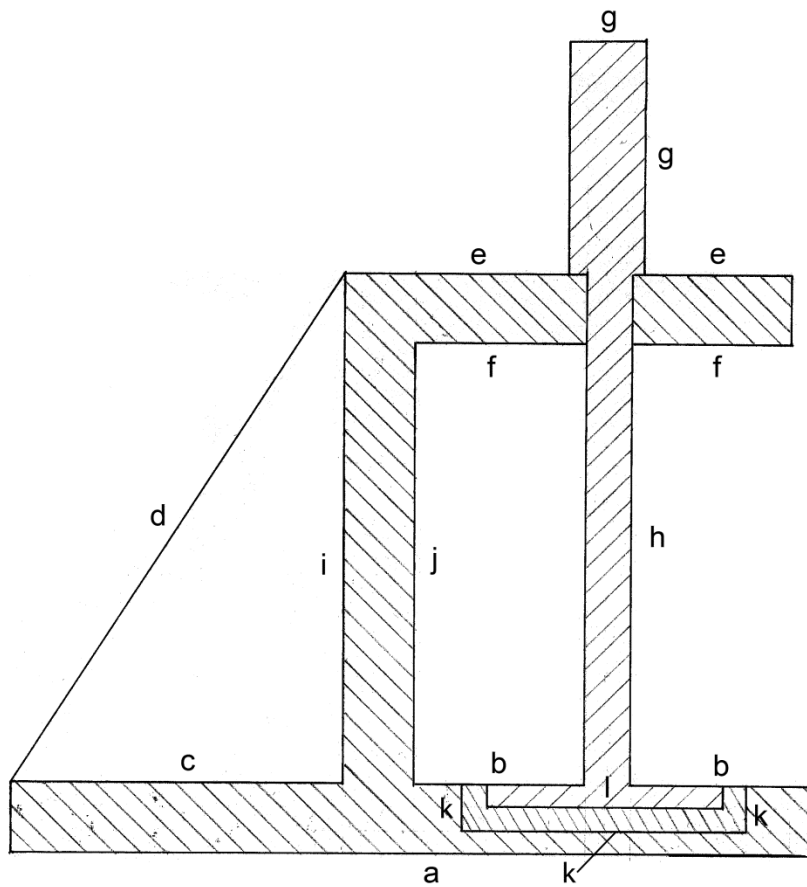

Question 9
Sectional

- | | | |
|-----|-----------------------------|---|
| (a) | length | 1 |
| (b) | length | 1 |
| (c) | length | 1 |
| (d) | diagonal line | 1 |
| (e) | length | 1 |
| (f) | length | 1 |
| (g) | diameter and height | 1 |
| (h) | diameter and height | 1 |
| (i) | height | 1 |
| (j) | height | 1 |
| (k) | stopper diameter and height | 1 |
| (l) | stopper thickness shown | 1 |
| (m) | hatching shown | 1 |
| (n) | hatching to correct BS | 1 |

Total **14**

[END OF MARKING INSTRUCTIONS]