



National
Qualifications
2018

2018 Engineering Science

Higher

Finalised Marking Instructions

© Scottish Qualifications Authority 2018

The information in this publication may be reproduced to support SQA qualifications only on a non-commercial basis. If it is reproduced, SQA should be clearly acknowledged as the source. If it is to be used for any other purpose, written permission must be obtained from permissions@sqa.org.uk.

Where the publication includes materials from sources other than SQA (secondary copyright), this material should only be reproduced for the purposes of examination or assessment. If it needs to be reproduced for any other purpose it is the centre's responsibility to obtain the necessary copyright clearance. SQA's NQ Assessment team may be able to direct you to the secondary sources.

These marking instructions have been prepared by examination teams for use by SQA appointed markers when marking external course assessments. This publication must not be reproduced for commercial or trade purposes.



General marking principles for Higher Engineering Science

This information is provided to help you understand the general principles you must apply when marking candidate responses to questions in this Paper. These principles must be read in conjunction with the detailed marking instructions, which identify the key features required in candidate responses.

- (a) Marks for each candidate response must always be assigned in line with these general marking principles and the detailed marking instructions for this assessment.
- (b) Marking should always be positive, ie marks should be awarded for what is correct and not deducted for errors or omissions.
- (c) If a specific candidate response does not seem to be covered by either the principles or detailed marking instructions, and you are uncertain how to assess it, you must seek guidance from your team leader.
- (d) Where a candidate makes an error at an early stage in a multi-stage calculation, credit should normally be given for correct follow-on working in subsequent stages, unless the error significantly reduces the complexity of the remaining stages. The same principle should be applied in questions which require several stages of non-mathematical reasoning.
- (e) All units of measurement will be presented in a consistent way, using negative indices where required (eg ms^{-1}). Candidates may respond using this format, or solidus format (m/s), or words (metres per second), or any combination of these (eg metres/second).
- (f) Answers to numerical questions should normally be rounded to an appropriate number of significant figures. However, the mark can be awarded for answers which have up to two figures more or one figure less than the expected answer.
- (g) Unless a numerical question specifically requires evidence of working to be shown, full marks should be awarded for a correct final answer (including unit) on its own.
- (h) A mark can be awarded when a candidate writes down the relevant formula **and** substitutes correct values into the formula. No mark should be awarded for simply writing down a formula, without any values.
- (i) Credit should be given where a labelled diagram or sketch conveys clearly and correctly the response required by the question.
- (j) Marks should be awarded regardless of spelling as long as the meaning is unambiguous.
- (k) Candidates may answer programming questions in any appropriate programming language. Marks should be awarded, regardless of minor syntax errors, as long as the intention of the coding is clear.
- (l) Where a question asks the candidate to “explain”, marks should only be awarded where the candidate goes beyond a description, for example by giving a reason, or relating cause to effect, or providing a relationship between two aspects.
- (m) Where separate space is provided for rough working and a final answer, marks should normally only be awarded for the final answer, and all rough working ignored.

Marking instructions for each question

Question			Expected response	Max mark	Additional guidance
1.	(a)	(i)	$E = 150/0.0015$ $E = 100 \text{ kNmm}^{-2}$	2	1 mark for selecting a suitable points on the graph (stress/strain) 1 mark for correct answer with unit Accept 100000 Nmm^{-2}
		(ii)	Straight line to have a steeper gradient than trace already shown on graph	1	There must be a clear attempt at a straight line in the initial stage of the graph from the origin
	(b)		$E_s = 0.5 \times 11.8 \times 0.225$ $E_s = 1.3275$ $E_s = 1.3 \text{ J (2 sf)}$	1	1 mark for final answer and unit
2.			$\Sigma F_v = 0$ $0 = -R_v + 153\sin 71 - 62\sin 45$ $R_v = 144.7 - 43.8 = 100.8237\text{N}$ $\Sigma F_H = 0$ $0 = 153\cos 71 + 62\cos 45 - R_H$ $R_H = 93.6525\text{N}$ $R = \sqrt{100.8237^2 + 93.6525^2}$ $= 137.6089$ $= 140 \text{ N (2 sf)}$	3	1 mark R_v value (no unit required) 1 mark R_H value (no unit required) 1 mark for final answer with unit
3.			Skills (two responses from): <ul style="list-style-type: none"> • Use material values (eg Young's Modulus, UTS) in structural calculations • Analyse results from materials test data • Simulate material/structural performance using computer software • Justify material choices as appropriate for given situation • Evaluate material performance Knowledge (two responses from): <ul style="list-style-type: none"> • Material properties • Material costs • Available material sections • Using values to influence design decisions 	4	2 marks for skills Only 1 mark available for each skill ie. Calculating, analysing, simulating, justifying and evaluating 2 marks for knowledge

Question		Expected response	Max mark	Additional guidance
4.	(a)	$R_A \sin 35 \times 7.0 = (1.0 \times 270) + (3.5 \times 270) + (6.0 \times 270)$ $R_A = 706.09595$ $R_A = 710 \text{ N (2 sf)}$	3	1 mark for R_{AV} component 1 mark for correct substitution 1 mark for final answer with unit
	(b)	Economic - Initial purchase cost of OLED/LED lamp compared to filament lamp are higher - Running energy cost reduced - Lifespan increased therefore fewer purchases Environmental - Lifespan is longer therefore less wastage as replaced less frequent - Energy consumption is less	2	1 mark for an economic impact with justification 1 mark for an environmental impact with justification Answers must be descriptive
5.	(a)	By altering the base current.	1	Accept "by the base current"
	(b)	$V_{GS} = 6 \times (4.8/8)$ $V_{GS} = 3.6$ $V_{Lamp} = 6 - 4.27$ $V_{Lamp} = 1.73$ $R = 1.73/0.0864$ $R = 20.0231$ $R = 20 \Omega$	3	1 mark for calculating V_{GS} 1 mark for calculating V_{Lamp} 1 mark for answer with unit, accept 20.0 Ω , 20.02 Ω .

Question	Expected response	Max mark	Additional guidance
6. (a)		9	<p>FTE if wrong symbol used repeatedly ie if “open barrier” is in a rectangle and not a parallelogram, lose first mark</p> <p>If it is in a rectangle later give mark</p> <p>1 mark for “is start switch...” decision box with correct Y/N directions</p> <p>1 mark for OPEN BARRIER</p> <p>1 mark for “is sensor high” decision box with correct Y/N directions</p> <p>1 mark for command(s) giving a count of 16</p> <p>1 mark for “is single rider option...” decision box with correct Y/N directions</p> <p>1 mark for “close barrier” and “open gate”</p> <p>1 mark for “is sensor high?” and count of 16 check</p> <p>1 mark for “Close gate”, “Close barrier” and Launch Switch</p> <p>1 mark for “motor on”, “delay 30s” and “motor off” and loop to start</p>

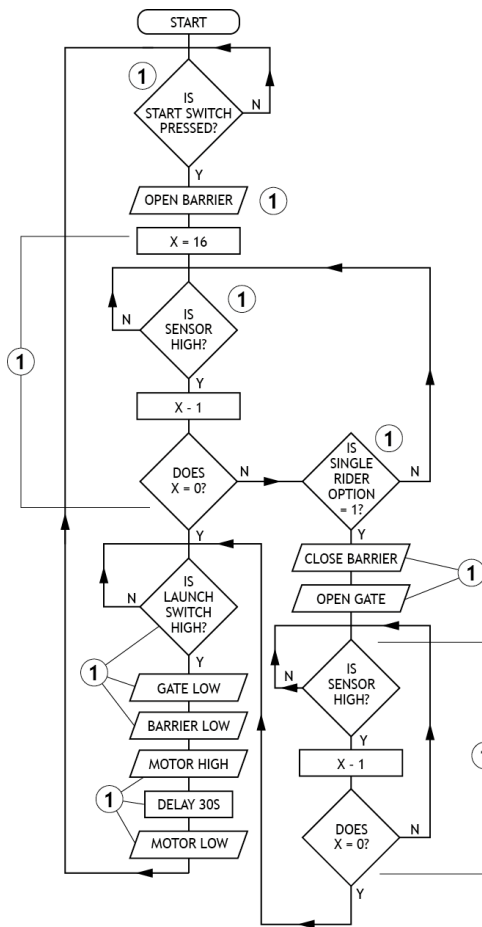

Question		Expected response	Max mark	Additional guidance
6.	(b)	UDL $2.5 \times 1.5 = 3.75$ Moments @ A $B \times 1.05 = (3.75 \times 0.75) + (0.98 \times 1.5)$ $B \text{ (horizontal)} = 4.0786$ Fv $A_v = 3.75 + 0.98$ $A_v = 4.73$ $A = \sqrt{(4.73^2 + 4.0786^2)}$ $A = 6.2456$ $A = 6.2 \text{ kN (2sf)}$ $\Theta = \tan^{-1} (4.73/4.0786)$ $\Theta = 49^\circ \text{ (2 sf)}$	5	1 mark for UDL no units required 1 mark for calculating horizontal component, no units required 1 mark for calculating vertical component, no units required 1 mark for calculating magnitude of A, units required 1 mark for calculating direction
	(c)	$Z = \bar{A} \oplus (B + C)$ Alternative answer $Z = \bar{A} \cdot \bar{B} \cdot \bar{C} + A \cdot \bar{B} \cdot C + A \cdot B \cdot \bar{C} + A \cdot B \cdot C$	3	(1 mark) for NOT A (1 mark) for B or C (1 mark) for EOR 1 mark for 1 correct expression 2 marks for 3 correct expressions 3 marks for 4 correct expressions $Z = \bar{A} \cdot \overline{(B+C)} + A \cdot (B+C)$
	(d)		3	(1 mark) for NOT A (1 mark) for B or C (1 mark) for EOR

Question		Expected response	Max mark	Additional guidance
7.	(a)	<p>Enable transmission of torque or motion from one shaft to another</p> <p>Where shafts meet at a slight angle, couplings are used to compensate for misalignment</p> <p>To allow for quicker maintenance of vehicles as motor can be removed from shaft quicker than removing the entire drive system</p>	2	<p>1 mark for cause</p> <p>1 mark for effect</p> <p>1 mark for only stating Joint connecting two shafts</p>
	(b)		3	<p>1 mark for error detector (negative error configuration)</p> <p>1 mark for output driver/driver/MOSFET driver</p> <p>1 mark for speed sensor, tachogenerator (not speedometer)</p>

Question		Expected response	Max mark	Additional guidance
7.	(c)	<p>The actual output is compared to the required output, with the actual level rising until greater than desired level</p> <p>Negative error detector attempts to correct for difference between desired output and actual output by amplifying the signal until it returns the actual output to match the desired setting</p> <p>Each time the system attempts to correct itself, it “over-shoots” slightly, before being corrected again - “lag”</p> <p>On each cycle of over-shooting and correction, the lag gradually reduces but is never removed</p>	3	<p>1 mark for each correct statement in a logical sequence up to a maximum of 3 marks</p>
		<p>Temperature</p> <p>LAG</p> <p>Actual temperature</p> <p>Set/Desire temperature</p> <p>Time</p> <p>(1)</p>		<p>Annotated diagram/graph (1) should:</p> <ul style="list-style-type: none"> 1 mark showing/describing actual and desired levels against time 1 mark showing/describing lag with constant correction 1 mark showing/describing reduction in lag over time
		<p>Temperature</p> <p>Set/Desire temperature</p> <p>Actual temperature</p> <p>Time</p> <p>(2)</p>		<p>Annotated diagram/graph (2) should:</p> <ul style="list-style-type: none"> 1 mark showing/describing actual and desired levels against time 1 mark showing/describing the gradient of the line reducing 1 mark showing/describing the actual temperature never settles on the desired temperature <p>If any of these features are missing, then supporting statements will be required to attract further marks</p>

Question		Expected response	Max mark	Additional guidance
7.	(d)	$\eta = 64500/60$ $\eta = 1075$ Power generated by flywheel $= 2\pi nT$ $= 2 \times 3.14 \times 1075 \times 18$ $= 121518$ (121580 using π) Output efficiency $\eta = P_{out}/P_{in} = 112.4/121.518$ $= 0.924966$ (0.924494 using π) $= 0.92$ (92%) (2 sf)	3	1 mark for calculating “n”, no units required 1 mark for calculating power, no units required 1 mark for calculation efficiency, unit required if expressed as percentage Apply FTE
	(e)	Initial kinetic energy: $E_k = 0.5 \times 2100 \times 31^2$ $= 1009050$ E_k after boost: $= 1009050 + 390000$ $= 1399050$ When car is brought to rest: $\Delta T = 249 - 23 = 226$ °C $E_h = mc\Delta T$ $1399050 = m \times 420 \times 226$ $m = 1399050/(420 \times 226)$ $= 14.73925$ $= 15$ kg (2 sf)	4	1 mark for calculating E_k , no units required. 1 mark for E_k after boost, no units required. 1 mark for ΔT , no units required 1 mark for m , units required. Apply FTE

Question			Expected response	Max mark	Additional guidance
8.	(a)	(i)	<p>Answers from:</p> <ul style="list-style-type: none"> • Encouragement of cycling as mode of transport brings improved physical health • Attractive landscaping supporting improved mental health • Encouragement of active play for children, potential physical benefits and improved group/peer relationships • Improved quality of life/relaxation opportunities through holidaymakers/recreational users of the canal • Improved quality of life/relaxation opportunities through use of water sports facilities • Employment opportunities through tourisms, eg shops, tours of attractions, etc • Any other reasonable response 	2	<p>Responses must be descriptive</p> <p>1 mark for each valid response</p>
		(ii)	<p>Answers from:</p> <ul style="list-style-type: none"> • Monitoring air quality for dust levels for impact on nearby residents or wildlife • Monitoring noise levels for impact on nearby residents • Monitoring water quality for impact of pollution from construction work • Monitoring levels of pollutants in soil for impact on wildlife and fauna • Specifying waste management and recycling procedures to limit environmental impact • Specifying drainage requirements to minimise environmental impact through polluted waters • Identification of endangered or protected wildlife/fauna, ensuring protection requirements are met • Identifying schemes to protect wildlife, eg safe animal crossings, tunnels, etc. • Any other reasonable response 	2	<p>Responses must be descriptive.</p> <p>1 mark for each valid response</p>

Question		Expected response	Max mark	Additional guidance
8.	(b)	$\Sigma F_h = 0,$ $\Rightarrow M1_h - M2_h = 0$ $\Rightarrow M1 \cos(45^\circ) - M2 \cos(80^\circ) = 0$ $\Rightarrow 0.707 M1 - 0.174 M2 = 0$ [eqn1] $\Sigma F_v = 0$ $\Rightarrow 0.49 - M1_v - M2_v = 0$ $\Rightarrow 0.49 - M1 \sin(45^\circ) - M2 \sin(80^\circ) = 0$ $\Rightarrow 0.49 - 0.707 M1 - 0.9848 M2 = 0$ [eqn 2] $0.49 - 1.15M2 = 0$ [eqn 1 + eqn 2] $\Rightarrow 1.1588 M2 = 0.49$ $\Rightarrow M2 = 0.49/1.1588$ $= 0.4229$ $= 0.42 \text{ MN (2 sf)}$ M1 is in COMPRESSION (STRUT) from eqn 1, $M1 = (0.174 \times 0.4229)/0.707$ $= 0.103366$ $= 0.10 \text{ MN (2 sf)}$	5	1 mark for equation 1 based on horizontal force components 1 mark for equation 2 based on vertical force components 1 mark for M2, unit required 1 mark for nature of M1 1 mark for M1, unit required Equations may be expressed in various ways, depending (eg) on which directions are taken as positive, and if sin has been used instead of cos (eg sin10 instead of cos80) and vice versa

Question			Expected response	Max mark	Additional guidance
8.	(c)	(i)	<p>Load on each bolt = $210\text{k}/6 = 35\text{ kN}$</p> <p>Safe working stress (sws) on bolt $= \text{UTS}/\text{FOS}$ $= 430/4.0$ $= 107.5\text{ Nmm}^{-2}$</p> <p>Cross-sectional area of bolt $A = F/\sigma$ $= 35 \times 10^3/107.5$ $= 325.6\text{ mm}^2$</p> <p>Diameter of bolt $= \sqrt{4A/\pi} = \sqrt{4 \times 325.6}/3.14$ $= 20.36$</p> <p>Required diameter 21 mm</p> <p>Alternative Method</p> <p>SWS = $430 / 4.0$ SWS = 107.5 N mm^{-2}</p> <p>$A = F/\sigma$ $A = 210000 / 107.5$ $A = 1953.49$</p> <p>Per bolt = $1953.49 / 6$ Per bolt = 325.6</p> <p>Diameter of bolt $= \sqrt{4A/\pi}$ $= \sqrt{4 \times 325.6} / \pi$ $= 20.36$</p> <p>Required diameter 21 mm</p>	4	<p>1 mark for load on each bolt, no unit required</p> <p>1 mark for SWS, no unit required</p> <p>1 mark for area, no unit required</p> <p>1 mark for required diameter, unit required (accept 20 mm)</p> <p>-----</p> <p>1 mark for SWS, no unit required</p> <p>1 mark for area, no unit required</p> <p>1 mark for area of each bolt, no unit required</p> <p>1 mark for required diameter, unit required (accept 20 mm)</p>
		(ii)	<p>$\epsilon = \sigma/E$ $= 107.5/196000$ $= 0.000548$</p> <p>$\Delta L = \epsilon \times L = 0.000548 \times 55$ $= 0.03014$ $= \mathbf{0.030\text{ mm (2 sf)}}$</p>	2	<p>1 mark for calculating strain</p> <p>If SWS is calculated in 8ci but candidate uses 430 mark is lost</p> <p>If SWS is not calculated in 8ci but candidate uses 430 mark is not lost</p> <p>1 mark for ΔL, unit required</p>

Question		Expected response	Max mark	Additional guidance
9.	(a)	<p>When vA is pressed, vC is actuated causing c1 to outstroke</p> <p>vA also actuates vE allowing air to exhaust through it but causing the outstroke speed to be slow</p> <p>Air must escape through a UDR due to the one-way valve</p> <p>Air cannot exhaust through vD as it has not been actuated</p> <p>When c1 is fully outstroked it actuates vF which resets vC and E.</p> <p>c1 will instroke quickly as air is able to go through the one-way valve unrestricted</p> <p>When vB is actuated it actuates vC causing c1 to outstroke</p> <p>vB also actuates vD which allows air to exhaust causing c1 to outstroke slowly</p> <p>When c1 is fully outstroked it actuates vF which resets vC and vD. c1 will instroke as air is able to go through the one-way valve unrestricted (1 mark in total)</p>	7	<p>1 mark for each correct point up to a maximum of 7.</p> <p>To gain full credit, 1 mark must correctly describe the speed at which c1 instrokes or outstrokes</p> <p>Where candidates have indicated that either vA or vB will cause c1 to outstroke in the same statement then 2 marks can be awarded</p>
	(b)	<p>The cylinder will outstroke more quickly than if only one valve was pressed</p> <p>This is because air can exhaust through both vD and vE simultaneously</p>	2	<p>1 mark for each point.</p> <p>Credit can be given if this has been described in part (a) but marks cannot be awarded to (a) and (b) for the same comment</p>
	(c)	<p>$6 \times 0.85 = 5.1V$</p> <p>$I_b = (5.1 - 0.7)/15000$ $= 0.000293$ $= 0.29 \text{ mA (2sf)}$</p>	3	<p>1 mark for correct output voltage from OA1</p> <p>1 mark for voltage over resistor</p> <p>1 mark for answer from given working</p>

Question		Expected response	Max mark	Additional guidance
9.	(d)	$h_{fe} = 25/0.29$ $= 86.2069$ $= \mathbf{86 (2\ sf)}$	1	No mark if answer given with a unit
	(e)	$R/1k = 1.5k/2.5k$ $R = 600\ \Omega$ <p>From graph, light level = 200 lux</p>	2	1 mark for resistance of LDR 1 mark for light level based on answer for R, unit required. (accept between 200-215)
	(f)	<p>When light level is low the voltage at the non-inverting inputs of each op-amp is low</p> <p>At this point the op-amps will both be saturated negatively</p> <p>When light level increases the voltage to the non-inverting input of OA2 will become greater than its reference so it will saturate positively</p> <p>This causes T2 to switch on</p> <p>When the light level increases further the voltage to the non-inverting input will be greater than the reference voltage at OA1 causing it to saturate positively</p> <p>This causes T1 to switch on</p>	3	1 mark for each valid comment up to a maximum of 3 For full credit, 1 mark must describe the light level increasing further for OA1 to saturate positively Candidates may refer to V_{ref} as the non-inverting input as illustrated in the databook, appropriate credit should be awarded
	(g)	<p>The input voltage can be small enough to switch T2 on but big enough to leave T1 off. Only vB will be actuated</p> <p>When T1 is switched on it cuts off the 12 V supply to the solenoid on vB.</p>	2	1 mark for explaining conditions for vB being on 1 mark for explaining conditions for vA being on

[END OF MARKING INSTRUCTIONS]