



National
Qualifications
2022

2022 Graphic Communication

Higher

Finalised Marking Instructions

© Scottish Qualifications Authority 2022

These marking instructions have been prepared by examination teams for use by SQA appointed markers when marking external course assessments.

The information in this document may be reproduced in support of SQA qualifications only on a non-commercial basis. If it is reproduced, SQA must be clearly acknowledged as the source. If it is to be reproduced for any other purpose, written permission must be obtained from permissions@sqa.org.uk.



General marking principles for Higher Graphic Communication

Always apply these general principles. Use them in conjunction with the specific marking instructions, which identify the key features required in candidates' responses.

- (a) Always use positive marking. This means candidates accumulate marks for the demonstration of relevant skills, knowledge and understanding; marks are not deducted for errors or omissions.
- (b) If a candidate response does not seem to be covered by either the principles or detailed marking instructions, and you are uncertain how to assess it, you must seek guidance from your team leader.
- (c) For 'Describe' questions
Candidates must provide a statement or structure of characteristics and/or or features, not just an outline or a list. For example, they can refer to a concept, experiment, situation or facts in the context of and appropriate to the question. The number of marks available for a question indicates the number of factual or appropriate points required.
- (d) For 'Explain' questions
Candidates must relate cause and effect and/or define relationships. This must be in the context of the question, or a specific area within the question.
- (e) For 'Compare' questions
Candidates must demonstrate knowledge and understanding of the similarities and/or differences between things, methods, or choices. This must be in the context of the question, or a specific area within the question.
- (f) Candidates can respond to any question using text, sketching, annotations or combinations of these. Award marks for the information conveyed. Do not award marks for the quality of sketching.

Marking instructions for each question

Question		Expected response	Max mark	Additional guidance
1.	(a)	<ul style="list-style-type: none"> • Provides a more realistic view of the proposed project • Easier to interpret than 2D drawings • Clients can view proposed project from any angle or direction • Clients can use zoom function to see more detail • Gives a sense of scale • Clients can evaluate lighting • Realistic representation of materials • Communicates three dimensions more effectively • Allows for remote discussion or communication with clients 	2	<ul style="list-style-type: none"> • Do not accept send via email. • Do not accept environmental issues, such as no use of paper, ink etc.
	(b)	<ul style="list-style-type: none"> • The sketches could include realistic material representations • They can be built up in a series of layers to ease editing • They are automatically stored electronically and do not require scanning using hardware • Able to show clients changes instantly • Sketches can be exported to other packages • Easy to share through email • More sketching tools available, such as brushes, materials, and colours 	2	<ul style="list-style-type: none"> • Do not accept generic 'quicker or easy to change' descriptions, must give an example such as layers can be used or turned on or off etc. • Candidates must mention a method of sharing.
	(c)	(i) <ul style="list-style-type: none"> • Reduce time required as symbols are not created repeatedly • Reduce likelihood of CAD technician making errors as parts or symbols do not need to be remodelled or redrawn • A library would contain all commonly used symbols meaning they would be standardised or commonly understood • The library can be used by all CAD technicians in the company meaning consistency across all drawings 	2	<ul style="list-style-type: none"> • Candidates must have two valid explanations (cause and effect).

Question			Expected response	Max mark	Additional guidance
1.	(c)	(ii)	<ul style="list-style-type: none"> DXF may need to be accessed, viewed and or referenced by an application that is not capable of opening other file types Many applications can open a DXF file as it a commonly used file format. The type of information being conveyed is 2D line work and text, and is the type of information that a DXF is designed to handle DXF is a vector graphic and so can be scaled without losing quality 	1	<ul style="list-style-type: none"> Candidates must have a valid explanation (cause and effect). Do not accept references to file sizes.
	(d)	(i)	<ul style="list-style-type: none"> Handheld scanner Digital camera Digital camera on a mobile device 	1	<ul style="list-style-type: none"> Candidates do not need to say 'digital'. If response includes a mobile device, candidates must refer to a camera function.
		(ii)	<ul style="list-style-type: none"> No purchasing costs No issues concerning copyright of image The company are not restricted by the stock images available The company can capture images which suit their needs exactly The image can be captured in the correct orientation (portrait, landscape) Photos will show quality of their own work 	3	
	(e)	(i)	Box array	1	<ul style="list-style-type: none"> Accept "box" on its own
		(ii)	<ul style="list-style-type: none"> 50 (1 mark) 60 (1 mark) 	2	
		(iii)	Offset	1	

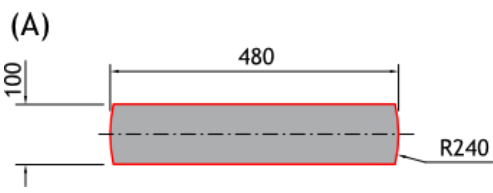
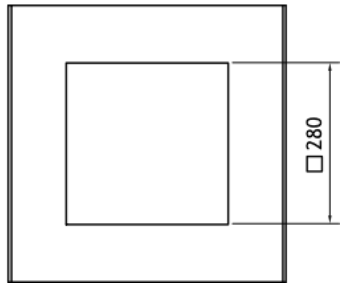
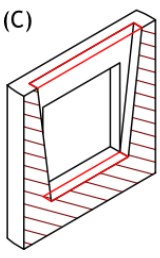
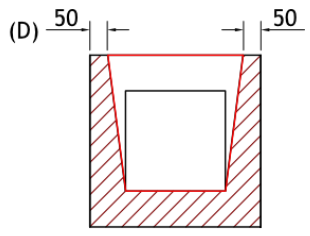
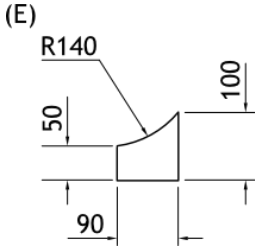
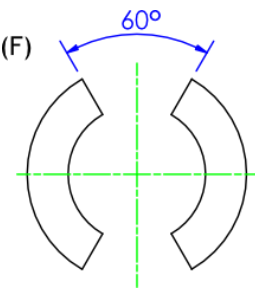
Question	Expected response	Max mark	Additional guidance
(f)	<p>Central Column</p> <ul style="list-style-type: none"> Profile created with correct dimensions (A) (1 mark) Extrude profile 480 (1 mark) □280 profile in correct position and extrude subtract 100 (B) (1 mark) <p>Tapered Hole <i>Either Loft subtract (C)</i></p> <ul style="list-style-type: none"> Sketch on top surface 380 x 30 and sketch 280 x 30 on bottom of hole or offset workplane by 380 (1 mark) Loft to subtract between profiles (1 mark) <p><i>or Extrude subtract (D)</i></p> <ul style="list-style-type: none"> Tapered profile 380 at top, 280 at bottom, 50 at sides, 380 tall (1 mark) Extrude subtract 30 from offset workplane 35 from front or back surface (1 mark) <p>Feet</p> <ul style="list-style-type: none"> Correct profile with all dimensions (E) (1 mark) Notice taken of both 60 gaps (F) (1 mark) Feet have been modelled symmetrically on both sides of the bench (F) (1 mark) 	8	<p>(A)</p>  <p>(B)</p>  <p>(C)</p>  <p>(D)</p>  <p>(E)</p>  <p>(F)</p>  <p>Candidates should be awarded marks for successfully modelling the object, other modelling techniques can be used eg extrude along a path, extrude subtract to remove 60° wedge.</p>

Question		Expected response	Max mark	Additional guidance
2.	(a)	<ul style="list-style-type: none"> • Geometry or dimensions can be projected to ensure an exact fit between the components • Components can be modelled in situ and will not need constraints to assemble • Any changes to one component will dynamically change the other component(s) 	2	
	(b)	<ul style="list-style-type: none"> • Components are modelled individually • They can be inserted into an assembly to assemble using constraints • Any changes to a component will need to be done by editing it individually 	2	
	(c)	Intersect	1	
	(d)	Move shell before extrude subtract	1	
	(e)	<ul style="list-style-type: none"> • Four profiles: ellipse (maj 60 and min 40), Ø60, Ø70, Ø70 (1 mark) • Profiles sketched on offset workplanes 20, 30 and 6 (1 mark) • Loft (1 mark) • Shell (thickness 3) removing top face (1 mark) • Profile on top surface R40 and 35 wide, extrude 6 (1 mark) • Ø20 on bottom face and extrude subtract 3 (1 mark) 	6	<ul style="list-style-type: none"> • Shell must be applied before 'handles'
	(f)	<ul style="list-style-type: none"> • Profile Ø8 and Ø4 (1 mark) • Correct path sketched on perpendicular workplane (30, 20, 50 and 45) (1 mark) • Extrude or sweep along a path (1 mark) • R2 profile (10 from bottom and 4 from centre axis) and revolve (1 mark) 	4	<ul style="list-style-type: none"> • If using shell candidates must have Ø8 profile, wall thickness of 2 and remove top and bottom faces for first mark • Candidates should be awarded marks for successfully modelling the object, other modelling techniques can be used eg offset workplane with an extrude then fillet

Question			Expected response	Max mark	Additional guidance
2.	(g)	(i)	<p>Any of the following uses of alignment:</p> <ul style="list-style-type: none"> • Alignment of coffee cups at top or bottom or LHS or RHS • Alignment of coffee cups and “REWARDS” at top • Alignment of company logo and coffee cups at LHS or RHS • Alignment of rows of white squares at top or bottom or centre or RHS or LHS • Alignment of top row of white squares and white text at bottom • Alignment of company logo and “loyalty card” text at top • Alignment of company logo and “MyCoffee” text at bottom • Alignment of pink and white text at RHS • Alignment of white text and white line at RHS or LHS. <p>Any of the following improvements to layout:</p> <ul style="list-style-type: none"> • Creates neatness, structure or formality in layout • Creates an organised layout • Makes layout easier to follow or read. 	2	One example of a use (cause) with an improvement (effect) will gain one mark

Question		Expected response	Max mark	Additional guidance
	(ii)	<p>Any of the following uses of depth:</p> <ul style="list-style-type: none"> • Drop shadow added to white squares or MyCoffee • Background layer added • Use of transparency over background texture • Use of transparency with white coffee bean stamp • Red bands under coffee cups • Descenders in coffee of logo overlaps • White shadow around coffee bean. <p>Any of the following improvements to layout:</p> <ul style="list-style-type: none"> • Drop shadow or layering makes element stand out or creates emphasis • Drop shadow or transparency gives impression of three-dimensions • Drop shadow or transparency creates visual interest • White shadow draws attention to symbol. 	2	One example of a use (cause) with an improvement (effect) will gain one mark

Question			Expected response	Max mark	Additional guidance
2.	(g)	(iii)	<p>Any of the following uses of unity:</p> <ul style="list-style-type: none"> • Unity of colour across two separate elements • Unity of white in coffee bean stamp and any other white element • Unity of font: “loyalty card” and “coffee” script font • Unity of shape through repeated coffee cup or white squares or red bands. <p>Any of the following improvements to layout:</p> <ul style="list-style-type: none"> • Help link elements together • Improves consistency in layout • Makes the layout easier to follow. 	2	One example of a use (cause) with an improvement (effect) will gain one mark
	(h)		<ul style="list-style-type: none"> • To allow the multicolour (CMYK) printing to be set up correctly • To allow checking of alignment of print stages • Each registration mark should overprint exactly for accurate registration • Correct alignment of secondary process eg trimming 	2	

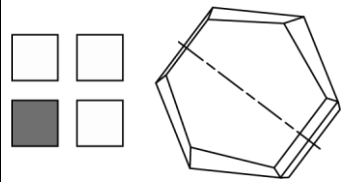
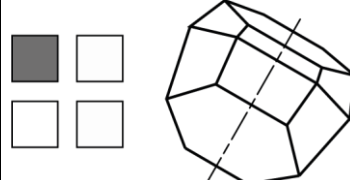
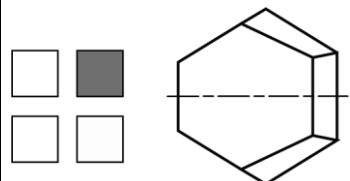
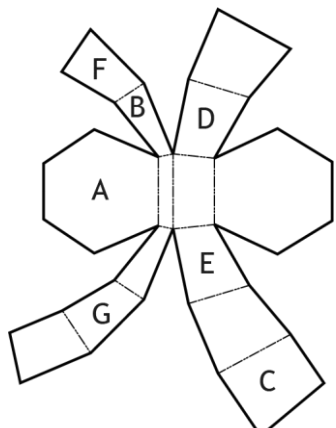
Question		Expected response	Max mark	Additional guidance
3.	(a)		1	
	(b)		1	
	(c)		1	
	(d)		7	

Question		Expected response	Max mark	Additional guidance
4.	(a)	<p>Symmetrical balance is created as:</p> <ul style="list-style-type: none"> • Text and images are arranged either side of a central rule in each section • Similar sizes of text and images on either size • The coloured K graphic in the top left is balanced out by the triangular graphic diagonally opposite. <p>Asymmetrical balance is created as:</p> <ul style="list-style-type: none"> • Different sizes and shapes of text and images are staggered left to right working down the page. 	2	Candidates must reference symmetrical or asymmetrical to be awarded a mark.
	(b)	<p>The use of white space has:</p> <ul style="list-style-type: none"> • Contributed to the modern or minimal feel of the layout • Creates a less busy or cluttered layout • Created a relaxed feel to the layout that is restful or does not overstimulate the viewer • Allows other elements to stand out • Allows reader's eyes to rest. 	2	<ul style="list-style-type: none"> • Do not accept "easy to read" without description.
	(c)	<p>Shape has been used to:</p> <ul style="list-style-type: none"> • Creates visual interest • Draws attention to or emphasises sections of the layout • Creates contrast • Creates unity • Creates depth • Red circle ties in with Japanese theme due to similarity with Japanese flag. 	2	<ul style="list-style-type: none"> • Must be two different effects to achieve 2 marks.
	(d)	<p>Transparency has been used to:</p> <ul style="list-style-type: none"> • Create a sense of depth • Draw attention to specific elements of the layout • Create visual interest • Allows images to still be seen through coloured shapes. 	2	<ul style="list-style-type: none"> • Must be two different effects to achieve 2 marks.

Question			Expected response	Max mark	Additional guidance
4.	(e)	(i)	Square crop or cropping	1	
		(ii)	Full crop or cropping	1	
		(iii)	<p>Any of the following regarding the square crop (1 mark):</p> <ul style="list-style-type: none"> To frame a specific area of the image or focus on subject of the image To remove an unwanted area of the image To allow the image to fit the available space within the layout. <p>Any of the following regarding the full crop (1 mark):</p> <ul style="list-style-type: none"> To apply own background To remove clutter To provide an irregular outline To create visual interest To create contrast To create layering. 	2	<ul style="list-style-type: none"> Must have one example for each. Must be a different effect for each type of crop. Apply follow on rule from 4(e) (i) and (ii) if correct effect described.
	(f)		<p>Placeholder text:</p> <ul style="list-style-type: none"> Speeds up the process of creating layouts as the graphic artist does not need to manually type the text required Allows the graphic artist to consider placement of text without being distracted by the readable content of a page Allows the graphic artist to consider size to see how much space would be needed Allows graphic artist to consider typeface to see what style would suit the theme of the layout. 	2	<p>One valid reason for use with no explanation gains 1 mark.</p> <p>Two valid reasons for use with no explanation gains 1 mark.</p> <p>One valid reason with an explanation gains 2 marks.</p>

Question		Expected response	Max mark	Additional guidance
4.	(g)	<p>Any two from:</p> <ul style="list-style-type: none"> • Text and images can be edited separately • Layers can be turned off and on to improve clarity during the production of the layout • The layers can provide a master page for similar future layouts that may be required • Layers can be edited without affecting other elements of the layout • Layers can be ordered by either moving backwards or forwards • Layers can be locked to prevent them from being edited or moved by mistake. 	2	
	(h)	<p>Any two from:</p> <ul style="list-style-type: none"> • Can view embedded content (movie clip) to interact with it • Easy to zoom in or increase size of font to improve accessibility • Can expand areas of text to 'read more' allowing more information to be included • Can view linked material (social media platforms) allowing better user engagement • Available in a range of languages broadening target audience • Built in accessibility features such as text to speech allows more people to access content • Can copy and paste content making it easier to share • Can be read in different lighting conditions, such as in the dark, with justification eg device can be backlit, brightness level can be adjusted. 	2	<ul style="list-style-type: none"> • Candidates must have two valid explanations (cause and effect). • Must be a benefit to the consumer of reading online. • Do not accept environmental considerations.

[END OF MARKING INSTRUCTIONS]