

FOR OFFICIAL USE



National
Qualifications
2017

Mark

X723/75/01

Engineering Science

THURSDAY, 25 MAY

1:00 PM – 2:30 PM



* X 7 2 3 7 5 0 1 *

Fill in these boxes and read what is printed below.

Full name of centre

Town

Forename(s)

Surname

Number of seat

Date of birth

Day

Month

Year

Scottish candidate number

Total marks — 90

SECTION 1 — 20 marks

Attempt ALL questions.

SECTION 2 — 70 marks

Attempt ALL questions.

Show all working and units where appropriate.

You should refer to the National 4/5 Engineering Science Data Booklet which you have been given.

The number of significant figures expressed in a final answer should be equivalent to the least significant data value given in the question. Answers that have two more figures or one less figure than this will be accepted.

Write your answers clearly in the spaces provided in this booklet. Additional space for answers is provided at the end of this booklet. If you use this space you must clearly identify the question number you are attempting.

Use **blue** or **black** ink.

Before leaving the examination room you must give this booklet to the Invigilator; if you do not, you may lose all the marks for this paper.



* X 7 2 3 7 5 0 1 0 1 *

SECTION 1 — 20 marks

Attempt ALL questions

1. A sub-system diagram for a hand held fan is shown below.

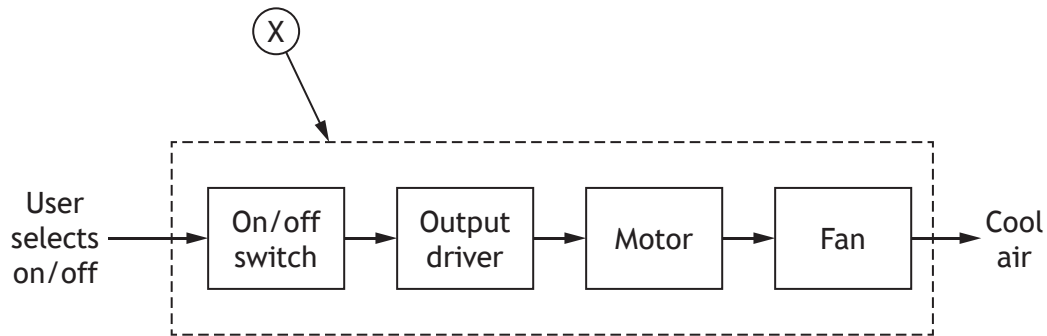

(a) State the type of control used in this system. 1

(b) State the name of (X). 1

2. A logic diagram is shown below.

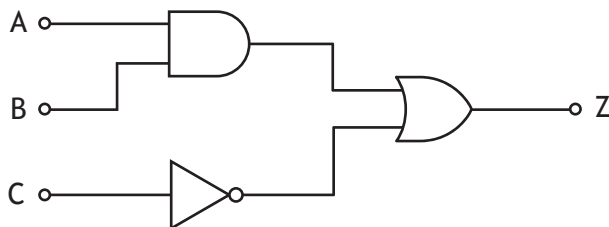

Complete the Boolean equation for this logic diagram. 3

Z = _____



3. A warning circuit is designed to activate a buzzer when a switch is pressed.

(a) Complete the circuit below by adding the symbol for a buzzer in the position shown.

1

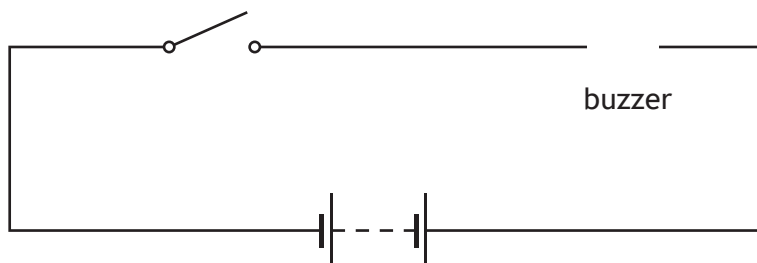

(b) State the name of the equipment used to measure the current in a circuit.

1

4. A 5.4 kg bowling ball travels down a lane at 8.2 ms^{-1} .

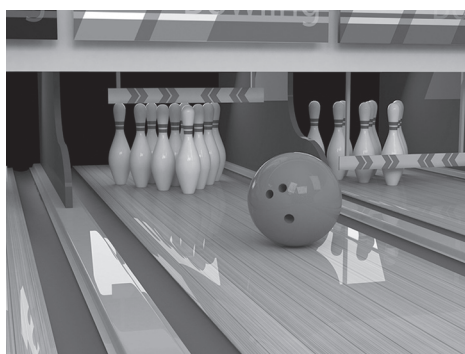

Calculate the kinetic energy of the bowling ball.

2



5. A clock is hung from a frame structure and is shown below.

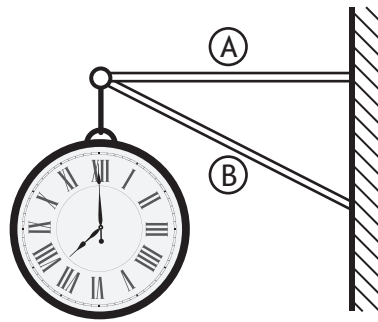

(a) State the nature of the force in: 2

Member (A) _____

Member (B) _____

(b) The clock has a mass of 2.2 kg.
Calculate the downward force of the clock ($F = mg$). 2

6. A pneumatic circuit used to crush materials in a recycling factory is shown below.

The piston should only outstroke when valve ① and valve ② have been actuated. It will then instroke when valve ③ has been actuated.

Complete the piping of the pneumatic circuit shown below.

3

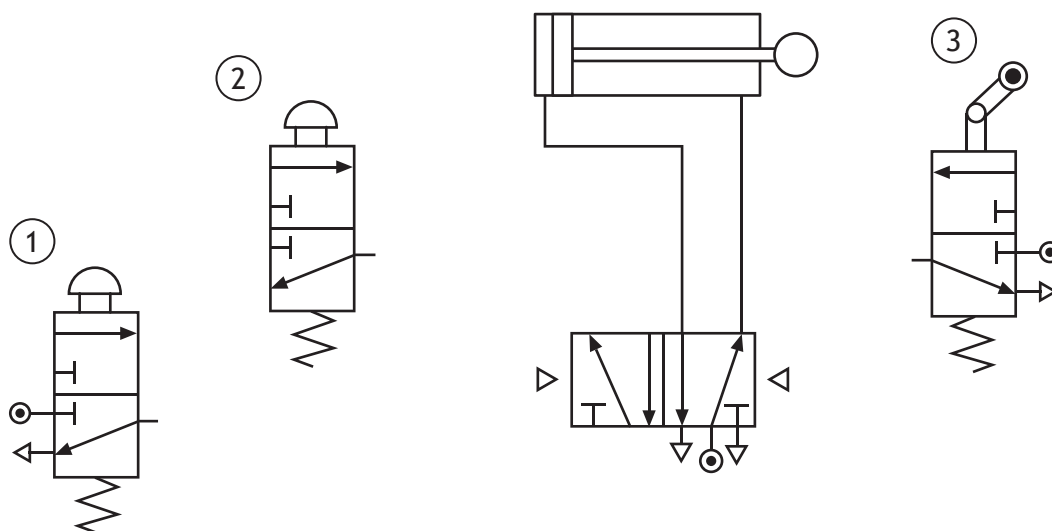

[Turn over



* X 7 2 3 7 5 0 1 0 5 *

7. A simple gear train used in a winch system is shown below.

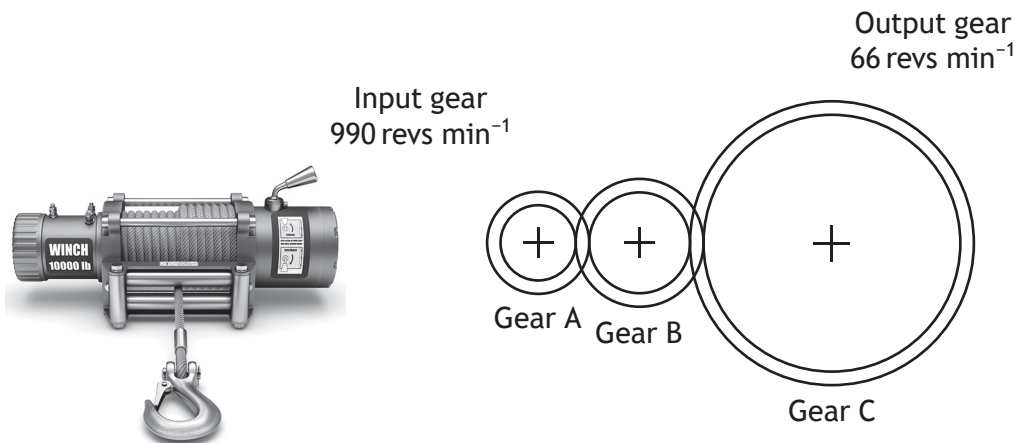

- (a) (i) State the name of gear B. 1
- _____
- (ii) State the effect of gear B on the output speed. 1
- _____
- (b) Calculate the velocity ratio of the gear train. 2

[Turn over for next question

DO NOT WRITE ON THIS PAGE



* X 7 2 3 7 5 0 1 0 7 *

SECTION 2 — 70 marks

Attempt ALL questions

8. The circuit used in a museum lighting system is shown below.

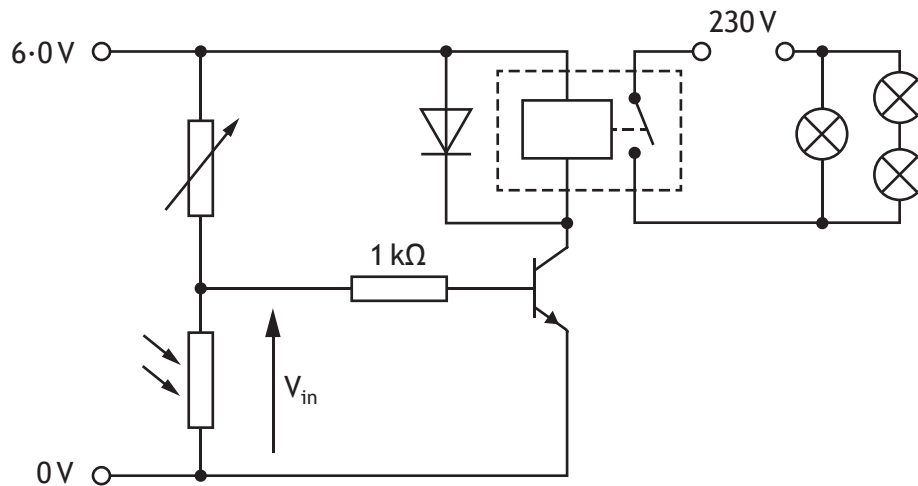

- (a) Describe the operation of the **voltage divider**, as the light level increases. Make reference to the LDR's resistance and the voltage V_{in} .

2

As the light level increases _____

- (b) Describe the **function** of the transistor in this circuit.

1

- (c) During simulation of the circuit the transistor was found to stop working. Describe the fault in the above circuit that results in the transistor failing.

1



8. (continued)

(d) Three lamps suspended from the museum ceiling are shown below.

The weight of the lamps create a strain in the supporting cable of 0.00056 and an extension of 0.34 mm.

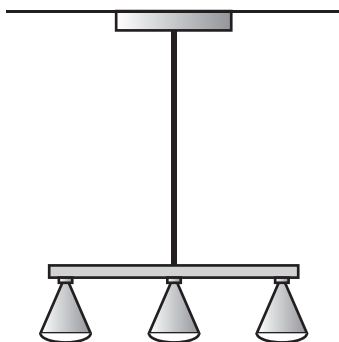

Calculate the original length of the cable.

3

[Turn over



* X 7 2 3 7 5 0 1 0 9 *

9. A question display board in a television game show is operated by a microcontroller. Contestants are shown a question and given 10 seconds to answer.

The system must perform the following sequence:

- When the host presses a question switch, a display turns on showing the question.
- When the host presses a timer start switch, an LED will pulse on and off 16 times over an 8 second period.
- A buzzer will then sound for 2 seconds.
- The buzzer and display board then turn off.
- The system then restarts ready for the next question.

Input and output connections to the microcontroller are shown in the table below.

Input Connection	Pin	Output Connection
	7	Display board
	6	LED
	5	Buzzer
Timer start switch	1	
Question switch	0	



* X 7 2 3 7 5 0 1 1 0 *

9. (continued)

MARKS

DO NOT
WRITE IN
THIS
MARGIN

Complete, with reference to the Data Booklet and the input and output connections shown, the flowchart for the control sequence. Include **all** pin numbers in your flowchart.

9

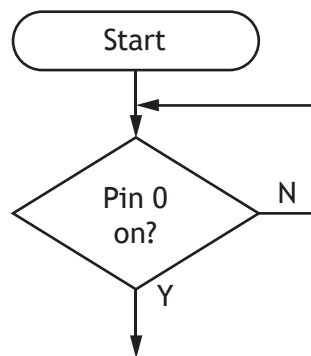

* X 7 2 3 7 5 0 1 1 1 *

10. A boiling water tap and heating tank is shown below. It is installed in a busy office kitchen, where 200 staff can make hot drinks throughout the day. The boiling water tap produces boiling water instantly.

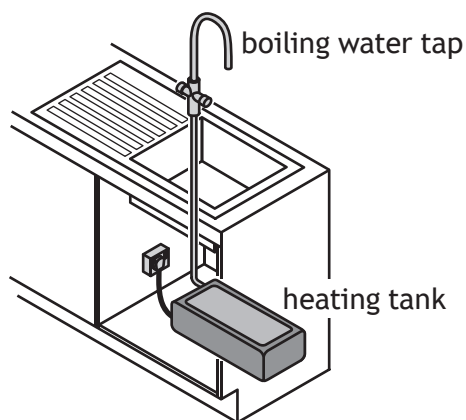

Water is boiled in the heating tank and then stored until it is ready to be used. 1.4 MJ of electrical energy is used when heating a full tank of water for the first time.

- (a) (i) Calculate the output energy of the system if it is 82% efficient. 3

- (ii) Calculate, with reference to the Data Booklet, the mass of water in a full tank when the change in temperature is 91 °C. 3

10. (continued)

(b) The temperature of the water is monitored by an electronic circuit.

Describe two **tasks** an **Electronic Engineer** would have undertaken when **designing** this circuit.

2

1 _____

2 _____

(c) Boiling water taps are often installed in offices as an alternative to kettles.

Describe a positive and negative **economic** impact of installing and using a boiling water tap.

2

Positive _____

Negative _____

[Turn over



* X 7 2 3 7 5 0 1 1 3 *

11. A pneumatic circuit used to process components on a production line is shown below.

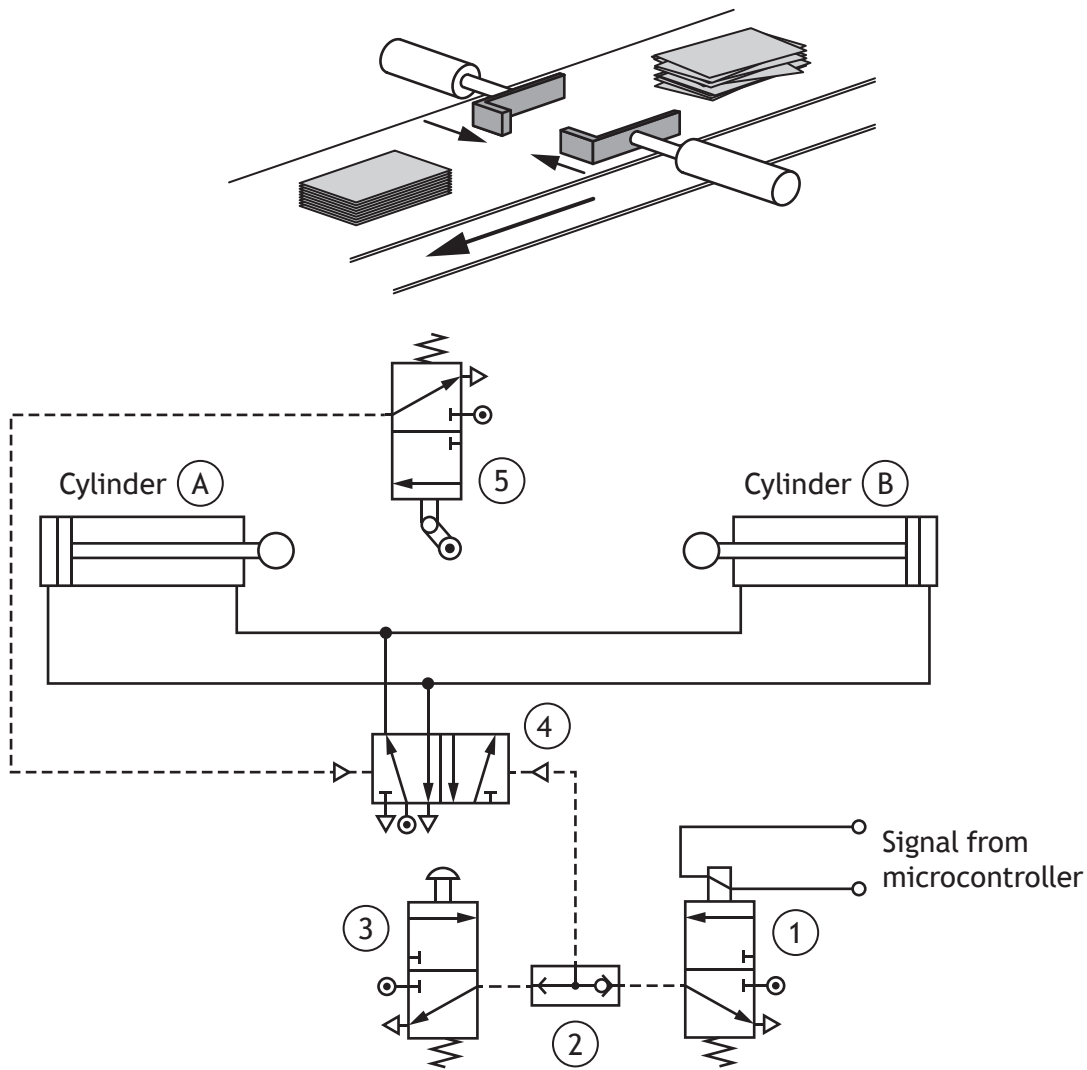

(a) Describe, using appropriate terminology, the operation of the circuit.

3



* X 7 2 3 7 5 0 1 1 4 *

11. (continued)

- (b) An adjustable time delay is required for the circuit.

Draw a unidirectional restrictor and reservoir to create an adjustable time delay.

3

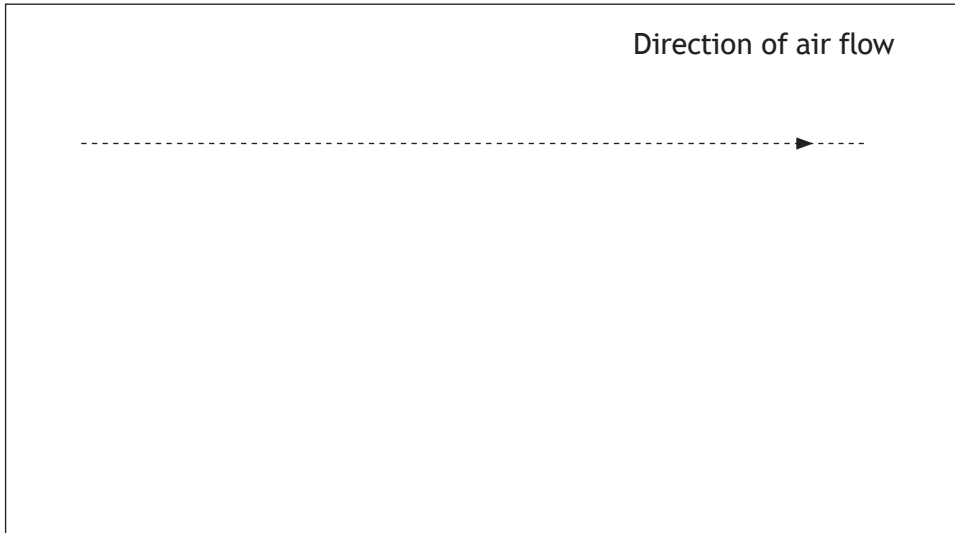

- (c) A piston rod has a diameter of 16 mm and experiences a stress of 3.4 Nmm^{-2} when fully outstroked.

Calculate the force in the piston rod.

4

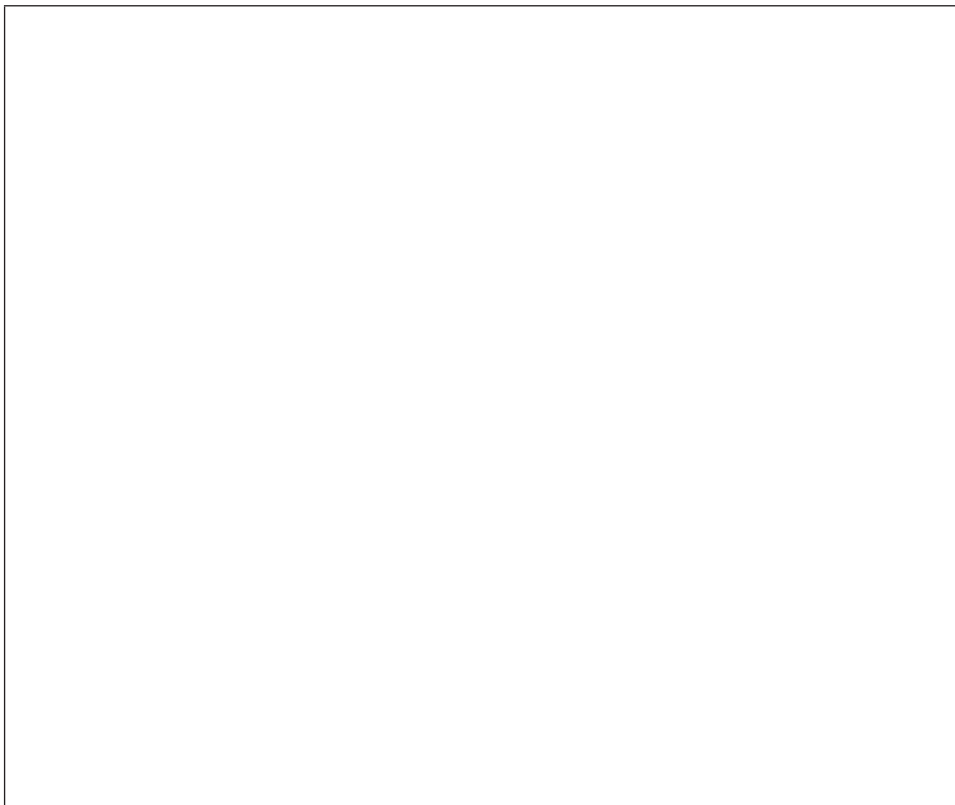

12. Part of an electronic circuit used in a self-balancing scooter is shown below.

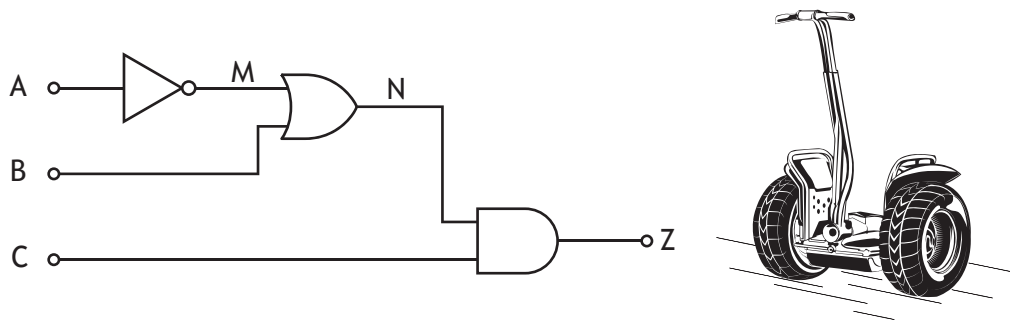

(a) Complete the truth table for this circuit.

3

A	B	C	M	N	Z
0	0	0			
0	0	1			
0	1	0			
0	1	1			
1	0	0			
1	0	1			
1	1	0			
1	1	1			

(b) The Boolean equation for a second electronic circuit used in the scooter is shown below.

$$Z = (D \cdot \bar{E}) + F$$

Draw the logic diagram for this Boolean equation.

3

D ○

E ○

○ Z

F ○



12. (continued)

(c) The mechanical system used in the scooter is shown below.

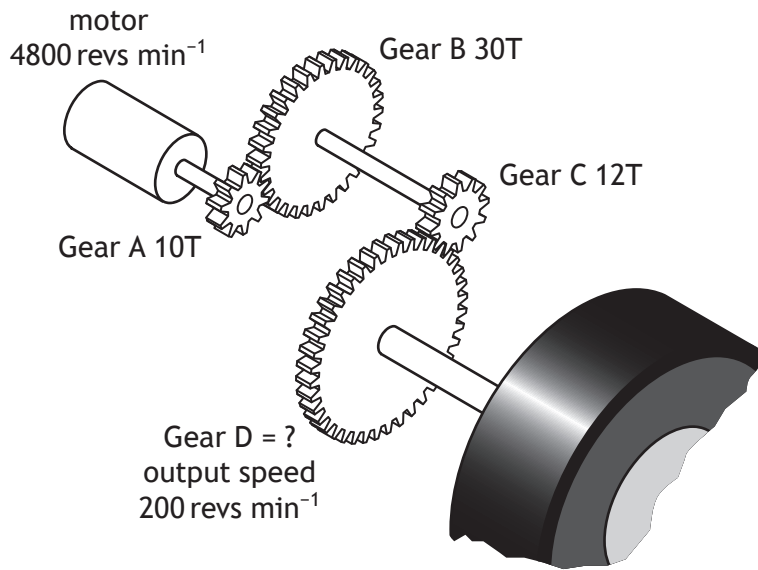

Calculate the number of teeth on gear D.

4

(d) Explain how this mechanical system could be made more efficient.

2



13. A garden centre is planning to extend its building to include space for a new café. The extension will include solar panels and a system to heat/cool the café.



- (a) Describe the role of each of the following engineers during the **development** stage of this project.

(i) Structural Engineer

1

(ii) Electrical Engineer

1

- (b) Describe two **environmental** advantages of installing and/or using solar panels.

2



* X 7 2 3 7 5 0 1 1 8 *

13. (continued)

(d) The graph below shows the behaviour of a range of thermistors considered for use in the heating/cooling system.

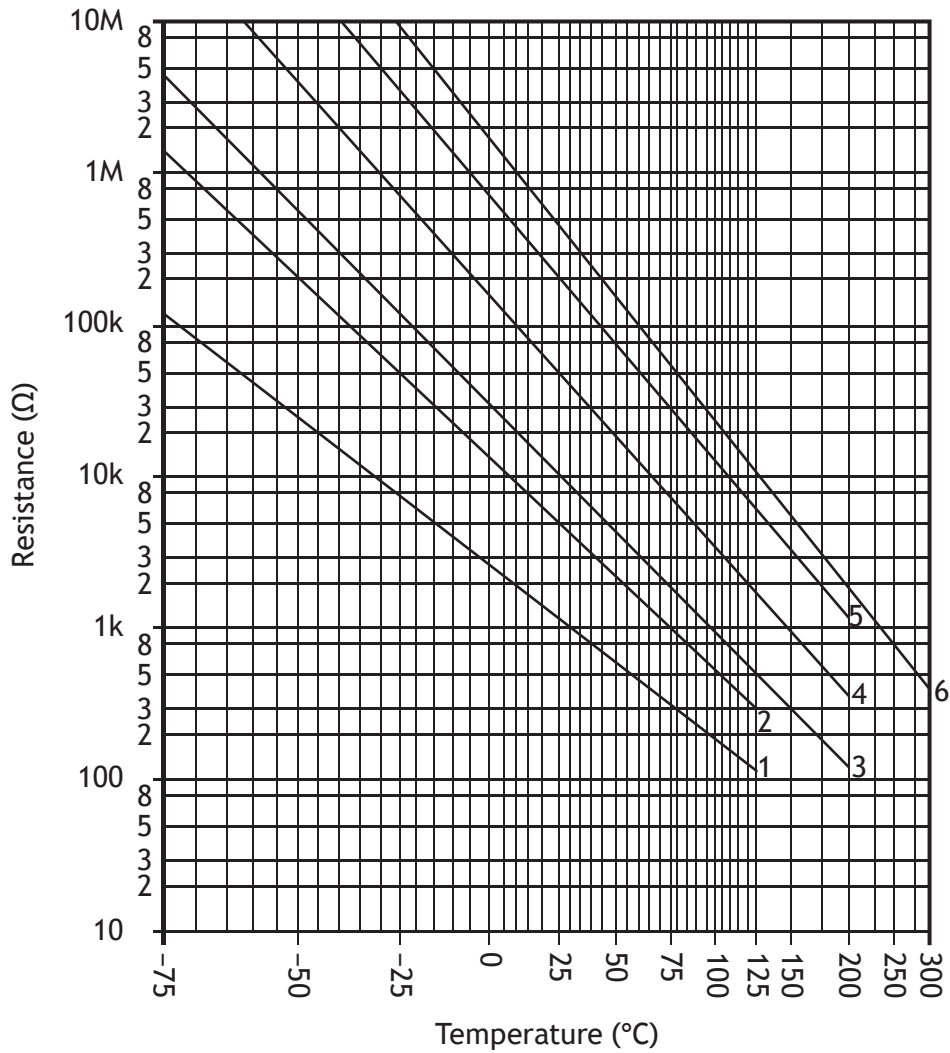

Determine, with reference to this graph, the resistance of the type 1 thermistor at 40 °C.

1



* X 7 2 3 7 5 0 1 2 0 *

13. (continued)

- (e) The sensing circuit, with readings taken at a temperature of 10°C , is shown below.

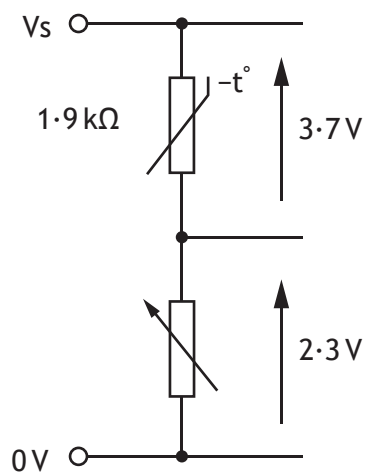

Calculate the resistance of the variable resistor for these conditions.

3



* X 7 2 3 7 5 0 1 2 1 *

14. A motorway gantry with a traffic management sign hung over one lane is shown below.

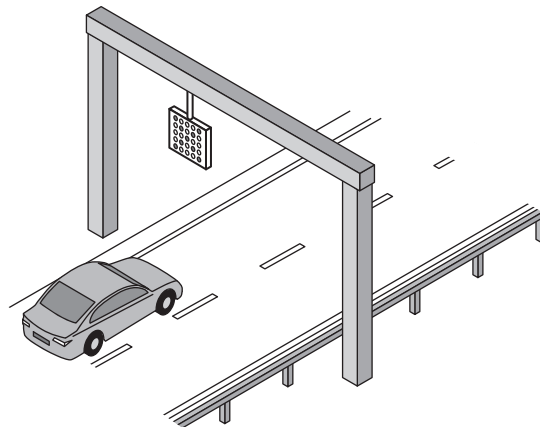

The sign produces a downward force of 5.2 kN and the weight of the gantry itself is 22 kN.

A free body diagram representing the structure is shown below.

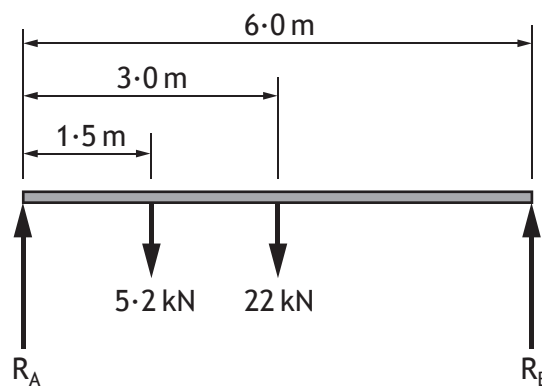

- (a) Calculate the reaction force R_B by taking moments about R_A .

3



14. (continued)

- (b) The sign hangs on a metal support. The following materials were considered for the support during the design of the sign.

Material	Maximum Tensile Load	Maximum Compressive Load	Corrosion Resistant
Metal A	4.8 kN	4.8 kN	Yes
Metal B	5.6 kN	5.1 kN	Yes
Metal C	3.6 kN	5.5 kN	No
Metal D	5.2 kN	6.2 kN	No

Select the most suitable metal (A-D) from the table to be used for the support and justify your choice.

2

Choice of metal _____

Reason for choice _____

- (c) Describe a positive **social** impact of using the traffic management sign.

1

[Turn over for next question



14. (continued)

(d) The circuit for one LED on the sign is shown below.

Output from microcontroller 5.0V

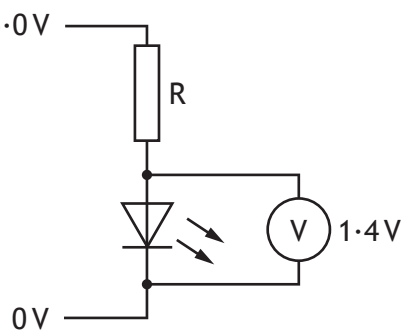

Calculate the value of the resistor R to limit the current to 15 mA.

4

[END OF QUESTION PAPER]



* X 7 2 3 7 5 0 1 2 4 *

MARKS

DO NOT
WRITE IN
THIS
MARGIN

ADDITIONAL SPACE FOR ANSWERS



* X 7 2 3 7 5 0 1 2 5 *

MARKS

DO NOT
WRITE IN
THIS
MARGIN

ADDITIONAL SPACE FOR ANSWERS



* X 7 2 3 7 5 0 1 2 6 *

[BLANK PAGE]

DO NOT WRITE ON THIS PAGE



* X 7 2 3 7 5 0 1 2 7 *

[BLANK PAGE]

DO NOT WRITE ON THIS PAGE

Acknowledgement of Copyright

Question 1	Diana Rich/shutterstock.com
Question 4	Bessarab/shutterstock.com
Question 5	Viktorija Reuta/shutterstock.com
Question 7	Slavoljub Pantelic/shutterstock.com
Question 13	jessicakirsh/shutterstock.com



* X 7 2 3 7 5 0 1 2 8 *