

FOR OFFICIAL USE



National
Qualifications
2024

Mark

X861/75/02

Practical Metalworking

WEDNESDAY, 29 MAY

1:00 PM – 2:00 PM



* X 8 6 1 7 5 0 2 *

Fill in these boxes and read what is printed below.

Full name of centre

Town

Forename(s)

Surname

Number of seat

Date of birth

Day

Month

Year

Scottish candidate number

Total marks — 60

Attempt ALL questions.

You may use a calculator.

Write your answers clearly in the spaces provided in this booklet. Additional space for answers is provided at the end of this booklet. If you use this space you must clearly identify the question number you are attempting.

Use **blue** or **black** ink.

Before leaving the examination room you must give this booklet to the Invigilator; if you do not, you may lose all the marks for this paper.



* X 8 6 1 7 5 0 2 0 1 *

Total marks — 60
Attempt ALL questions

1. A headphone stand, made of four separate parts, is shown below.

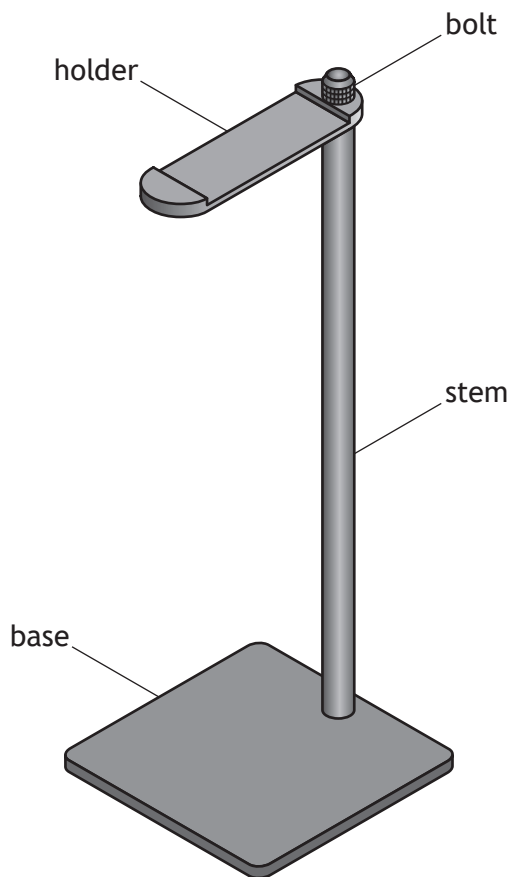

The metals listed below were considered for the parts of the headphone stand before manufacture.

(a) Identify the correct category of each metal shown by ticking (✓) a box in the table below.

3

The first one has been completed for you.

Metal	Ferrous	Non-ferrous	Alloy
Brass			✓
Nickel			
Mild steel			
Aluminium			

1. (continued)

Four properties of metal are shown below.

Brittleness

Malleability

~~Toughness~~

Hardness

(b) Identify the correct property by completing the table below.

3

The first one has been completed for you.

Description	Type of property
Huge energy is required to break the material. It can resist sudden blows, bends or twists.	Toughness
Metal resists penetration, cutting or scratching.	
Metal can be hammered, rolled or pressed into thin sheets or small bars without cracking or breaking.	
Metal is easily broken when struck, with little or no bending at the breaking point.	

[Turn over



1. (continued)

The tool shown below was used to manufacture the headphone stand.

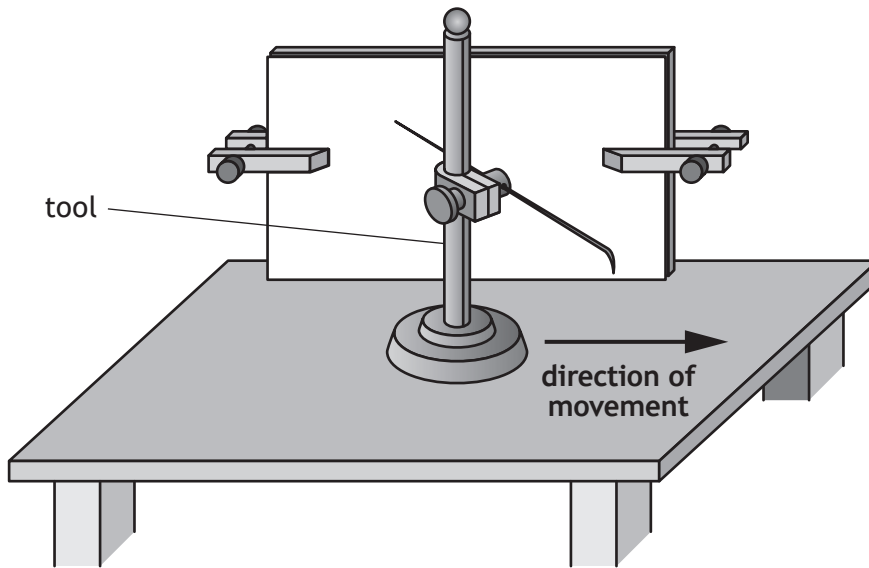

(c) (i) Name the tool.

1

(ii) Explain why the tool should be moved in the direction shown by the arrow.

1

(d) Explain why a **datum line** is used when measuring and marking.

1

1. (continued)

The base and stem will be screwed together as shown below.

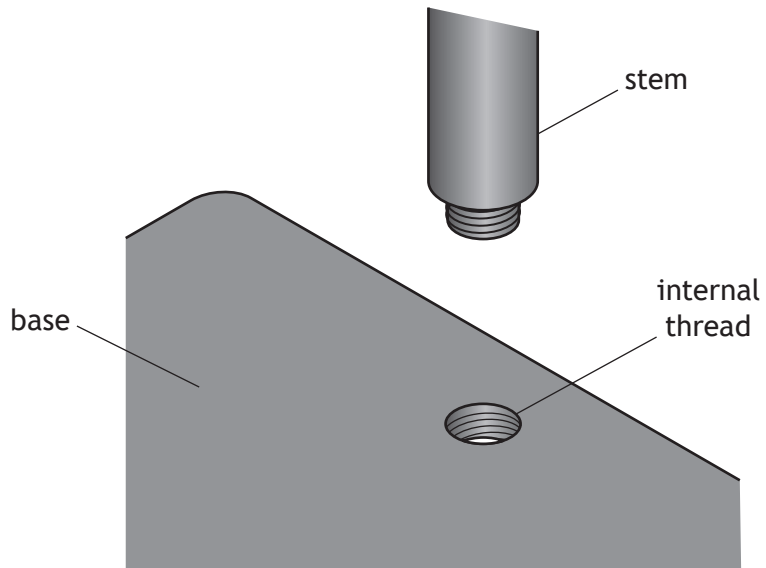

The through hole for the internal thread has been drilled on the pillar drill.

(e) Describe how to accurately cut the internal thread in the base.

You must make reference to all tools and processes.

You may use sketches to support your answer.

4

Blank area for the student's answer to question (e).

1. (continued)

The sides of the base have been finished to an accurate and high standard.

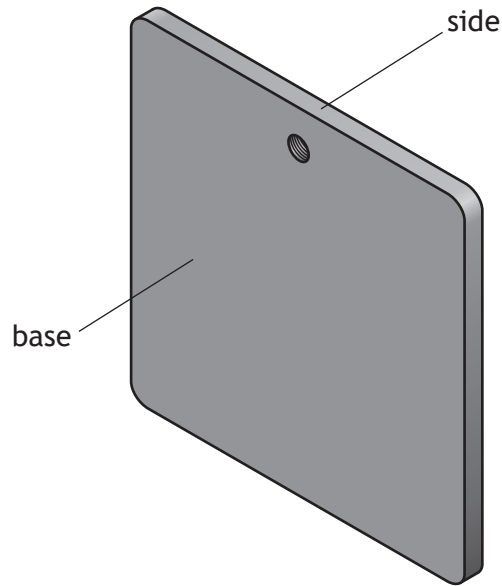

- (f) One stage in finishing the sides of the base is given below.
State three further stages.

3

Cross file

- 1 _____
- 2 _____
- 3 _____

1. (continued)

The machine shown below was used to manufacture the stem and the bolt.

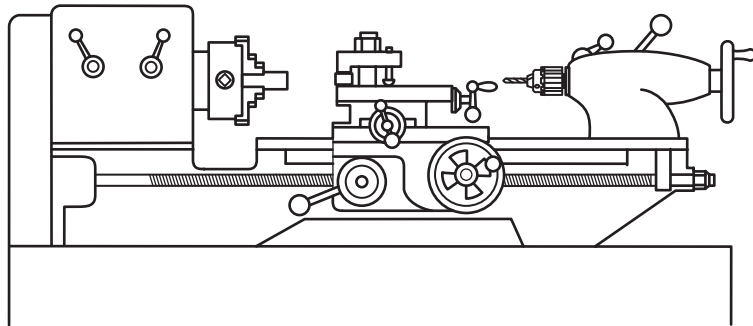

(g) Name the machine.

1

The parts of the machine that move the cutting tool are shown below.

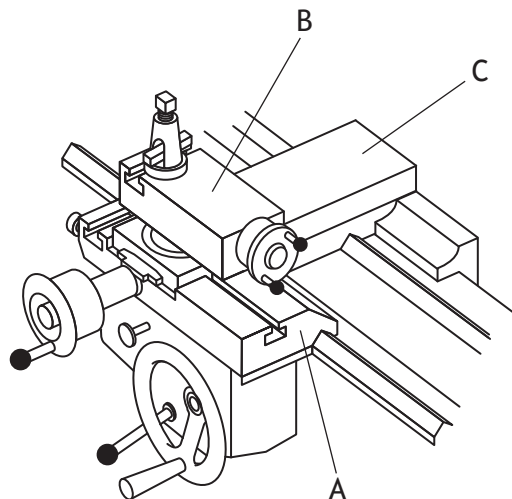

(h) Name parts A, B and C.

3

Part A _____

Part B _____

Part C _____

[Turn over



1. (continued)

A four jaw chuck and a three jaw chuck are shown below.

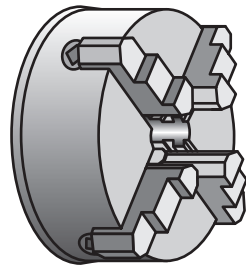

four jaw chuck

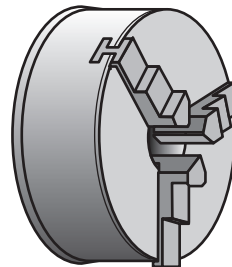

three jaw chuck

- (i) (i) Describe one advantage of using the four jaw chuck.

1

A common section that can be held centrally in a three jaw chuck is round bar.

- (ii) Name one other common section that can be held centrally in a three jaw chuck.

1

1. (continued)

A number of processes were used to manufacture the bolt, shown below.

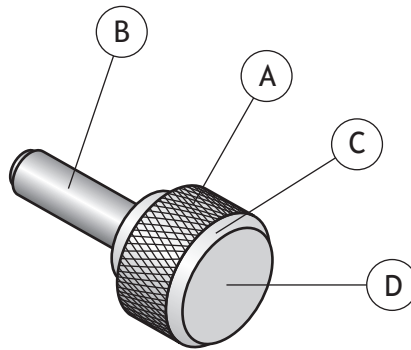

(j) Name each process.

3

Process A has been completed for you.

Process A Knurling _____

Process B _____

Process C _____

Process D _____

[Turn over



1. (continued)

The analogue micrometer, shown below, was used to check diameters during manufacture of the bolt.

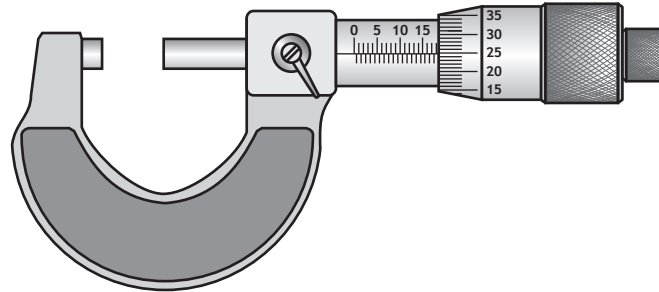

A reading from the analogue micrometer is shown below.

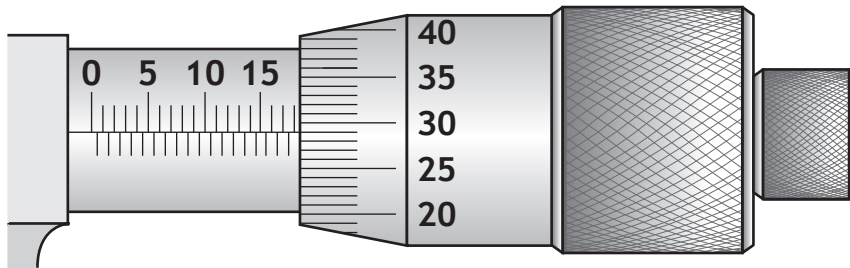

(k) (i) State the correct reading.

1

1. (k) (continued)

Readings from a digital micrometer are shown below.

The **diameter** of the bolt needs to be **12 mm** and the **tolerance** required is **+/- 0.2 mm**.

(ii) Identify the reading which is within tolerance, by ticking (✓) the correct box below.

1

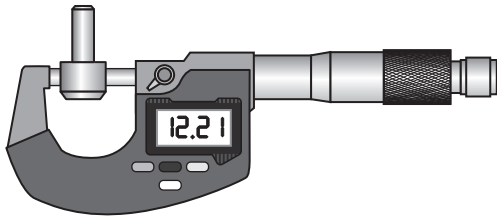

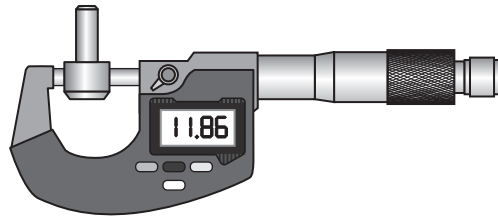

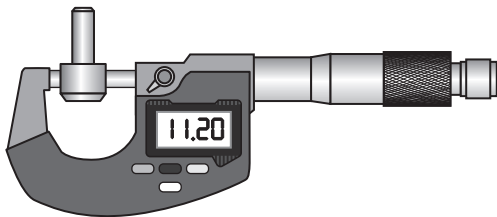

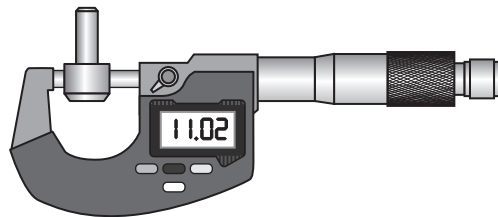

The diameters of the bolt are checked before threading and knurling.

(l) State the name of a tool, other than the digital or analogue micrometer, which would give an accurate measurement.

1

[Turn over

1. (continued)

The hole in the holder shown below was drilled using a 6.5 mm twist drill. When checking the size of hole, it was found that it was larger than 6.5 mm.



(m) State two possible reasons why the hole is too large.

2

1. (continued)

The machine shown below was used to remove the material from the holder.

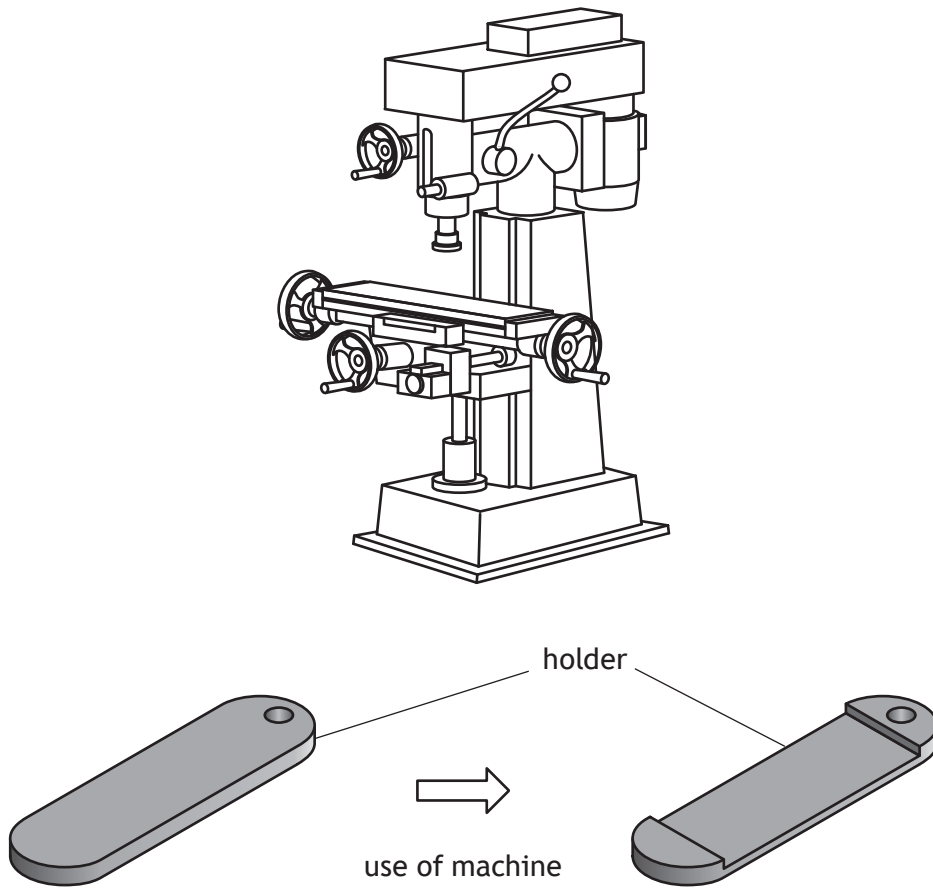

(n) Name this machine.

1

[Turn over

2. An aluminium sheet metal lamp is shown below.

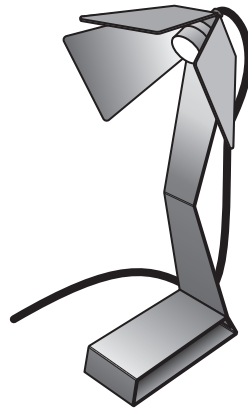

The lamp is marked out as shown below, and is made from a thin aluminium sheet.

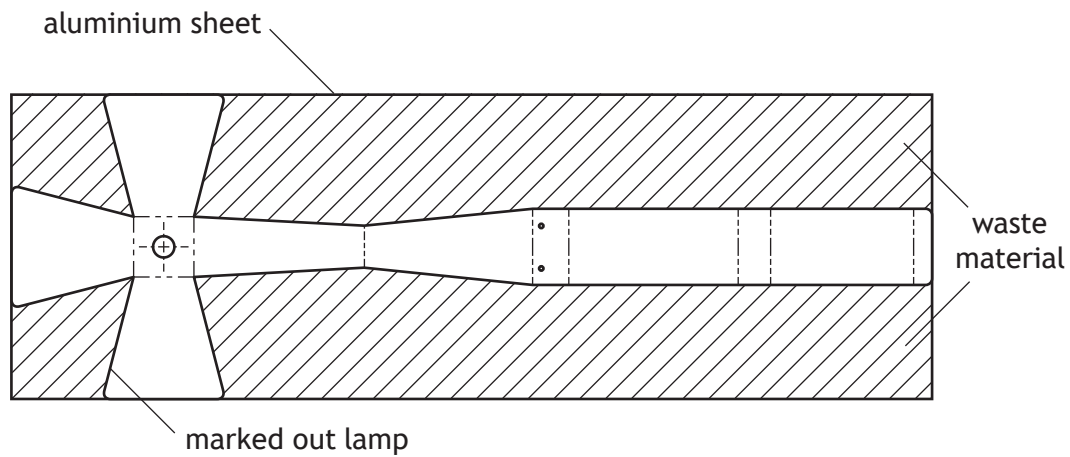

Two line types that can be used to complete working drawings are shown below.

- (a) (i) State the uses of the following line types:
a chain thin line

2

a continuous thick line.

2. (a) (continued)

- (ii) State the name of one piece of personal protective equipment that should be worn when handling sheet metal.

1

The steps shown in the table below are in the wrong order for preparing and marking out the lamp.

- (iii) Identify the correct order by completing the table below.

2

Steps	Enter the correct order
Mark out the lamp using the correct tools	3
Paint on engineer's blue	2
Create witness marks	
Clean the metal of any dirt and grease	

- (iv) Explain three safety checks that must be carried out on the pillar/ pedestal drill before drilling sheet metal.

3

[Turn over



2. (a) (continued)

Most of the waste material was cut away using a notcher.

(v) Identify the **notcher** by ticking (✓) the correct box below.

1

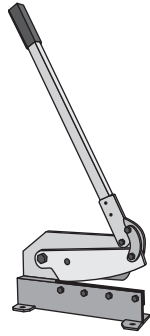

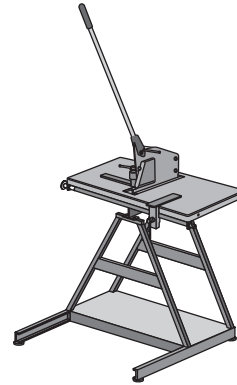

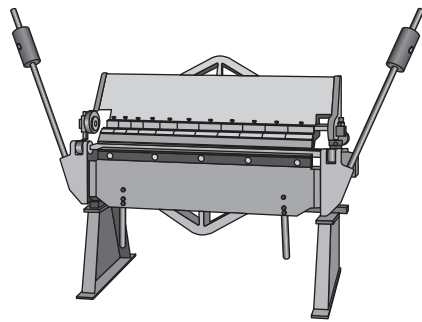

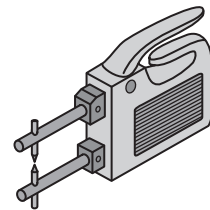

The hand tool shown below was used with a hide mallet to fold the lamp.

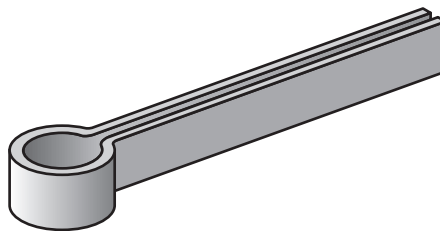

(b) Name this tool.

1

2. (continued)

(c) (i) Explain the purpose of annealing metal.

1

(ii) Explain why soap is rubbed onto the surface of aluminium during the annealing process.

1

The image below shows the base of the lamp being secured by riveting.

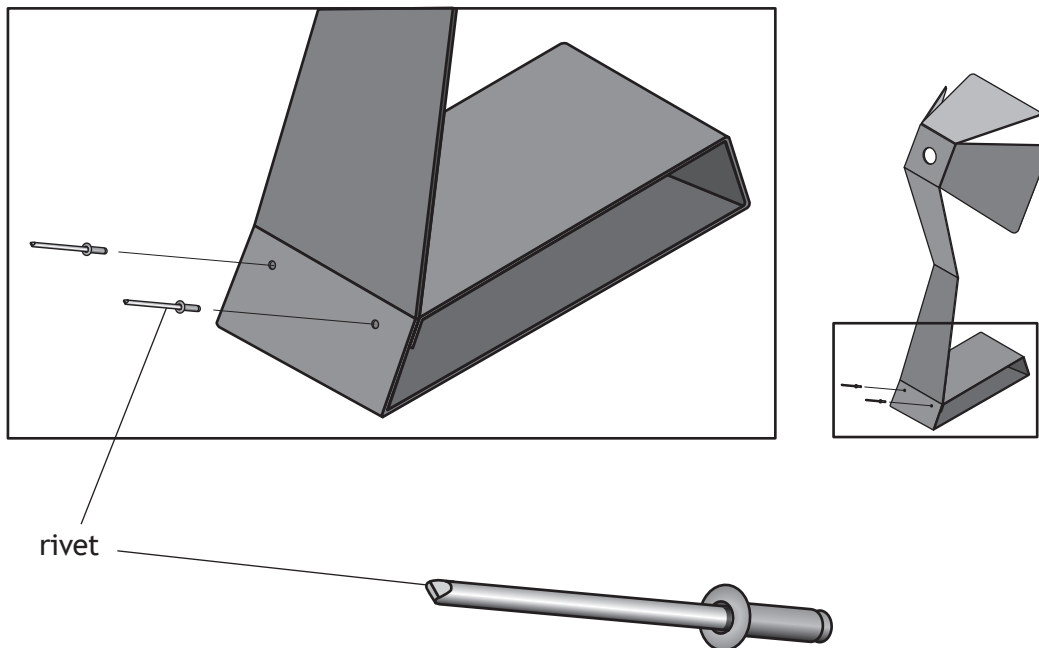

(d) (i) State the name of the rivet used in this process.

1

It is relatively quick and easy to use this type of rivet.

(ii) Explain one other reason why this type of rivet has been used to join the lamp.

1



2. (continued)

- (e) (i) Describe a simple test used to separate aluminium from mild steel as part of the recycling process.

1

- (ii) Explain two reasons why up-cycling aluminium benefits the environment.

2



3. A mild steel sundial made from two separate parts is shown below.

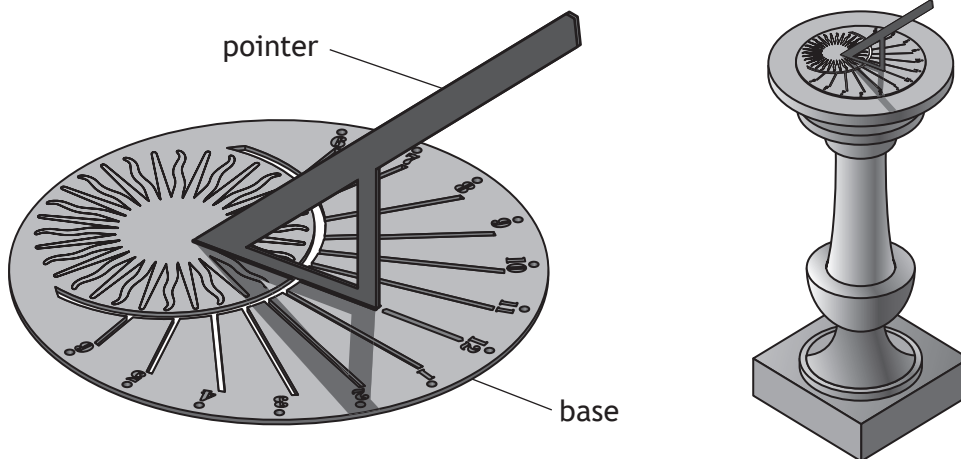

- (a) (i) Name an industrial process used to cut the shape of the base. 1

After industrial cutting processes, metal can become brittle.

- (ii) Name the heat treatment process that could be applied to the metal to reduce the brittleness. 1

[Turn over

3. (continued)

The machine shown below is used in the heat treatment process.

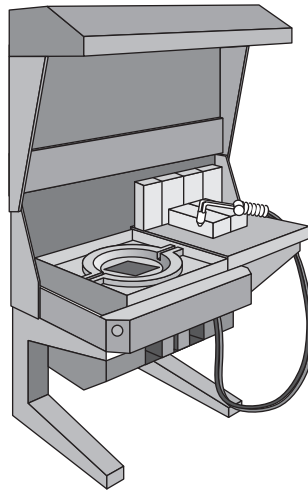

- (b) State three pieces of personal protective equipment that should be worn when using this machine.

3

3. (continued)

The two separate parts of the sundial will be attached together as shown below.

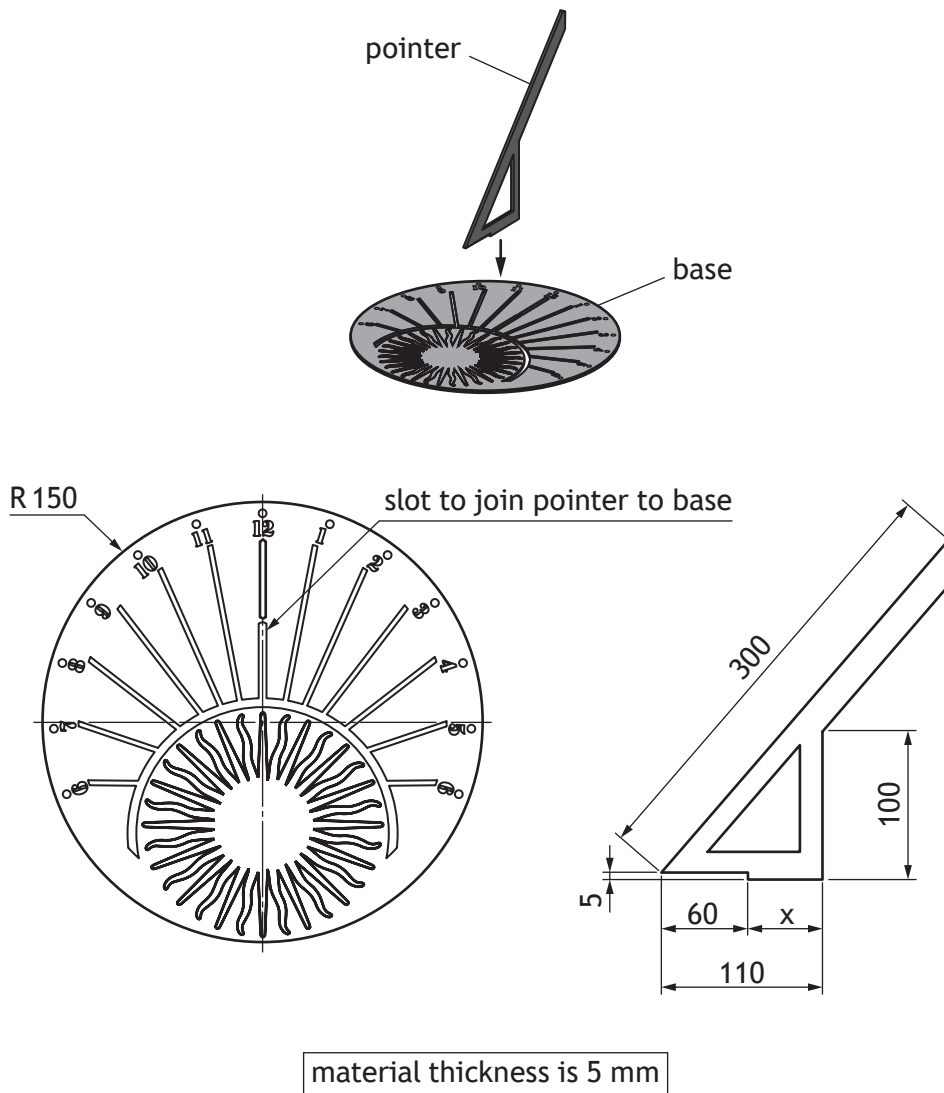

(c) Using the working drawings of the sundial above, calculate the following:

(i) the diameter of the sundial (base) 1

(ii) the length of dimension x 1

(iii) the minimum width of the slot required to join the pointer to the base. 1



3. (continued)

MARKS DO NOT WRITE IN THIS MARGIN

The two parts of the sundial will be welded together as shown below.

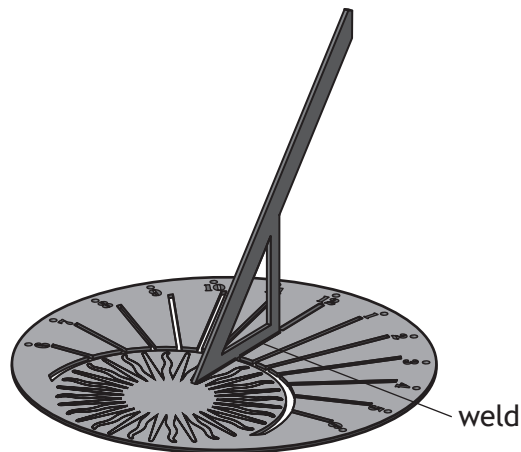

(d) State the name of a suitable welder which could be used to join the two parts. 1

The sundial is to be powder dip coated.

(e) Describe the process of powder dip coating. 3
You may use sketches to support your answer.

[END OF QUESTION PAPER]



MARKS DO NOT
WRITE IN
THIS
MARGIN

ADDITIONAL SPACE FOR ANSWERS



MARKS DO NOT
WRITE IN
THIS
MARGIN

ADDITIONAL SPACE FOR ANSWERS

