



National 5 Practical Metalworking

Practical activity

Parts and materials: garden lantern

Valid for sessions 2018-19, 2019-20, 2020-21, 2021-2022,
2022-2023, 2023-24 only.

The information in this publication may be reproduced in support of SQA qualifications only on a non-commercial basis. If it is reproduced, SQA must be clearly acknowledged as the source. If it is to be reproduced for any other purpose, written permission must be obtained from permissions@sqa.org.uk.

This edition: August 2022 (version 1.0)

© Scottish Qualifications Authority 2022

Contents

Introduction	1
Instructions for teachers and lecturers	2

Introduction

This document contains information for teachers and lecturers when preparing materials for candidates to use in the National 5 Practical Metalworking practical activity.

The National 5 Practical Metalworking Practical Activity course assessment is an annually issued task. It is published on the secure area of SQA's website at the end of October of each academic session and is only valid for that academic session.

To support centres (and to ease the planning of material purchases) we will use the same parts/materials list for five academic sessions. This document details the parts list and materials that will be used.

Instructions for teachers and lecturers

Simplified garden lantern

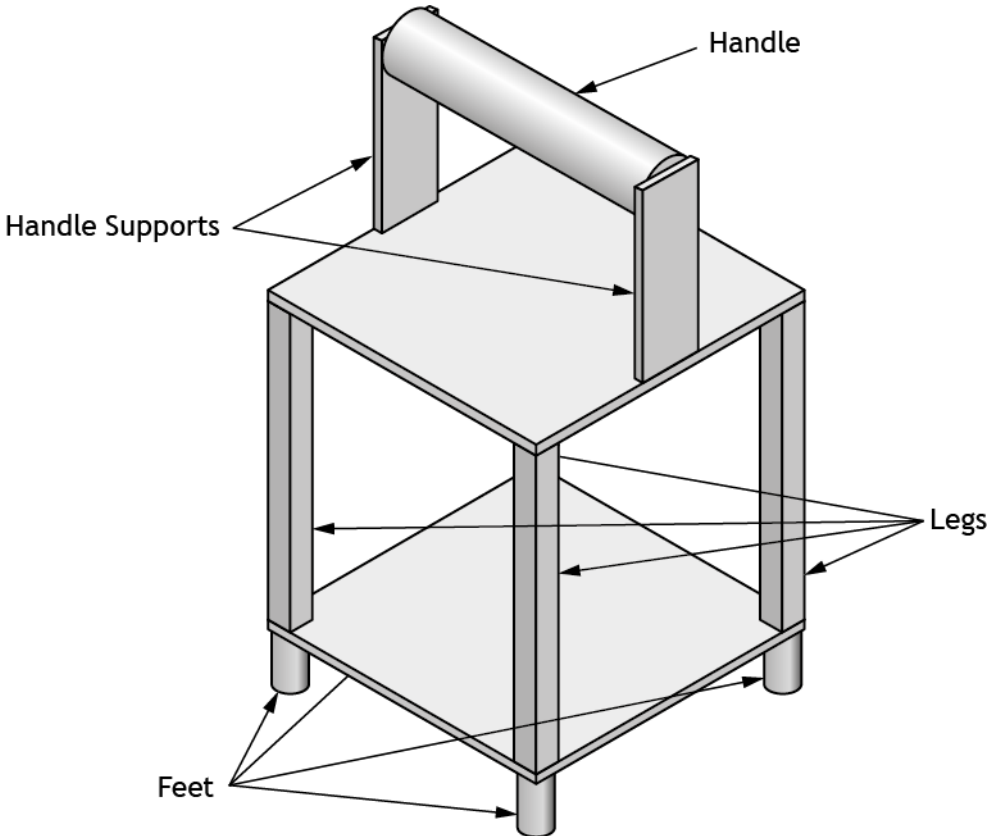

The garden lantern will also incorporate a sheet metal tray and an air vent.

For the next five academic sessions, the practical activity will be the ‘garden lantern’ using the parts/materials detailed in this document. However, the annually issued practical activity document will have specific details that candidates must follow. This may be a particular join at a given point, a specific shape template, or something similar.

The sizes given below indicate the maximum finished size of component parts.

Parts/materials list

Part	Description	Quantity	Material	Length	Breadth	Thickness
A	Base	1	Mild steel	100	100	3
B	Lid	1	Mild steel	100	100	3
C	Square leg (Option 1)	4	Metal ¹	100	8	8
D	Round leg (Option 2)	4	Metal ¹	100	-	Ø8
E	Handle support	2	Mild steel	80	20	3
F	Handle	1	Metal ¹	100	-	Ø20
G	Foot	4	Metal ¹	35	-	Ø10
H	Air vent	1	Mild steel	130	30	0.5
I	Tray	1	Mild steel	90	90	0.5
J	M5x20 Screw (supplied)	6				
K	Rivet	As required				

Note: All sizes are in mm

¹ Centres are free to choose any metal for the identified parts.

Either **Part C** or **Part D** are required to manufacture the garden lantern.

Please note the following:

The practical activity must not be altered, adapted or modified in any way. This includes moving the content into a different format or re-drawing and/or producing additional working drawings.

Centres must not alter lengths or widths. Centres should not alter thicknesses. However, where centres cannot source a metal plate material thickness, they can substitute material of the closest available thickness. Any change to thickness must not impact on the validity of assessment or the functionality of the project. If a thickness is changed, the centre **must** adjust the working drawings to reflect this change. Any change must not impact on the validity of assessment or the functionality of the project. The amended drawings must be in identical format and layout to SQA-issued drawings.

Administrative information

Published: August 2022 (version 1.0)

History of changes

Version	Description of change	Date

Security and confidentiality

This document can be used by practitioners in SQA approved centres for the assessment of National Courses and not for any other purpose.

© Scottish Qualifications Authority 2022