



FOR OFFICIAL USE

|  |  |  |  |  |  |
|--|--|--|--|--|--|
|  |  |  |  |  |  |
|--|--|--|--|--|--|

National  
Qualifications  
2021 ASSESSMENT RESOURCE

Mark

|  |
|--|
|  |
|--|

**X844/75/02**

# Applications of Mathematics Paper 2

Duration — 2 hours



Fill in these boxes and read what is printed below.

Full name of centre

|  |
|--|
|  |
|--|

Town

|  |
|--|
|  |
|--|

Forename(s)

|  |
|--|
|  |
|--|

Surname

|  |
|--|
|  |
|--|

Number of seat

|  |
|--|
|  |
|--|

Date of birth

Day

|  |  |
|--|--|
|  |  |
|--|--|

Month

|  |  |
|--|--|
|  |  |
|--|--|

Year

|  |  |
|--|--|
|  |  |
|--|--|

Scottish candidate number

|  |  |  |  |  |  |  |  |  |  |
|--|--|--|--|--|--|--|--|--|--|
|  |  |  |  |  |  |  |  |  |  |
|--|--|--|--|--|--|--|--|--|--|

**Total marks — 65**

Attempt ALL questions.

**You may use a calculator.**

To earn full marks you must show your working in your answers.

State the units for your answer where appropriate.

Write your answers clearly in the spaces provided in this booklet. Additional space for answers is provided at the end of this booklet. If you use this space you must clearly identify the question number you are attempting.

Use **blue** or **black** ink.

Before leaving the examination room you must give this booklet to the Invigilator; if you do not, you may lose all the marks for this paper.



## FORMULAE LIST

Circumference of a circle  $C = \pi d$

Area of a circle  $A = \pi r^2$

Theorem of Pythagoras

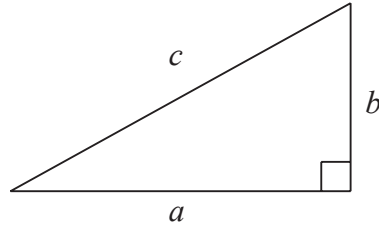

$$a^2 + b^2 = c^2$$

Volume of a cylinder  $V = \pi r^2 h$

Volume of a prism  $V = Ah$

Volume of a cone  $V = \frac{1}{3} \pi r^2 h$

Volume of a sphere  $V = \frac{4}{3} \pi r^3$

Standard deviation  $s = \sqrt{\frac{\sum (x - \bar{x})^2}{n - 1}}$

or  $s = \sqrt{\frac{\sum x^2 - \frac{(\sum x)^2}{n}}{n - 1}}$ , where  $n$  is the sample size.

Gradient

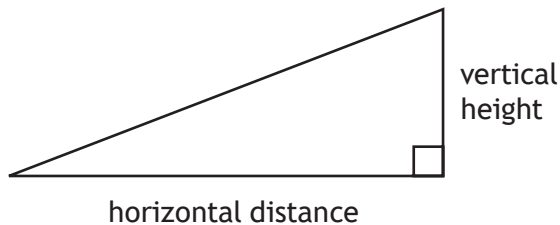

$$\text{gradient} = \frac{\text{vertical height}}{\text{horizontal distance}}$$



Total marks — 65  
Attempt ALL questions

1. Omar has £3000 which he will invest for 3 years.  
He is considering two options.

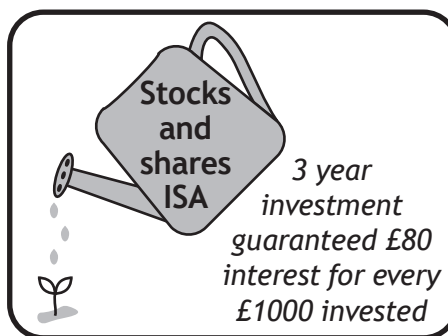
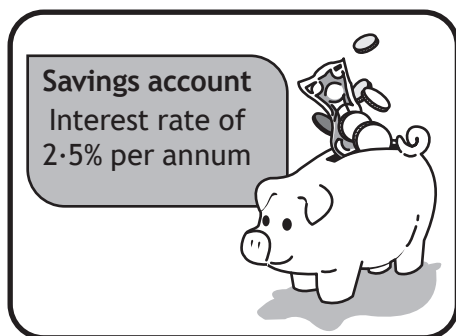

Determine which option will have the greater value after 3 years.  
Use your working to justify your answer.

4



2. A property developer has the garden plans for a new housing project.

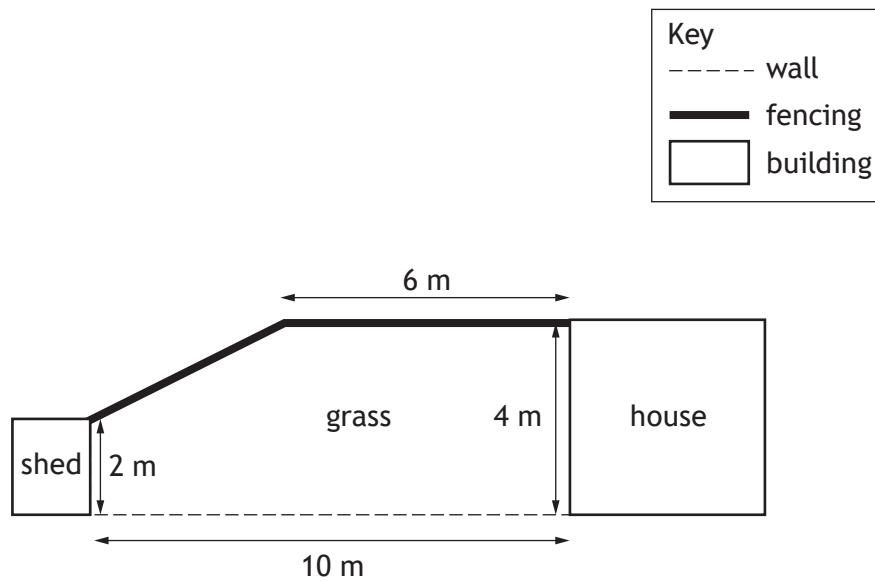

The fencing is at a right angle to the house.

The wall is at a right angle to the house and the shed.

Fencing panels are sold in 2 m sections costing £21·40 each.

- (a) Calculate the minimum cost of buying fencing.

5

- (b) Calculate the area of the grass.

2



\* X 8 4 4 7 5 0 2 0 4 \*

3. Ben went to Canada and then to the United States of America.  
The exchange rates were

| Currency exchange |                       |
|-------------------|-----------------------|
| Pounds sterling   | Other currencies      |
| 1                 | 1.75 Canadian dollars |
| 1                 | 1.31 US dollars       |

- Ben changed £900 into Canadian dollars.
- He spent 945 Canadian dollars during his stay in Canada.
- He changed his remaining Canadian dollars into US dollars.

Calculate how many US dollars he received.

3



4. Colin is spreading a layer of bark in part of his garden.  
The area of the garden that Colin is covering in bark is shaded in the diagram.

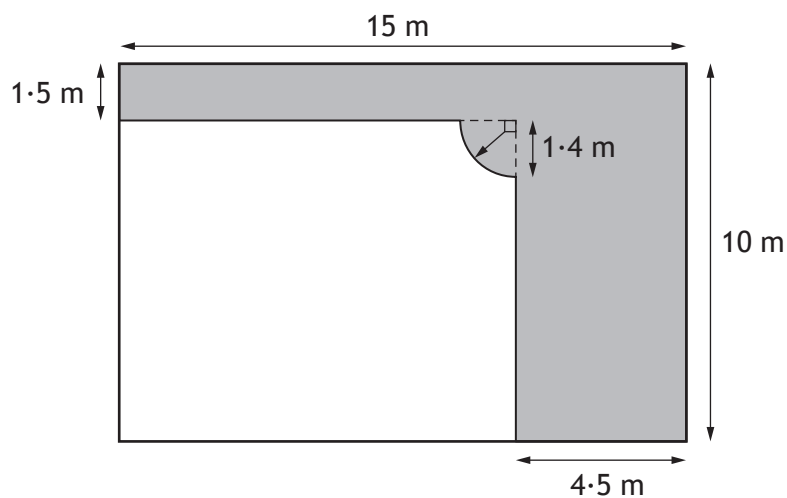

The layer of bark needs to be 50 millimetres deep.

- (a) Calculate the volume of bark needed.  
Give your answer in litres.

5



4. (continued)

Ameena is also spreading a layer of bark in her garden.

She needs to buy 6300 litres of bark.

She has a choice of three brands.

All the bark she buys will be the same brand.

| Brand A  | Brand B               | Brand C  |
|--|-----------------------|--|
| 100 litres bag @ £6.99<br>Special Offer<br>Two bags for £11.99 | 90 litres bag @ £5.99 | 70 litres bag @ £4.79<br>Special Offer<br>Buy two bags get the<br>third bag free |

- (b) Determine which brand offers the cheapest price for Ameena to buy her bark.

3



5. Paula's annual salary is £54 890.

National insurance is calculated on a person's salary **before** deductions such as pension contributions.

| Annual national insurance rates |     |
|---------------------------------|-----|
| Up to £8632                     | 0%  |
| From £8632 to £50 000           | 12% |
| Over £50 000                    | 2%  |

(a) Calculate Paula's annual national insurance payment.

3

Paula pays 8.7% of her annual salary into her pension.

Her annual income tax is £8204.37.

She is paid in 52 weekly payments.

(b) Calculate Paula's weekly net pay.

2





6. Finlay travelled from his home to work, 23.1 miles away.  
 His average speed was 42 mph.  
 He left his home at 08:12.

(a) Calculate what time he arrived at work.

2

At the weekend, Finlay plans to make a **return** journey from his home to the shopping centre.

He knows

- the shopping centre is 26 miles away
- his car will cover an average of 67 km per gallon of fuel
- the car has 5 litres of fuel in its tank.

(b) Determine if Finlay will have enough fuel to complete this **return** journey.

1 mile = 1.609 km

1 gallon = 4.545 litres

4



\* X 8 4 4 7 5 0 2 0 9 \*

7. Dougie is organising a birthday party for his son.  
 There will be 13 children at the party.  
 He will give them juice in cups that are cylindrical with dimensions as shown.

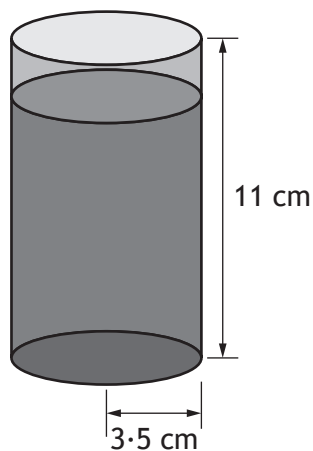

- Each cup will be filled with juice to 2 cm from the top.
- He will give each child 2 cups of juice.
- He will buy the juice in bottles which each contain 1.75 litres.

(a) Calculate the number of bottles of juice he will need to buy.

4



## 7. (continued)

He plans to buy circular pizzas from his local takeaway.

He considers two options.

- A pizza with a diameter of 10 inches costs £4.
- A pizza with a diameter of 12 inches costs £5.30.

Both pizzas have the same uniform depth.

(b) (i) Calculate the area of both pizzas.

1

(ii) Hence calculate which size of pizza is better value per square inch.

3



\* X 8 4 4 7 5 0 2 1 1 \*

## 7. (continued)

MARKS  
DO NOT  
WRITE IN  
THIS  
MARGIN

Dougie wants to hire the local soft play centre with a DJ for the party.  
The table below shows the price per child per hour.

| Number of children | Soft play only | Soft play and party bag | Soft play and food | Soft play and DJ | Soft play, food and DJ |
|--------------------|----------------|-------------------------|--------------------|------------------|------------------------|
| 1-5                | £3             | £4                      | £5                 | £6               | £6.50                  |
| 6-10               | £2.70          | £3.50                   | £4.50              | £5.50            | £6                     |
| 11-15              | £2.55          | £3.20                   | £4.20              | £5.20            | £5.70                  |
| 16-20              | £2.40          | £3                      | £4                 | £5               | £5.50                  |
| Over 20            | £2.20          | £2.75                   | £3.80              | £4.80            | £5.30                  |

The party will start at 4 pm and end at 6 pm.

(c) Calculate the total cost for the 13 children for soft play and DJ.

2

8. A local primary school is having a summer event.

They plan to make shortbread to sell at the event.

- They make 10 trays of shortbread.
- Each tray contains 24 slices of shortbread.
- The total cost to make 10 trays of shortbread is £38.20.

The school want to make a profit of at least £20 from the sale of this shortbread.

(a) Calculate the minimum price that the school should charge for one slice of shortbread.

2



\* X 8 4 4 7 5 0 2 1 2 \*

8. (continued)

The local orienteering club set up a course at the event.

- Participants leave the start point and run on a bearing of  $055^\circ$  for 140 m to flag A.
- They then run on a bearing of  $170^\circ$  for 252 m to flag B.

(b) (i) Construct a scale drawing to illustrate the route.

3

Use a scale of 1 cm : 40 m

(An additional diagram, if required, can be found on *page 18*)



(ii) The pupils then return to the start point.

Use the scale drawing to determine the bearing and distance of the start point from flag B.

2



## 8. (continued)

Two of the games at the event are a lucky dip and a dice game.

The lucky dip has tickets numbered 1 to 150.

To win a prize the ticket needs to end in a zero or a five.

The dice game involves rolling two dice at the same time.

To win a prize a total of **9 or more** is needed.

- (c) Determine which game has the higher probability of a prize being won. 4



9. A company uses a packing machine to put sweets into packets.  
 The number of sweets in a sample of packets is counted.  
 The number of sweets in each packet is shown below.

39    39    42    41    43    36

(a) Calculate

(i) the mean

1

(ii) the standard deviation.

3

The company purchase a new packing machine.

The number of sweets in a sample of packets from the new machine is counted.

For the new machine the mean number of sweets is 40 and the standard deviation is 1.7.

(b) Make **two** valid comparisons about the number of sweets in each packet between the original and new machines.

2



9. (continued)

The packets are in the shape of a cuboid with external dimensions as shown.

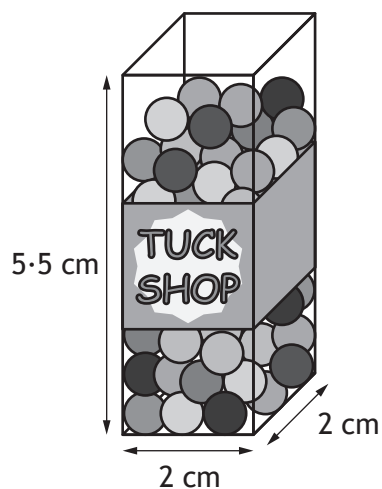

For delivery, the packets of sweets are packed into a box with internal dimensions as shown.

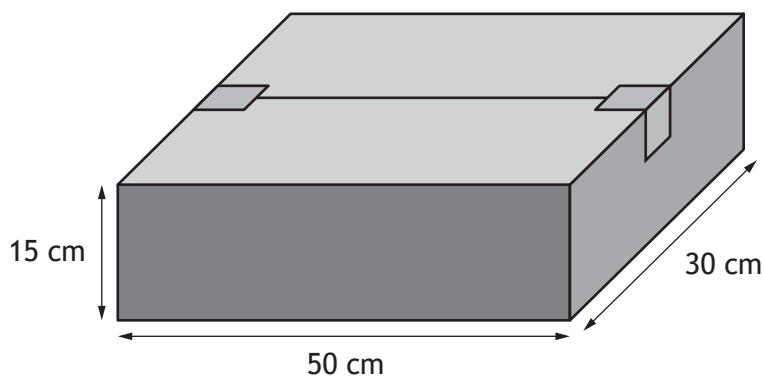

All the packets must be aligned in the same direction.

(c) Calculate the maximum number of packets that can fit in the box.

3





## 9. (continued)

In each packet there are seven colours.

The table shows the number of each colour present in each packet.

| Colour | yellow | purple | pink | red | blue | green | orange |
|--------|--------|--------|------|-----|------|-------|--------|
| Number | 7      | 8      | 6    | 4   | 4    | 3     | 7      |

The packets must be filled as shown in the table.

There are 27 500 of **each** colour in stock.

(d) Calculate how many packets can be filled.

2

[END OF QUESTION PAPER]



\* X 8 4 4 7 5 0 2 1 7 \*

MARKS

DO NOT  
WRITE IN  
THIS  
MARGIN

ADDITIONAL SPACE FOR ANSWERS

Additional diagram for use in question 8 (b)



MARKS

DO NOT  
WRITE IN  
THIS  
MARGIN

ADDITIONAL SPACE FOR ANSWERS



\* X 8 4 4 7 5 0 2 1 9 \*

[BLANK PAGE]

DO NOT WRITE ON THIS PAGE



\* X 8 4 4 7 5 0 2 2 0 \*