

FOR OFFICIAL USE



National
Qualifications
2023 MODIFIED

Mark

X835/75/01

Graphic Communication

THURSDAY, 11 MAY

1:00 PM – 2:30 PM



* X 8 3 5 7 5 0 1 *

Fill in these boxes and read what is printed below.

Full name of centre

Town

Forename(s)

Surname

Number of seat

Date of birth

Day

Month

Year

Scottish candidate number

Total marks — 65

Attempt ALL questions.

All dimensions are in mm.

All technical sketches and drawings use third angle projection.

You may use rulers, compasses or trammels for measuring.

In all questions you may use sketches and annotations to support your answer if you wish.

Write your answers clearly in the spaces provided in this booklet. Additional space for answers is provided at the end of this booklet. If you use this space you must clearly identify the question number you are attempting.

Use **blue** or **black** ink.

Before leaving the examination room you must give this booklet to the Invigilator; if you do not, you may lose all the marks for this paper.



* X 8 3 5 7 5 0 1 0 1 *

Total marks — 65
Attempt ALL questions

1. 3D CAD illustrations and an exploded line drawing of a table lamp are shown below.

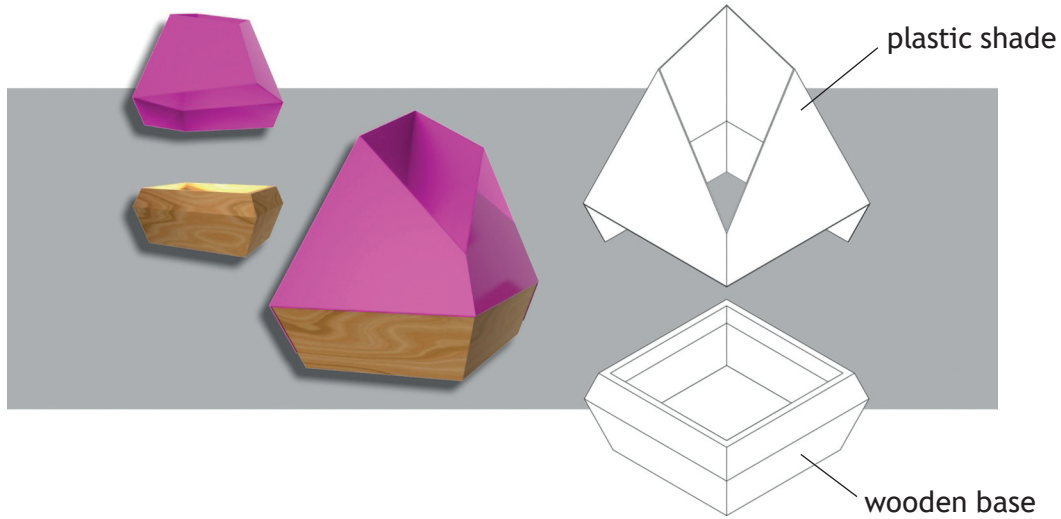

The table lamp has a plastic shade with two flaps that fold over a wooden base. These can be seen on the orthographic views of the table lamp below.

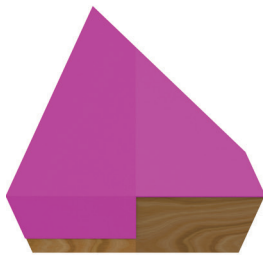

END ELEVATION

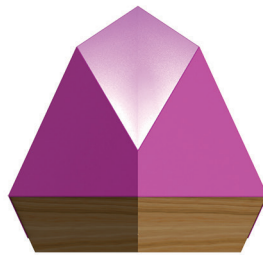

ELEVATION

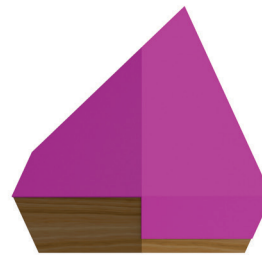

END ELEVATION



1. (continued)

- (a) An incomplete surface development of the plastic shade is shown below. Identify where the two flaps will be positioned on the surface development by ticking (✓) two boxes below.

2

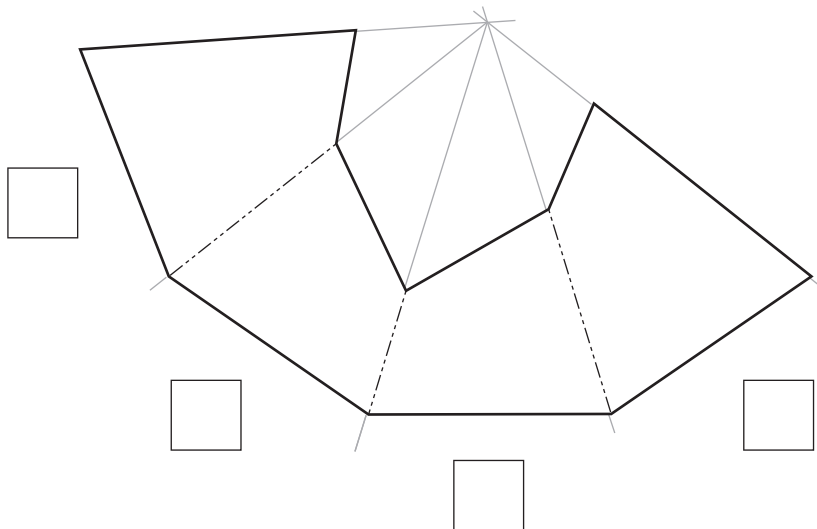

[Turn over

1. (continued)

MARKS DO NOT WRITE IN THIS MARGIN

Incomplete orthographic views of the plastic shade are shown below.

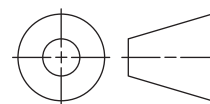
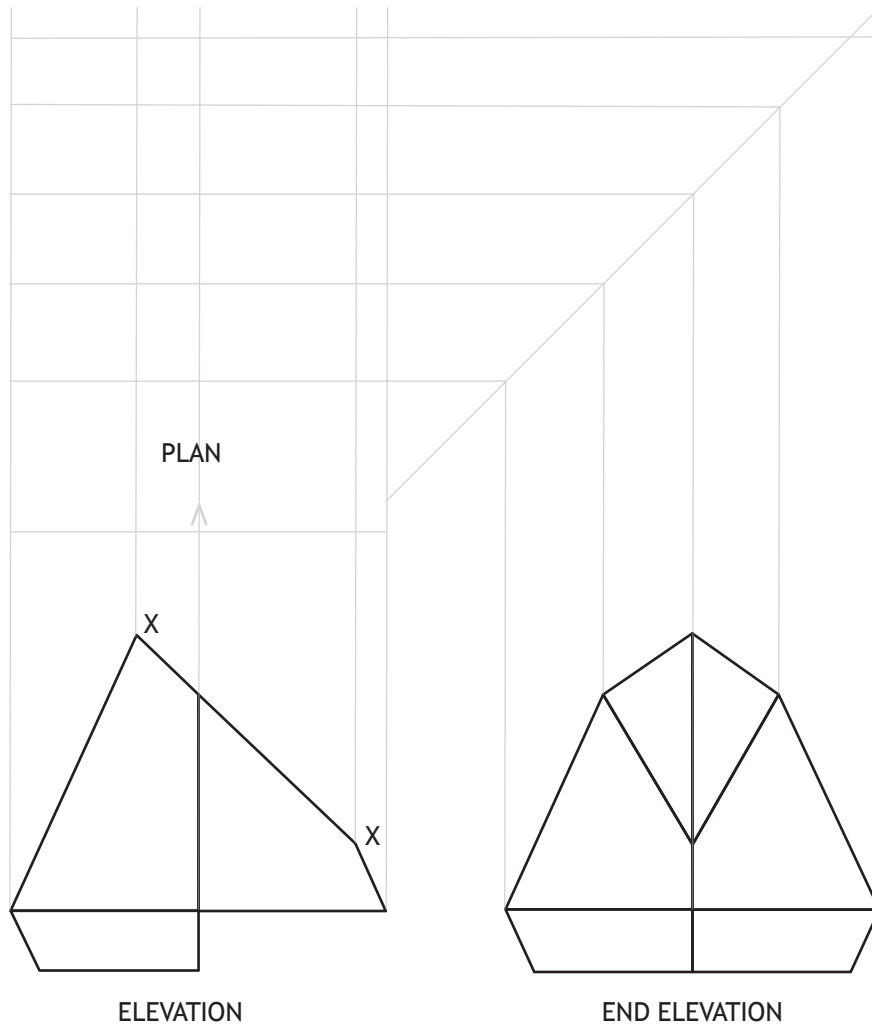

(b) Identify the correct true shape of X-X by ticking (✓) a box below. Use a ruler, compasses or trammel to measure.

1

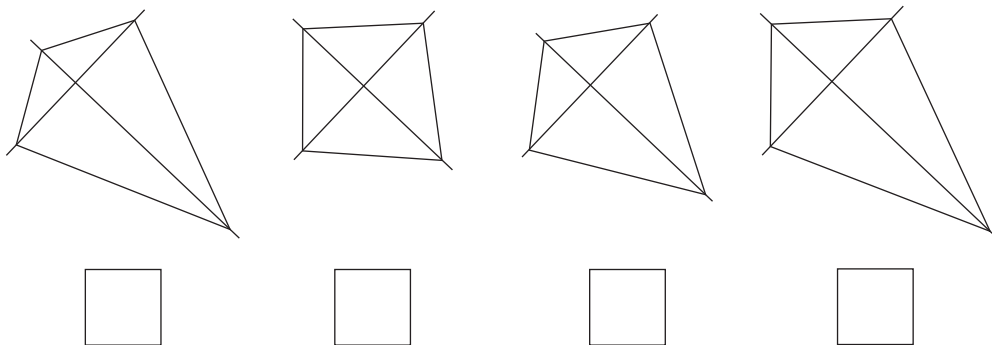

1. (continued)

(c) Identify the correct plan by ticking (✓) a box below. Use a ruler, compasses or trammel to measure.

1

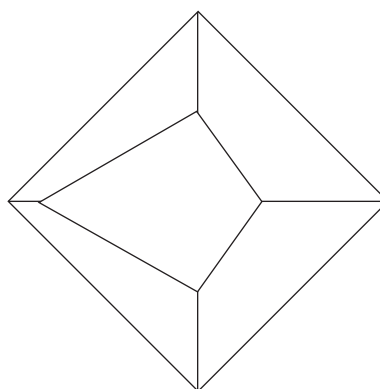
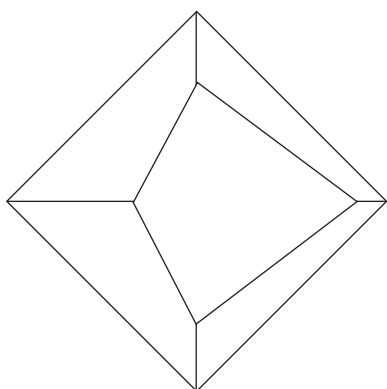
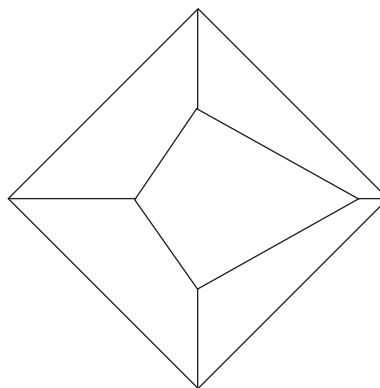
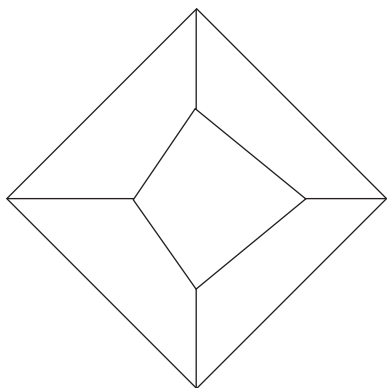

[Turn over

1. (continued)

Additional features are added to the original base design. Isometric line drawings of the original base and final base are shown below.

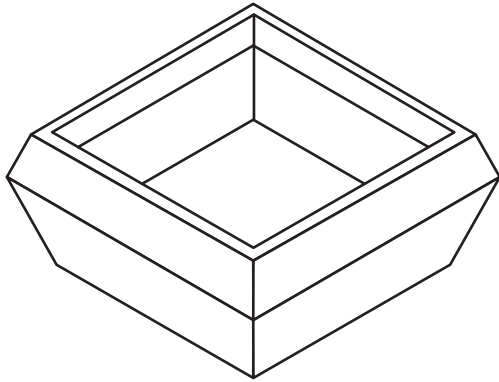

original base

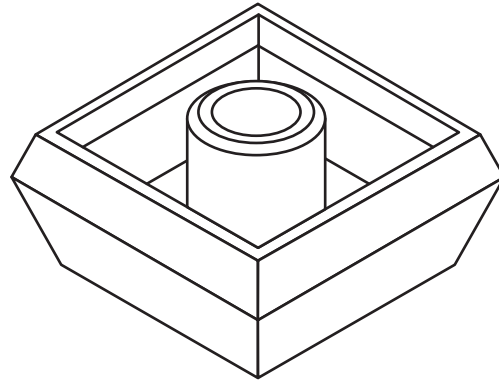

final base

An elevation and sectional end elevation of the final base are shown below.

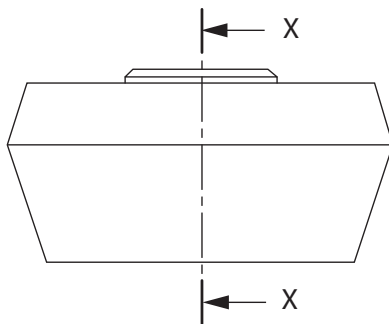

ELEVATION

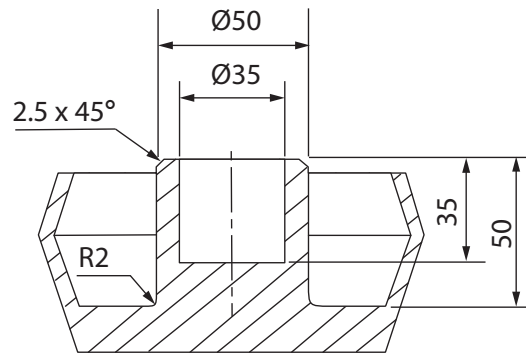

SECTION X-X

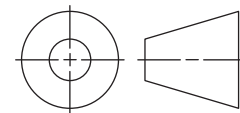

* X 8 3 5 7 5 0 1 0 6 *

1. (continued)

- (d) Describe, using the correct dimensions and 3D CAD modelling terms, how you would use 3D CAD software to model the additional features onto the original base. You may use sketches to support your answer.

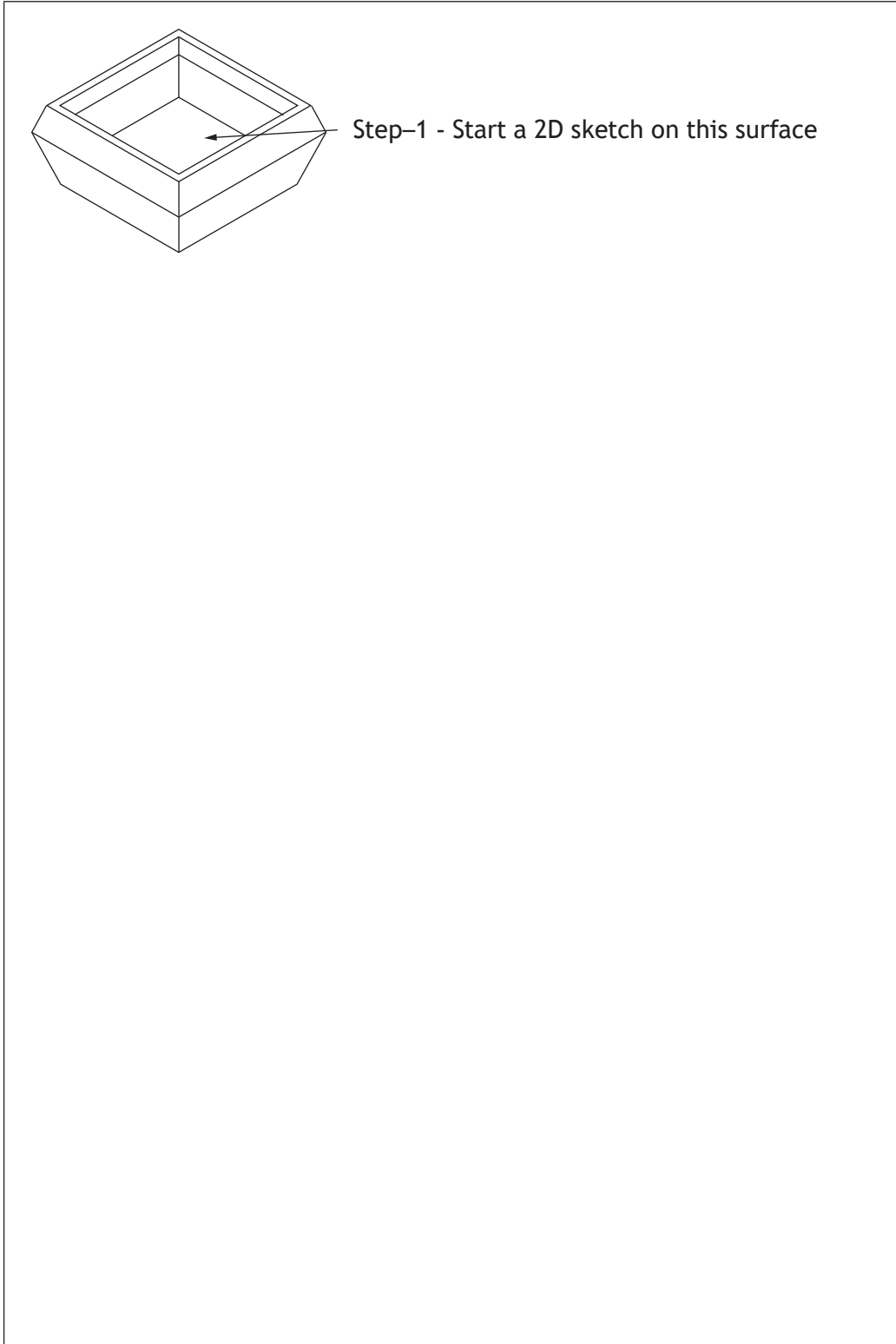

1. (continued)

A 2D logo is added to the bottom of the base.

To create the logo a number of 2D CAD drawing tools were used.

(e) State the name of the single CAD drawing tool used at each stage.

5

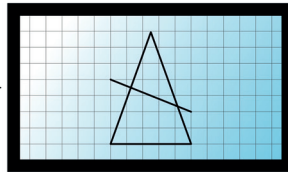
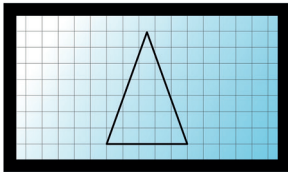

(i) Tool used

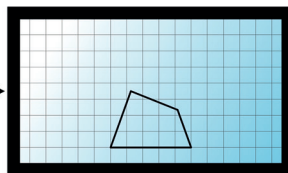
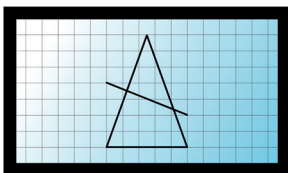

(ii) Tool used

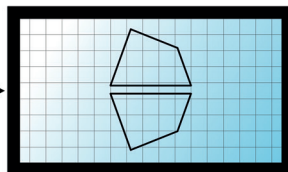
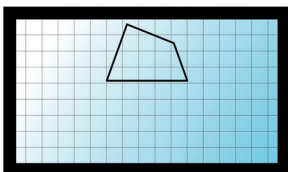

(iii) Tool used

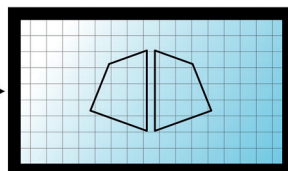
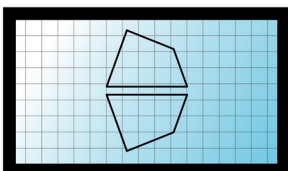

(iv) Tool used

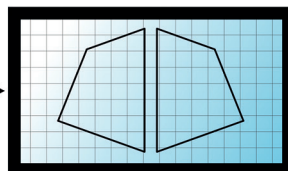
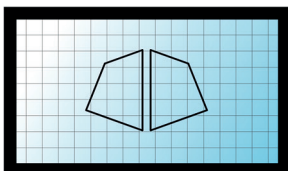

(v) Tool used

1. (continued)

A mobile app with graphic icons will be used to control the table lamp.

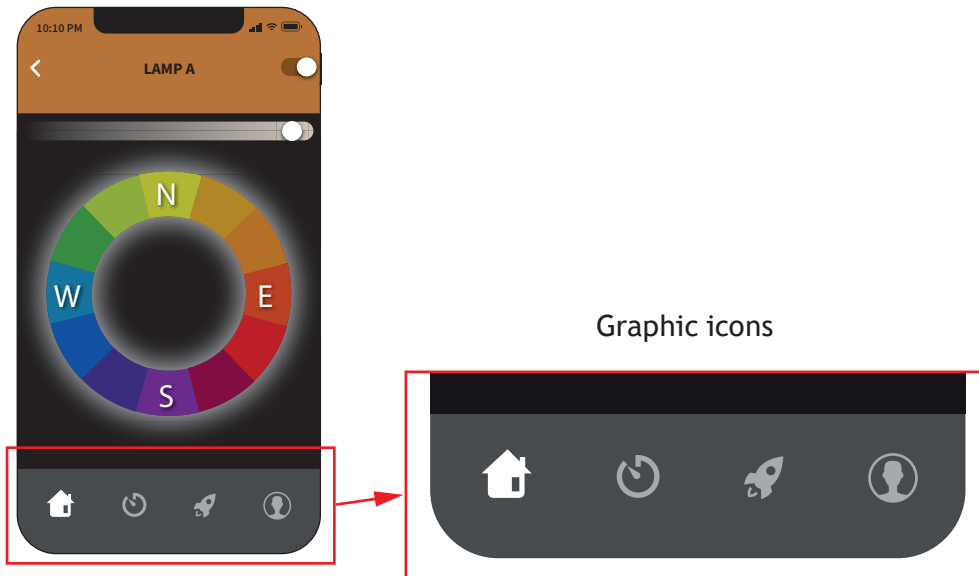

(f) Explain **two** reasons why graphic icons will be used for the mobile app.

2

[Turn over

2. A graphic designer had been asked to produce layouts for a company. During the preliminary design process several thumbnails were produced.

Thumbnail 1

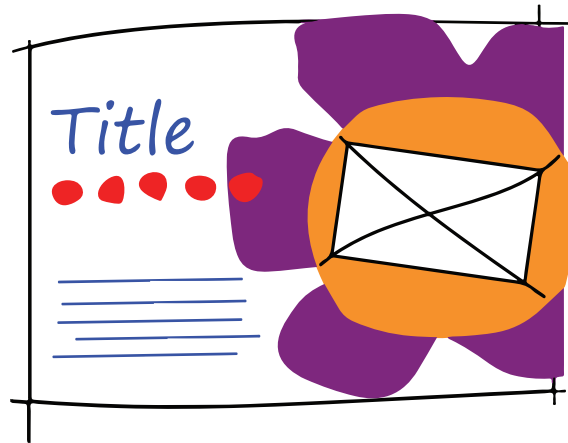

- (a) (i) Explain, referring to design elements or principles, why an orange circle has been placed behind the rectangular image in thumbnail 1.

1

2. (a) (continued)

MARKS DO NOT WRITE IN THIS MARGIN

Thumbnail 2

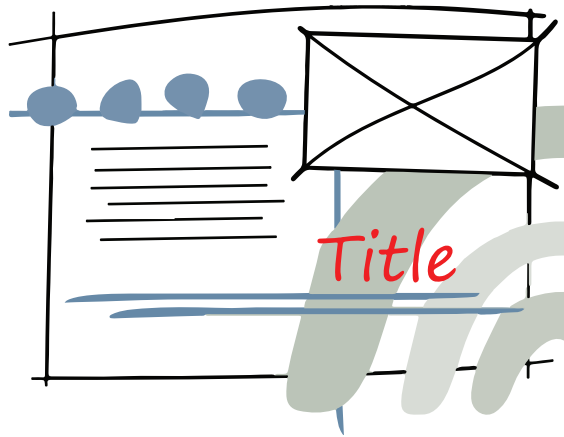

- (ii) Explain, referring to design elements or principles, why red has been used for the title in thumbnail 2. You must use a different response than in part 2 (a) (i).

1

Thumbnail 3

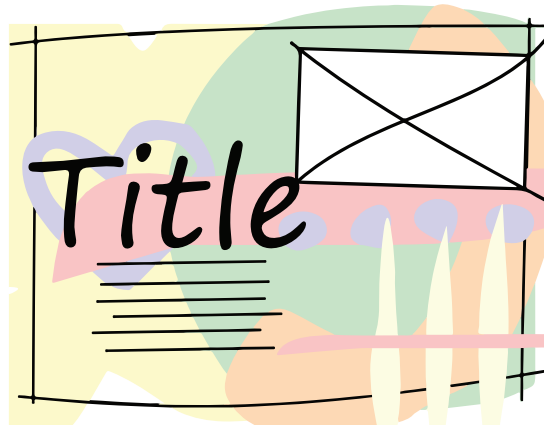

- (iii) Explain, referring to design elements or principles, why the title is large in thumbnail 3. You must use a different response than in part 2 (a) (i) and (ii).

1

- (b) Explain **one** advantage to the graphic designer of producing thumbnails.

1



2. (continued)

A layout is shown below.

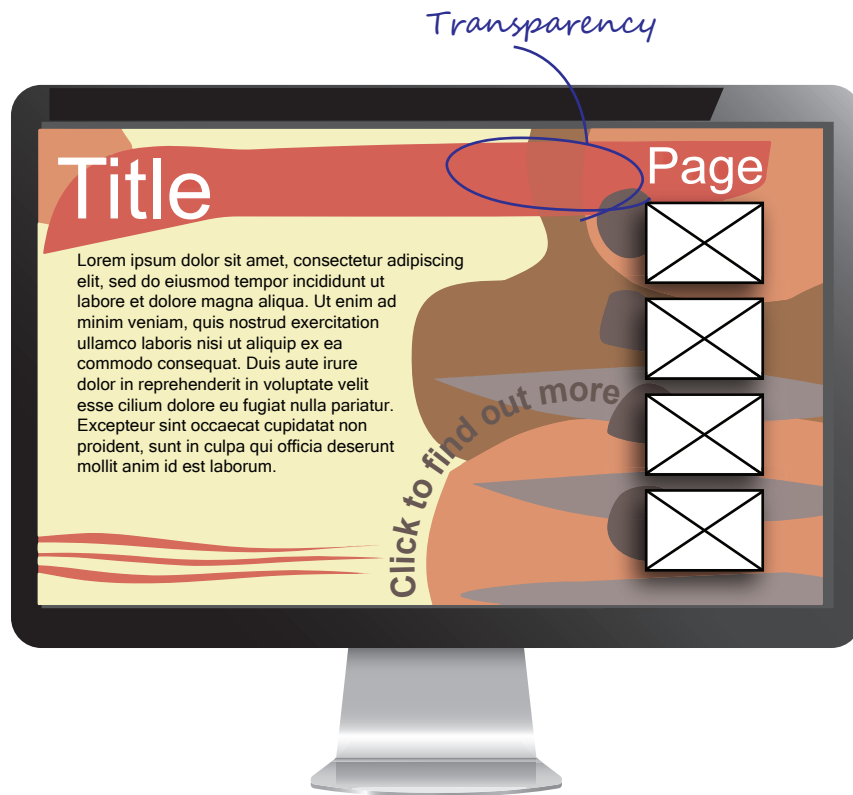

(c) Identify by circling and labelling the layout above where the following desktop publishing techniques have been used. An example has been provided for transparency.

4

- (i) Text wrap
- (ii) Reverse
- (iii) Drop shadow
- (iv) Flow text along a path

(d) Describe **two** ways alignment has been created in the layout above.

2

2. (continued)

The company asked for various options in both page orientation and paper sizing for graphic materials that will be printed.

(e) (i) Identify the portrait page orientation below by ticking (✓) a box below. 1





(ii) The layouts must be supplied in a range of paper sizes.

Explain the relationship between A4 and A3 paper sizes. 1

[Turn over

2. (continued)

The company have concerns about the environmental impact of their business and many of their employees are now working remotely from home.

- (f) (i) Describe **one** advantage that remote working will have on reducing the company's environmental impact.

1

- (ii) Describe **two** ways the company could reduce the environmental impact of their printed graphic materials.

2



[Turn over for next question

DO NOT WRITE ON THIS PAGE



* X 8 3 5 7 5 0 1 1 5 *

3. An orthographic drawing of a self-assembly television stand, with hidden detail, is shown below.

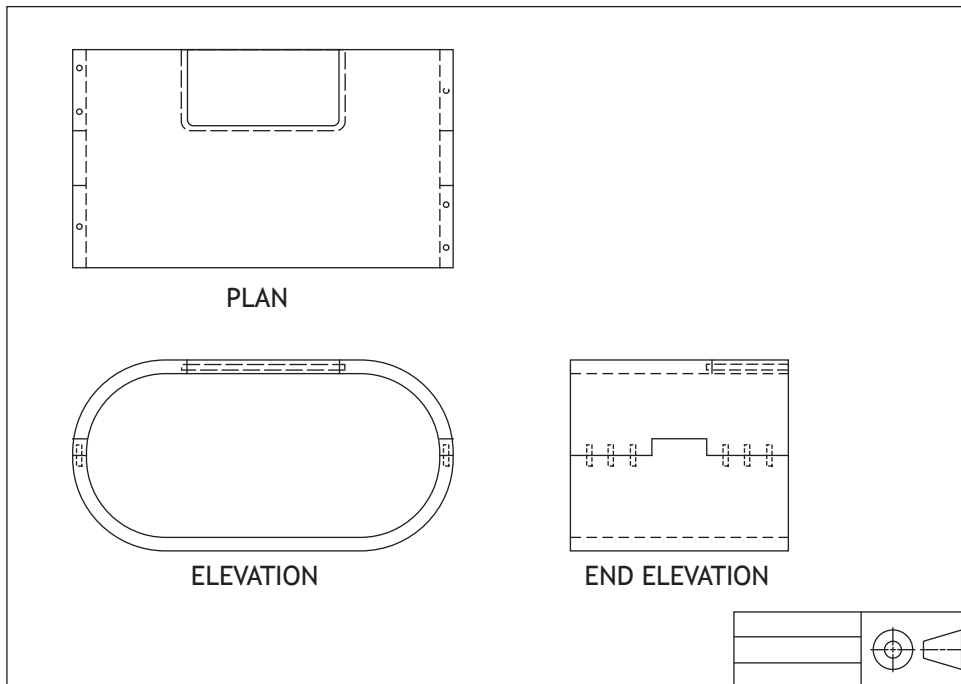

(a) Explain how orthographic drawings are used in manufacturing.

1

(b) A pictorial view of the television stand is shown below.

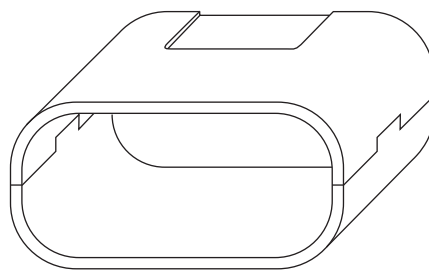

State the type of pictorial view.

1

3. (continued)

An exploded pictorial will be used to help the manufacturer understand how all the parts are assembled.

(c) Identify the correct exploded pictorial view by ticking (✓) a box below.

1

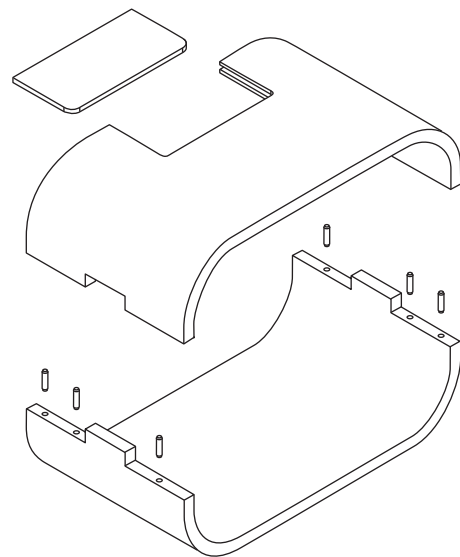

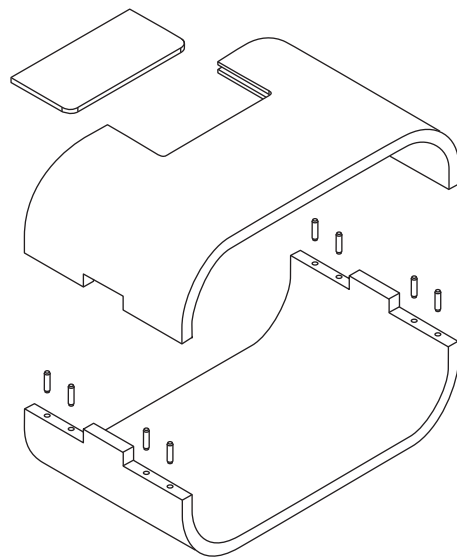

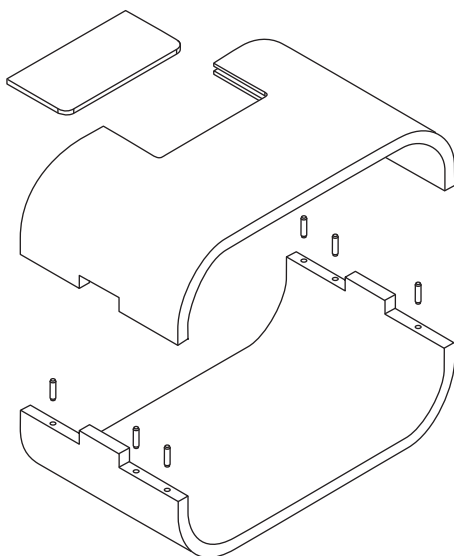

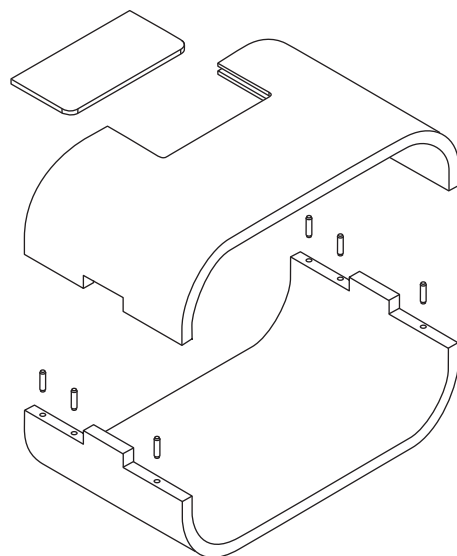



3. (continued)

MARKS DO NOT WRITE IN THIS MARGIN

- (d) Describe, using the correct dimensions and 3D CAD modelling techniques, how you would use 3D CAD software to model the television stand base.

6

You must use the additional information provided on **the supplementary sheet for use with question 3 (d)** to answer this question.

You may use sketches to support your answer.



[Turn over for next question

DO NOT WRITE ON THIS PAGE



* X 8 3 5 7 5 0 1 1 9 *

3. (continued)

A graphic designer produced an instruction booklet using desktop publishing software. A sample of the instruction booklet is shown below.

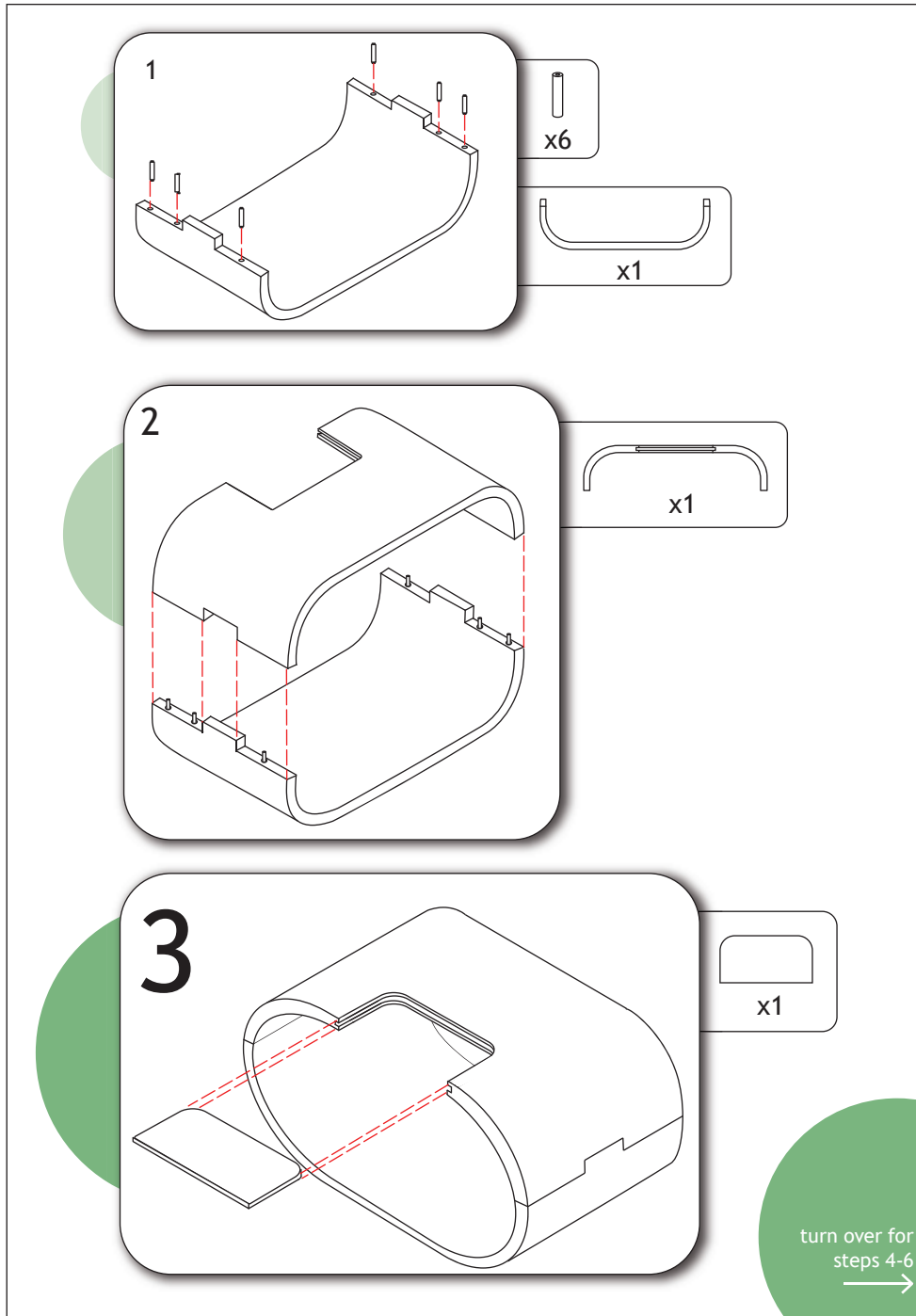

3. (continued)

- (e) Describe **four** features, other than the numbering system, that make the instructions easy to follow.

4

- (f) During the production of the instruction booklet, the graphic designer used **guidelines** and **snap to guidelines** tools in the desktop publishing software. Explain **one** advantage to the designer of using these tools when creating the instruction booklet.

1

- (g) The company decided to upload instructions to their website. Describe **two** additional features that could be added to online instructions that would not be possible in a printed instruction booklet.

2

[Turn over



4. A 3D CAD illustration of a ride-on toy is shown below.



During the design of the toy 3D printing was used.

(a) Explain **one** advantage of 3D printing when developing new products.

1

4. (continued)

3D CAD illustrations were created from the final model. Three stages of this process are shown below.

- (b) State the name of the rendering technique that has been applied to the model at stage 2 and stage 3. Stage 1 has been completed for you.

2



Stage 1

Greyscale model _____



Stage 2

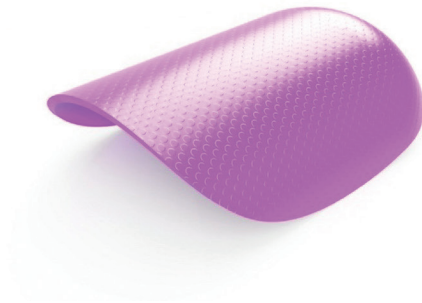

Stage 3

[Turn over



4. (continued)

The main body, wheels and seat are available in a range of colours.



- (c) (i) The main body is a tint of red.
Explain how a tint of a colour is created. 1

- (ii) The seat and wheels are available as secondary colours.
State the name of a secondary colour. 1

4. (continued)

A customer buys a red main body.



(d) State a harmonising tertiary colour for the following parts.

Your answer must be different for each part.

(i) The seat _____ 1

(ii) The wheels _____ 1

[Turn over

5. An assembled orthographic drawing of a table is shown below.

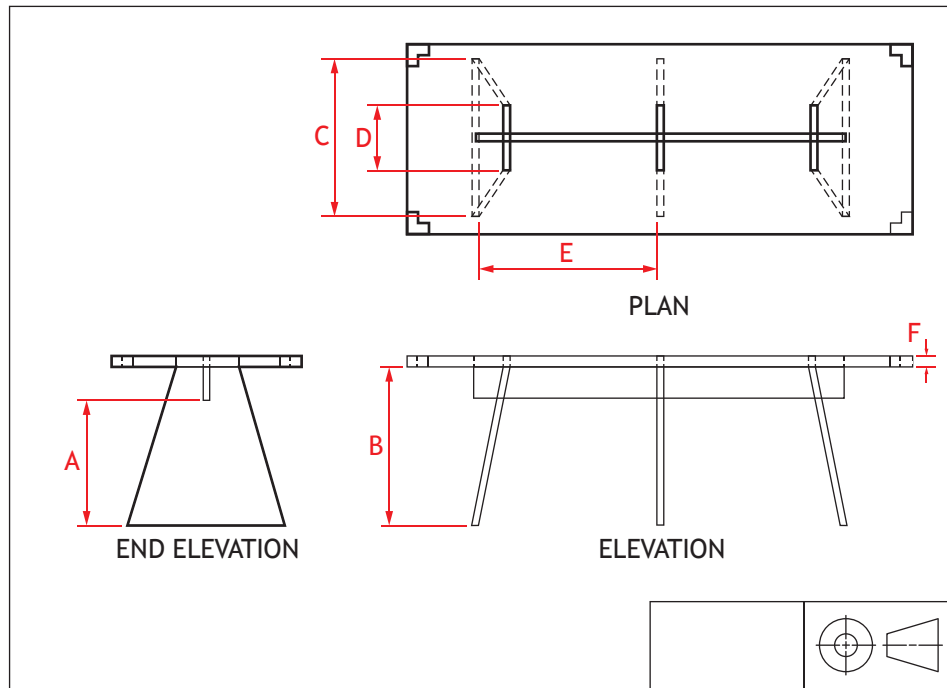

(a) Calculate the sizes for the following dimensions shown in the assembled orthographic drawing.

You must refer to the supplementary sheet for use with question 5 (a) to answer this question.

- | | |
|------------------|---|
| (i) A _____ mm | 1 |
| (ii) B _____ mm | 1 |
| (iii) C _____ mm | 1 |
| (iv) D _____ mm | 1 |
| (v) E _____ mm | 1 |
| (vi) F _____ mm | 1 |

5. (continued)

(b) An incomplete orthographic drawing of the corner block component is shown below.

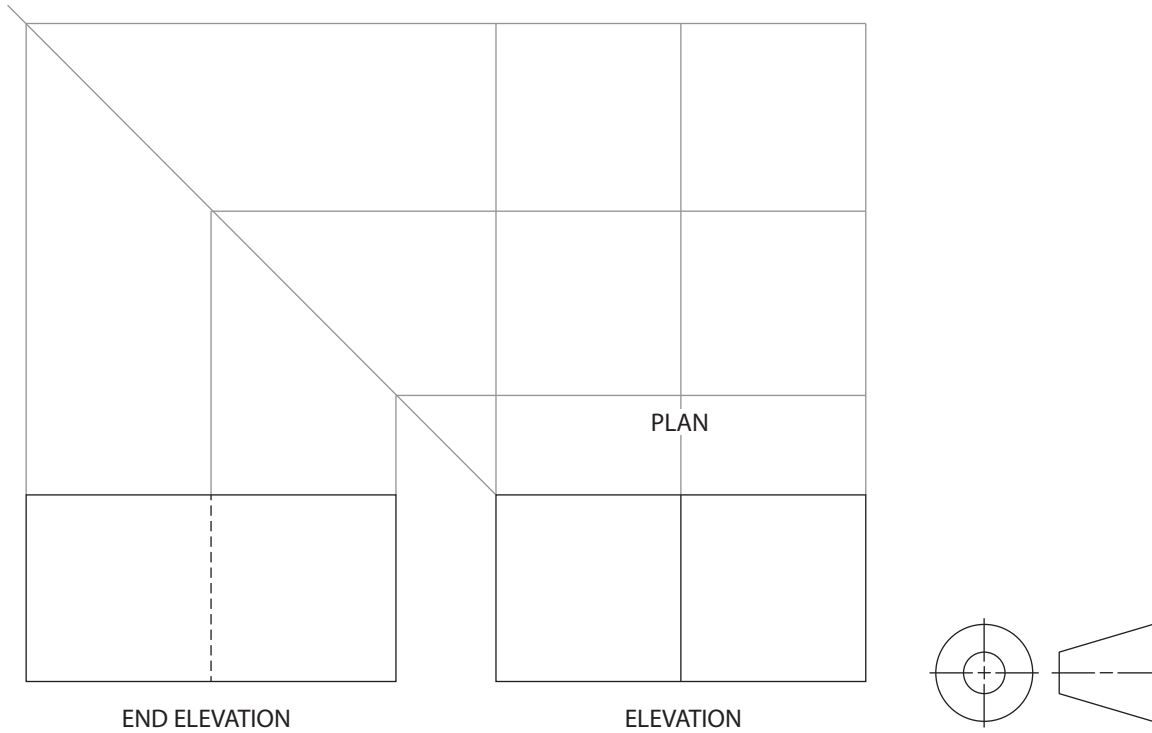

Identify the correct orientation for the plan by ticking (✓) a box below.

1

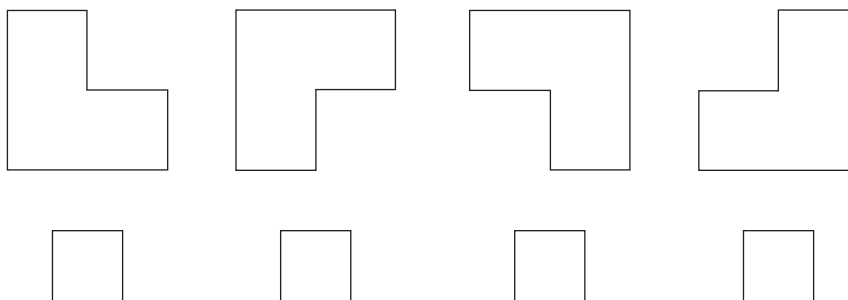

[Turn over

5. (continued)

(c) Additional rubber feet were added to the table design. An orthographic drawing of a rubber foot is shown below.

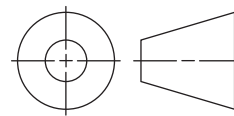
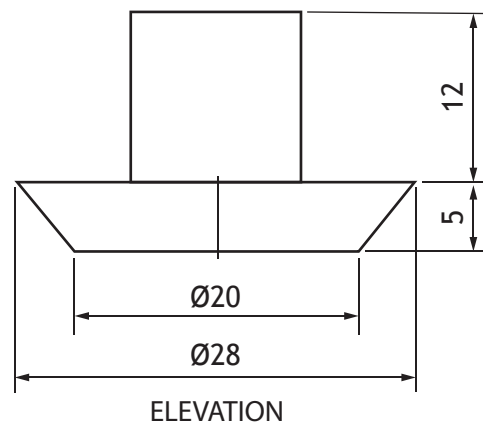
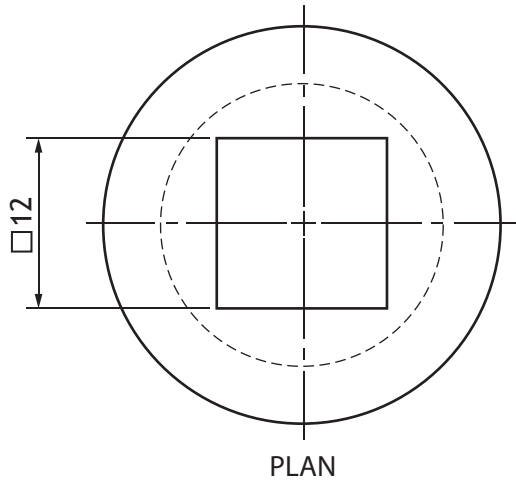

5. (c) (continued)

Describe, using the correct dimensions and 3D CAD modelling terms, how you would use 3D CAD software to model the rubber foot. You may use sketches to support your answer.

4



[END OF QUESTION PAPER]



MARKS DO NOT
WRITE IN
THIS
MARGIN

ADDITIONAL SPACE FOR ANSWERS



MARKS DO NOT
WRITE IN
THIS
MARGIN

ADDITIONAL SPACE FOR ANSWERS



[BLANK PAGE]

DO NOT WRITE ON THIS PAGE



* X 8 3 5 7 5 0 1 3 2 *