



National  
Qualifications  
2021 ASSESSMENT RESOURCE

---

**X857/75/02**

**Physics**  
**Section 1 — Questions**

Duration — 2 hours 30 minutes

---

Instructions for the completion of Section 1 are given on *page 02* of your question and answer booklet X857/75/01.

Record your answers on the answer grid on *page 03* of your question and answer booklet.

Reference may be made to the Data sheet on *page 02* of this booklet and to the Relationships sheet X857/75/11.

Before leaving the examination room you must give your question and answer booklet to the Invigilator; if you do not, you may lose all the marks for this paper.



\* X 8 5 7 7 5 0 2 \*

## DATA SHEET

### Speed of light in materials

Material	Speed in $\text{m s}^{-1}$
Air	$3.0 \times 10^8$
Carbon dioxide	$3.0 \times 10^8$
Diamond	$1.2 \times 10^8$
Glass	$2.0 \times 10^8$
Glycerol	$2.1 \times 10^8$
Water	$2.3 \times 10^8$

### Speed of sound in materials

Material	Speed in $\text{m s}^{-1}$
Aluminium	5200
Air	340
Bone	4100
Carbon dioxide	270
Glycerol	1900
Muscle	1600
Steel	5200
Tissue	1500
Water	1500

### Gravitational field strengths

	Gravitational field strength on the surface in $\text{N kg}^{-1}$
Earth	9.8
Jupiter	23
Mars	3.7
Mercury	3.7
Moon	1.6
Neptune	11
Saturn	9.0
Sun	270
Uranus	8.7
Venus	8.9

### Specific heat capacity of materials

Material	Specific heat capacity in $\text{J kg}^{-1} \text{ } ^\circ\text{C}^{-1}$
Alcohol	2350
Aluminium	902
Copper	386
Glass	500
Ice	2100
Iron	480
Lead	128
Oil	2130
Water	4180

### Specific latent heat of fusion of materials

Material	Specific latent heat of fusion in $\text{J kg}^{-1}$
Alcohol	$0.99 \times 10^5$
Aluminium	$3.95 \times 10^5$
Carbon Dioxide	$1.80 \times 10^5$
Copper	$2.05 \times 10^5$
Iron	$2.67 \times 10^5$
Lead	$0.25 \times 10^5$
Water	$3.34 \times 10^5$

### Melting and boiling points of materials

Material	Melting point in $^\circ\text{C}$	Boiling point in $^\circ\text{C}$
Alcohol	-98	65
Aluminium	660	2470
Copper	1077	2567
Lead	328	1737
Iron	1537	2737
Water	-	100

### Specific latent heat of vaporisation of materials

Material	Specific latent heat of vaporisation in $\text{J kg}^{-1}$
Alcohol	$11.2 \times 10^5$
Carbon Dioxide	$3.77 \times 10^5$
Glycerol	$8.30 \times 10^5$
Turpentine	$2.90 \times 10^5$
Water	$22.6 \times 10^5$

### Radiation weighting factors

Type of radiation	Radiation weighting factor
alpha	20
beta	1
fast neutrons	10
gamma	1
slow neutrons	3
X-rays	1

SECTION 1

Attempt ALL questions

1. Which of the following is a vector quantity?
- A force
  - B distance
  - C mass
  - D time
  - E energy
2. A skydiver falling from an aircraft reaches terminal velocity because
- A the air is very thin at high altitude
  - B there is very little friction acting on the skydiver
  - C gravitational field strength is less at high altitude
  - D the skydiver's weight is balanced by air friction
  - E the skydiver is streamlined.
3. A block of mass 5.0 kg is placed on a smooth, horizontal surface. Two forces are applied to the block as shown.

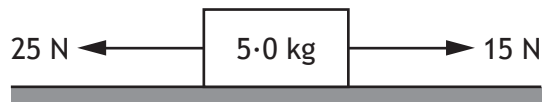

The acceleration of the block is

- A  $0.50 \text{ m s}^{-2}$
- B  $2.0 \text{ m s}^{-2}$
- C  $3.0 \text{ m s}^{-2}$
- D  $5.0 \text{ m s}^{-2}$
- E  $8.0 \text{ m s}^{-2}$ .

[Turn over

4. A student designs an experiment to investigate the relationship between the extension  $y$  of a spring and the magnitude of the force  $F$  applied to it. Different masses are attached to the spring and the length of the spring is recorded for each mass.

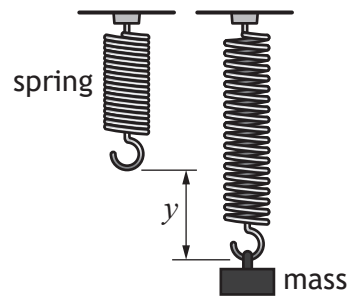

The relationship between  $F$  and  $y$  is

$$F = ky$$

where  $k$  is the spring constant of the spring.

The length of the spring with no mass attached is 0.080 m.

When a mass is attached to the spring, the length of the spring increases to 0.110 m.

The spring constant of the spring is  $12 \text{ N m}^{-1}$ .

The magnitude of the force applied to the spring is

- A 0.0025 N
- B 0.36 N
- C 1.3 N
- D 2.3 N
- E 400 N.

5. An arrow is fired horizontally with a velocity of  $60 \text{ m s}^{-1}$ .

The effects of air resistance on the arrow can be ignored.

Which pair of graphs shows how the horizontal velocity  $v_h$  and vertical velocity  $v_v$  of the arrow varies with time  $t$  during the first second of its flight?

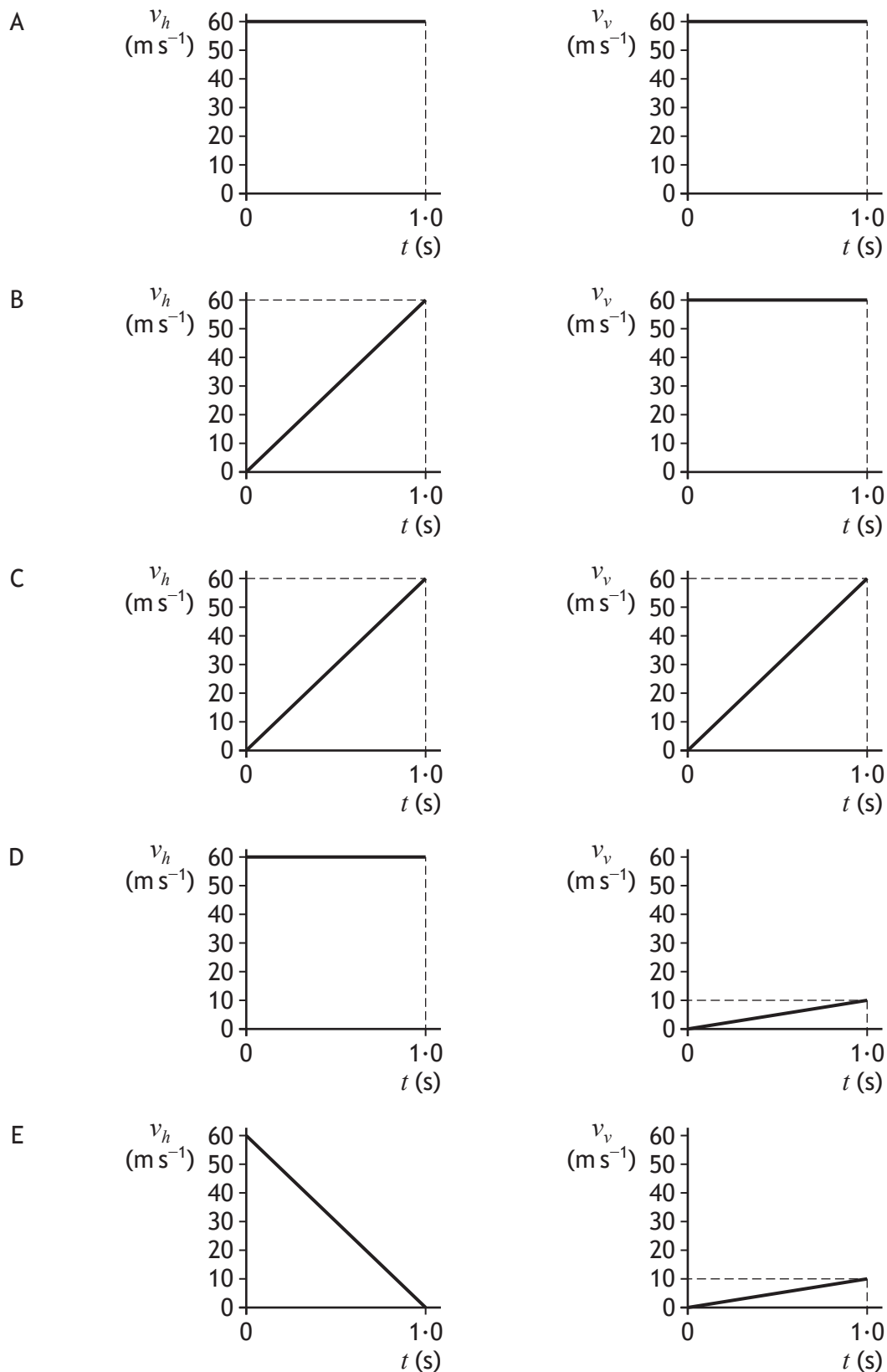

[Turn over

6. A satellite orbits the Earth at an altitude of 540 km.

The graph shows how gravitational field strength varies with altitude.

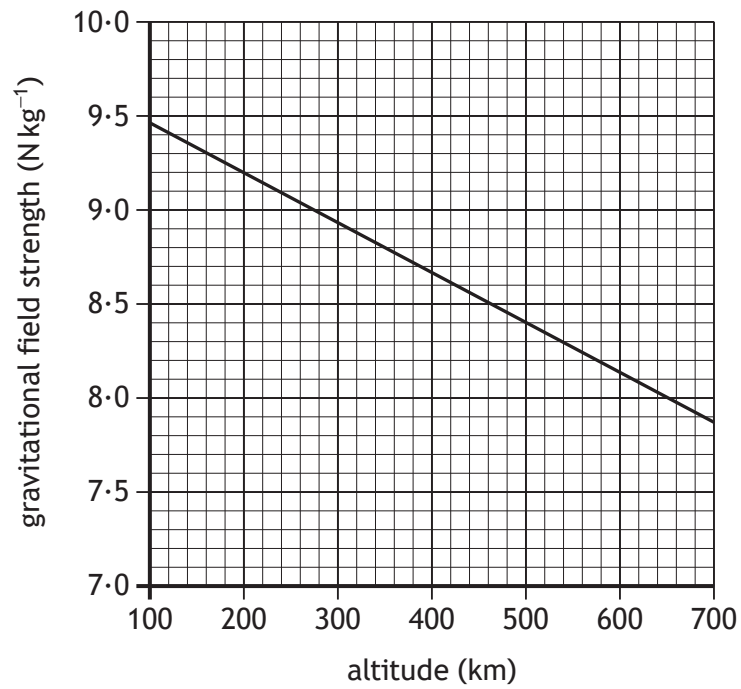

The mass of the satellite is 78 kg.

The weight of the satellite at this altitude is

- A 620 N
- B 640 N
- C 650 N
- D 740 N
- E 760 N.

7. A student makes the following statements about geostationary satellites in orbit around the Earth.
- I The orbital period of a geostationary satellite is 24 hours.
  - II Geostationary satellites remain above the same point on the Earth's surface.
  - III Geostationary satellites orbit at different altitudes.

Which of these statements is/are correct?

- A I only
  - B II only
  - C I and II only
  - D II and III only
  - E I, II and III
8. A star is  $2.4 \times 10^{18}$  m from Earth.

This distance in light-years is

- A  $3.9 \times 10^{-3}$
- B  $2.5 \times 10^2$
- C  $1.5 \times 10^4$
- D  $8.0 \times 10^9$
- E  $9.5 \times 10^{15}$ .

[Turn over

9. Light from a star is split into a line spectrum of different colours. The line spectrum from the star is shown, along with the line spectra of the elements calcium, helium, hydrogen, and sodium.

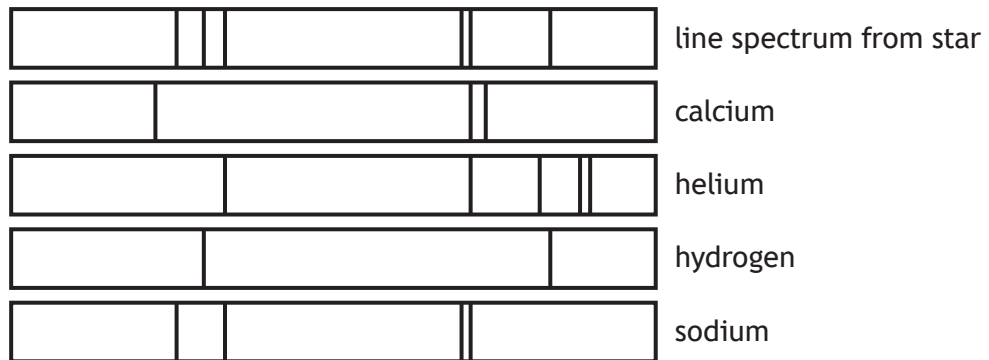

The elements present in this star are

- A sodium and calcium
- B calcium and helium
- C hydrogen and sodium
- D helium and hydrogen
- E calcium, sodium and hydrogen.



10. A heating element is connected to a 12 V supply.  
The power rating of the heating element is 48 W.  
The charge that passes through the heating element in 5 minutes is

- A 0.80 C
- B 1.25 C
- C 20 C
- D 75 C
- E 1200 C.

11. An oscilloscope is used to test three different power supplies.  
The diagrams represent the traces seen on the screen of the oscilloscope.

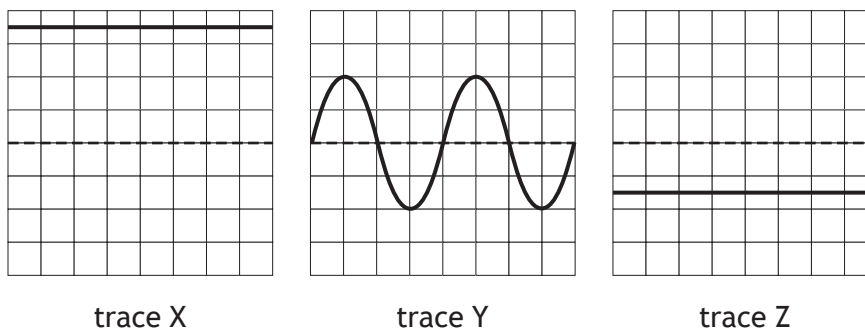

Which of these traces represent a d.c. signal?

- A X only
- B Y only
- C X and Y only
- D X and Z only
- E X, Y and Z

[Turn over

12. The graph shows how the voltage varies with current for three resistors X, Y and Z.

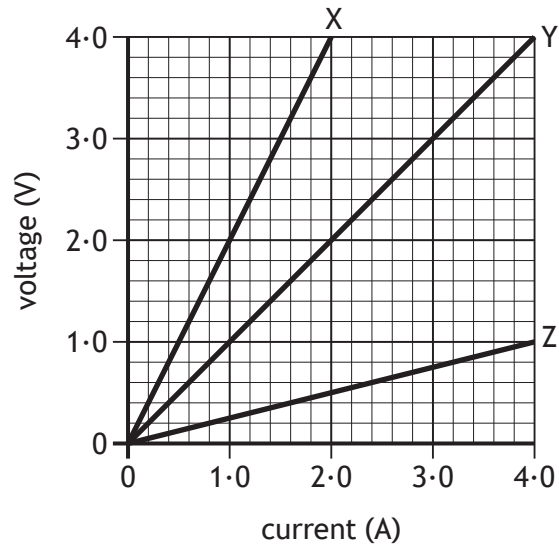

A student makes the following statements using information from the graph.

- I The resistance of resistor X is greater than that of resistors Y and Z.
- II When the voltage across resistor Y is 2.0 V, the current in the resistor is 2.0 A.
- III The resistance of resistor Z is 0.25  $\Omega$ .

Which of these statements is/are correct?

- A I only
- B II only
- C III only
- D II and III only
- E I, II and III

13. In which of the following circuits would the readings on the meters allow the resistance of  $R_2$  to be calculated?

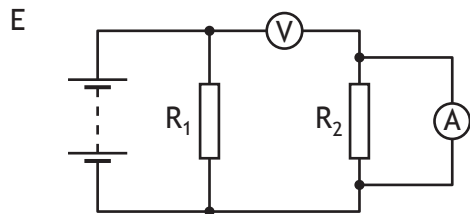
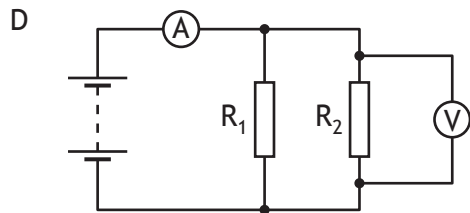
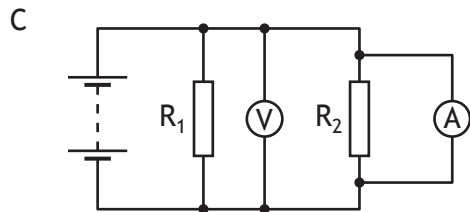
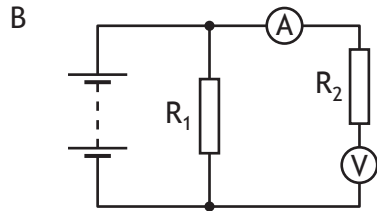
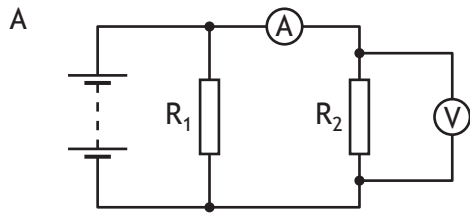

[Turn over

14. A heater is immersed in a substance.

The heater is then switched on.

The graph shows the temperature  $T$  of the substance over a period of time  $t$ .

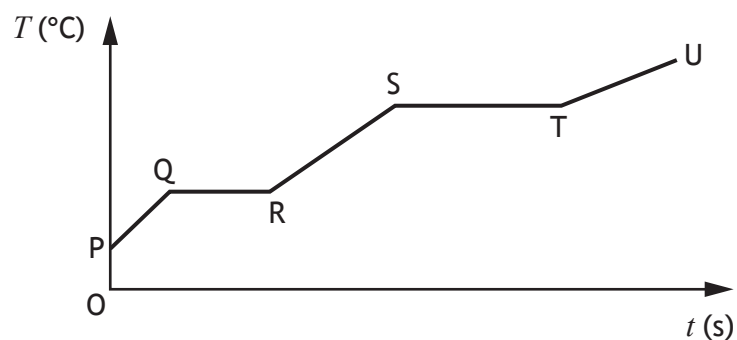

Which row in the table identifies the sections of the graph when the substance is changing state from a solid to a liquid and from a liquid to a gas?

	solid to liquid	liquid to gas
A	QR	TU
B	QR	ST
C	PQ	RS
D	PQ	TU
E	ST	QR

15. A sample of water is at a temperature of  $100\text{ }^{\circ}\text{C}$ .  
The sample absorbs  $9.0 \times 10^4\text{ J}$  of energy.  
The mass of water changed to steam at  $100\text{ }^{\circ}\text{C}$  is

- A 0.027 kg
- B 0.040 kg
- C 0.22 kg
- D 22 kg
- E 25 kg.

16. A solid rectangular block is placed on a flat, smooth table as shown.

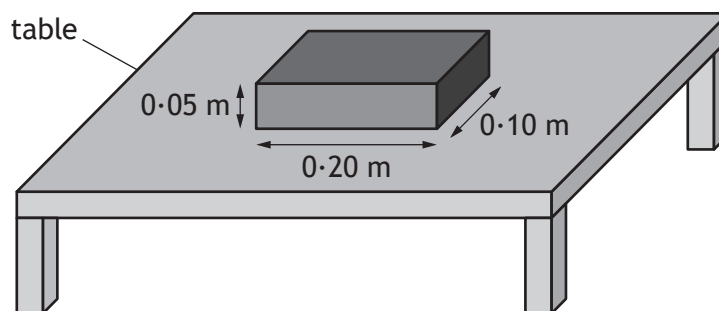

The weight of the block is 28 N.

The pressure exerted on the table by the block is

- A 140 Pa
  - B 280 Pa
  - C 560 Pa
  - D 1400 Pa
  - E 28 000 Pa.
17. A gas is contained inside a sealed syringe.  
The volume of the gas in the syringe is decreased.  
During this time the temperature of the gas is unchanged.  
This change in volume causes the gas particles to
- A move faster
  - B hit the walls of the syringe less often
  - C move slower
  - D gain kinetic energy
  - E hit the walls of the syringe more often.

[Turn over

18. A liquid is heated from 22 °C to 64 °C.

The temperature rise in kelvin is

- A 42 K
- B 86 K
- C 315 K
- D 337 K
- E 359 K.

19. Five water waves pass a point in a time of 10 seconds.

Which row in the table shows the frequency of the waves and the period of the waves?

	Frequency of the waves (Hz)	Period of the waves (s)
A	0.5	2
B	0.5	0.5
C	2	0.5
D	50	0.02
E	50	2

20. A ray of red light travels from air into a glass block.

Which row in the table shows the effect, if any, on the wavelength and speed of the red light as it passes into the glass block?

	Wavelength	Speed
A	decreases	stays the same
B	stays the same	increases
C	decreases	decreases
D	stays the same	decreases
E	increases	increases

21. Which of the following diagrams shows the path of a ray of red light as it passes from air into a glass block?

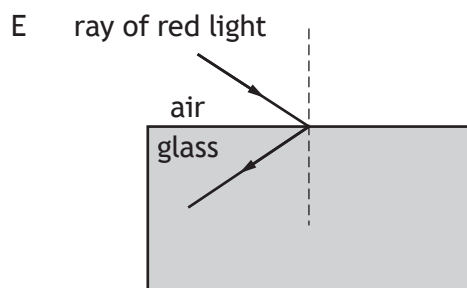
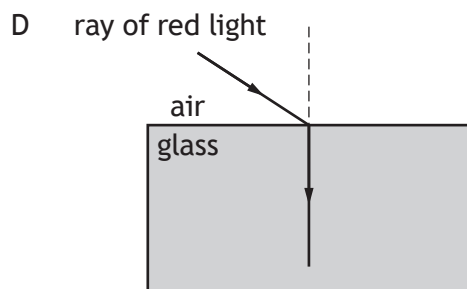
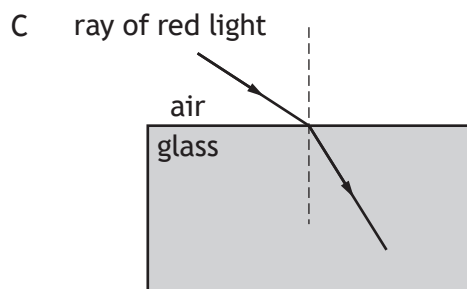
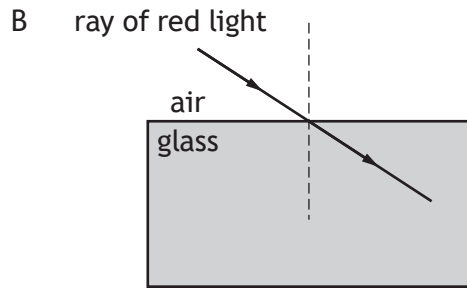
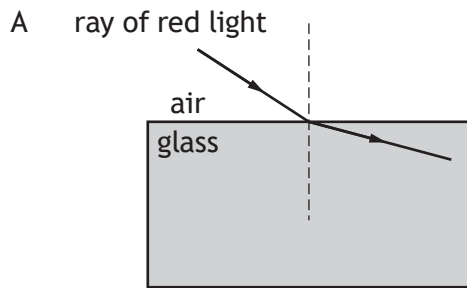

[Turn over

22. A uniform electric field exists between two oppositely charged parallel metal plates. An alpha particle, a beta particle and a gamma ray each pass between the metal plates. They follow different paths as shown.

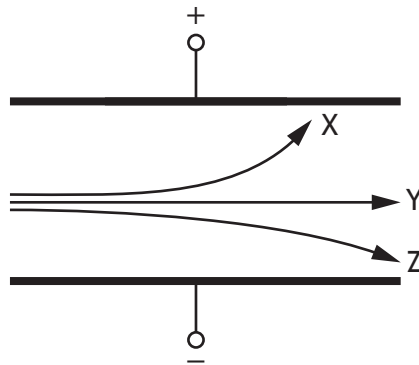

Which row in the table shows the types of radiation that follow paths X, Y and Z?

	Type of radiation that follows path X	Type of radiation that follows path Y	Type of radiation that follows path Z
A	alpha	beta	gamma
B	alpha	gamma	beta
C	beta	alpha	gamma
D	beta	gamma	alpha
E	gamma	alpha	beta

23. During ionisation an atom becomes a positive ion.  
Which of the following has been removed from the atom?
- A An electron
  - B An alpha particle
  - C A proton
  - D A neutron
  - E A gamma ray



24. A Geiger-Müller tube connected to a counter is placed in front of a radioactive source.

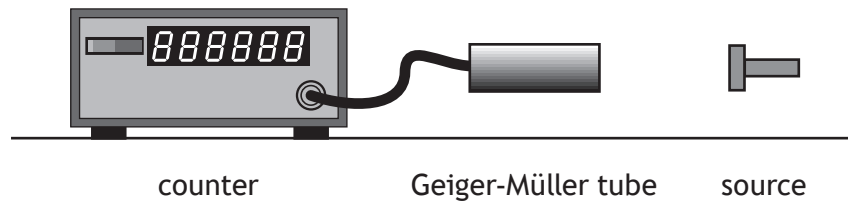

The number of counts recorded in one minute is 3890.

Different shielding materials are now placed in turn between the source and the Geiger-Müller tube, and the number of counts per minute is recorded.

Shielding material	Number of counts per minute
no shielding material	3890
sheet of paper	2110
1 cm of aluminium	2112
5 cm of lead	365

The source is emitting

- A alpha radiation only
- B beta radiation only
- C alpha and beta radiation only
- D alpha and gamma radiation only
- E beta and gamma radiation only.

25. During radiation treatment, a patient's liver absorbs 90  $\mu\text{J}$  of gamma radiation.

The mass of the liver is 2.0 kg.

The absorbed dose received by the liver is

- A 45  $\mu\text{Gy}$
- B 88  $\mu\text{Gy}$
- C 90  $\mu\text{Gy}$
- D 92  $\mu\text{Gy}$
- E 180  $\mu\text{Gy}$ .

[END OF SECTION 1. NOW ATTEMPT THE QUESTIONS IN SECTION 2 OF YOUR QUESTION AND ANSWER BOOKLET]

[BLANK PAGE]

DO NOT WRITE ON THIS PAGE

[BLANK PAGE]

DO NOT WRITE ON THIS PAGE

**[BLANK PAGE]**

**DO NOT WRITE ON THIS PAGE**