



National
Qualifications
2023

X857/75/02

Physics
Section 1 — Questions

WEDNESDAY, 17 MAY

1:00 PM – 3:30 PM

Instructions for the completion of Section 1 are given on *page 02* of your question and answer booklet X857/75/01.

Record your answers on the answer grid on *page 03* of your question and answer booklet.

Reference may be made to the Data Sheet on *page 02* of this booklet and to the Relationship Sheet X857/75/11.

Before leaving the examination room you must give your question and answer booklet to the Invigilator; if you do not, you may lose all the marks for this paper.



* X 8 5 7 7 5 0 2 *

DATA SHEET

Speed of light in materials

Material	Speed in m s^{-1}
Air	3.0×10^8
Carbon dioxide	3.0×10^8
Diamond	1.2×10^8
Glass	2.0×10^8
Glycerol	2.1×10^8
Water	2.3×10^8

Speed of sound in materials

Material	Speed in m s^{-1}
Aluminium	5200
Air	340
Bone	4100
Carbon dioxide	270
Glycerol	1900
Muscle	1600
Steel	5200
Tissue	1500
Water	1500

Gravitational field strengths

	Gravitational field strength on the surface in N kg^{-1}
Earth	9.8
Jupiter	23
Mars	3.7
Mercury	3.7
Moon	1.6
Neptune	11
Saturn	9.0
Sun	270
Uranus	8.7
Venus	8.9

Specific heat capacity of materials

Material	Specific heat capacity in $\text{J kg}^{-1} \text{ }^\circ\text{C}^{-1}$
Alcohol	2350
Aluminium	902
Copper	386
Glass	500
Ice	2100
Iron	480
Lead	128
Oil	2130
Water	4180

Specific latent heat of fusion of materials

Material	Specific latent heat of fusion in J kg^{-1}
Alcohol	0.99×10^5
Aluminium	3.95×10^5
Carbon Dioxide	1.80×10^5
Copper	2.05×10^5
Iron	2.67×10^5
Lead	0.25×10^5
Water	3.34×10^5

Melting and boiling points of materials

Material	Melting point in $^\circ\text{C}$	Boiling point in $^\circ\text{C}$
Alcohol	-98	65
Aluminium	660	2470
Copper	1077	2567
Lead	328	1737
Iron	1537	2737
Water	-	100

Specific latent heat of vaporisation of materials

Material	Specific latent heat of vaporisation in J kg^{-1}
Alcohol	11.2×10^5
Carbon Dioxide	3.77×10^5
Glycerol	8.30×10^5
Turpentine	2.90×10^5
Water	22.6×10^5

Radiation weighting factors

Type of radiation	Radiation weighting factor
alpha	20
beta	1
fast neutrons	10
gamma	1
slow neutrons	3
X-rays	1

SECTION 1 — 25 marks

Attempt ALL questions

1. The letters X, Y, and Z represent missing words from the following passage.

Quantities that have both a magnitude and a direction are called . . . X

Two examples of this type of quantity are . . . Y . . . and . . . Z

Which row in the table shows the missing words?

	X	Y	Z
A	scalars	energy	mass
B	scalars	force	acceleration
C	vectors	energy	mass
D	vectors	force	acceleration
E	vectors	energy	force

[Turn over

2. A trolley is released from the top of a slope and passes between two light gates P and Q. The distance between the light gates is d .

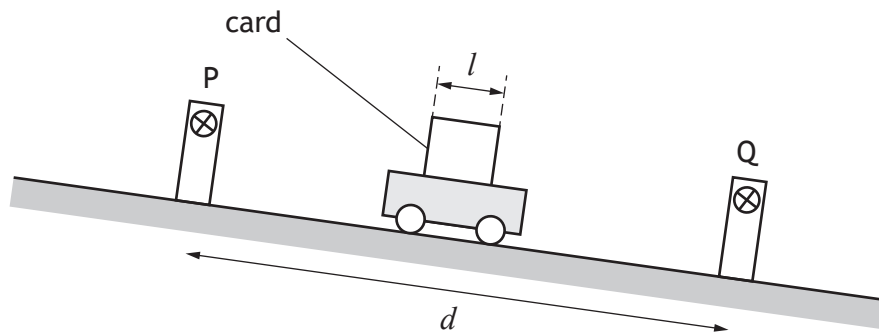

The time taken for the card to pass through light gate P is t_1 .

The time taken for the card to pass through light gate Q is t_2 .

The length of the card on the trolley is l .

The instantaneous speed of the trolley at light gate Q is given by

A $\frac{d}{t_1 + t_2}$

B $\frac{l}{t_1 + t_2}$

C $\frac{l}{t_1}$

D $\frac{l}{t_2}$

E $\frac{d}{t_2}$

3. The graph shows how the speed of a runner changes during the last 8.0 seconds of a race.

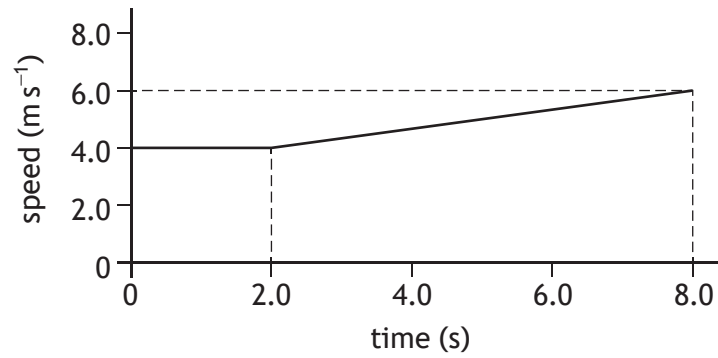

The distance travelled during the 8.0 seconds is

- A 24 m
 - B 32 m
 - C 38 m
 - D 44 m
 - E 48 m.
4. A block is pushed 3.0 m up a slope by a constant force of 6.0 N.

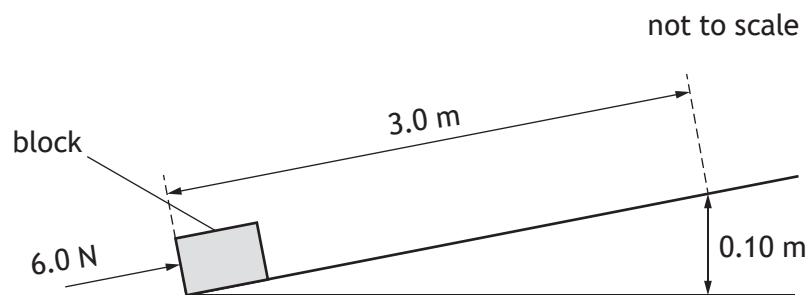

The force of friction between the block and the slope is 2.0 N.

The mass of the block is 1.5 kg.

The work done by the pushing force in moving the block 3.0 m up the slope is

- A 1.5 J
- B 6.0 J
- C 12 J
- D 18 J
- E 24 J.

[Turn over

5. A trolley of mass 4.0 kg is travelling along a track.
The trolley accelerates from 2.0 m s^{-1} to 6.0 m s^{-1} .
The increase in kinetic energy of the trolley is

- A 32 J
- B 64 J
- C 72 J
- D 80 J
- E 128 J.

6. The natural greenhouse effect is vital for sustaining life on Earth.
The 'no greenhouse' temperature is the average surface temperature of Earth if there were no natural greenhouse effect.

The 'no greenhouse' temperature T can be determined using the relationship

$$T^2 = 280^2 \times \sqrt{\frac{(1-\alpha)}{d^2}}$$

where: T is the 'no greenhouse' temperature in kelvin

α is the proportion of incoming solar radiation that Earth reflects

d is the mean distance from the Sun in astronomical units (AU).

The value of α for Earth is taken to be 0.290 and the mean distance from the Sun to Earth is 1.00 AU.

The 'no greenhouse' temperature of Earth is

- A 14.1 K
- B 15.4 K
- C 236 K
- D 257 K
- E 66 100 K.

7. Doris is a small, rocky, irregular shaped object that orbits the Sun between Mars and Jupiter.
Doris is an example of

- A an asteroid
- B a dwarf planet
- C an exoplanet
- D a planet
- E a star.

8. A space vehicle of mass 350 kg is free falling vertically towards the surface of Mars.
Rocket engines are now fired, which apply a combined upwards force of 2200 N on the vehicle.

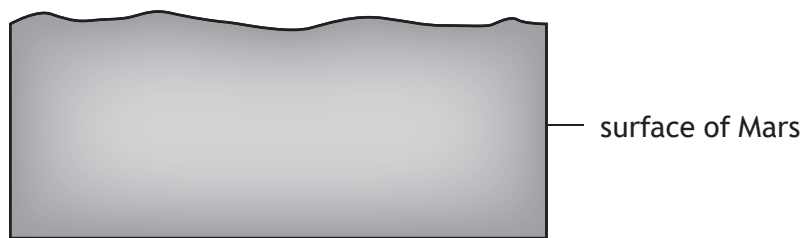
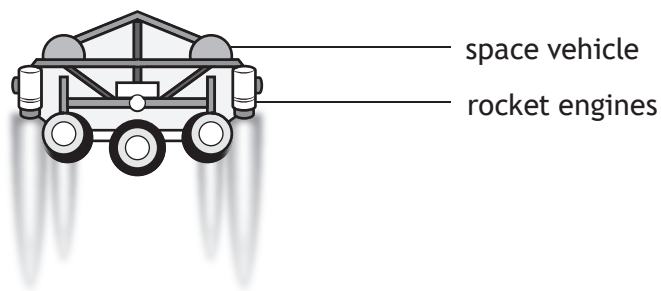

Just after the rocket engines are fired, the vehicle will

- A move away from the surface of Mars at a constant speed
- B move away from the surface of Mars with an increasing speed
- C move towards the surface of Mars at a constant speed
- D move towards the surface of Mars with a decreasing speed
- E move towards the surface of Mars with an increasing speed.

[Turn over

9. A uniform electric field exists between plates Q and R.
The diagram shows the path taken by particle P as it passes through the field.

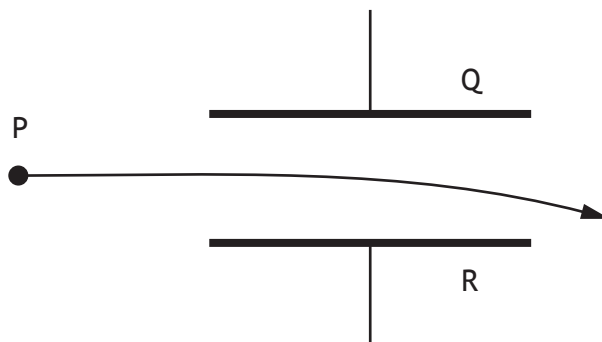

Which row in the table identifies the charge on particle P, the charge on plate Q, and the charge on plate R?

	Charge on particle P	Charge on plate Q	Charge on plate R
A	negative	positive	negative
B	no charge	negative	positive
C	no charge	positive	negative
D	positive	negative	positive
E	positive	positive	negative

10. Alternating current (a.c.) can be defined as a current where

- A only negative charges move
- B charges move in one direction only
- C charges reverse direction at regular intervals
- D only positive charges move
- E the rate of flow of charge is constant.

11. A circuit is set up as shown.

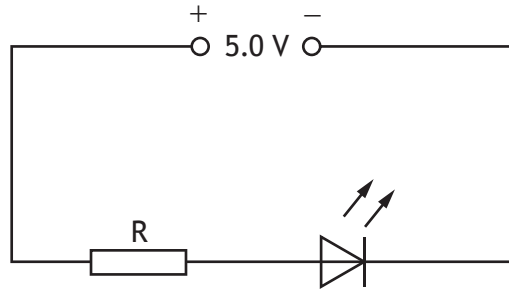

The voltage across the LED is 2.2 V.

The current in the LED is 10.0 mA.

The resistance of resistor R is

- A 0.22 Ω
- B 0.28 Ω
- C 220 Ω
- D 280 Ω
- E 500 Ω .

12. A circuit is set up as shown.

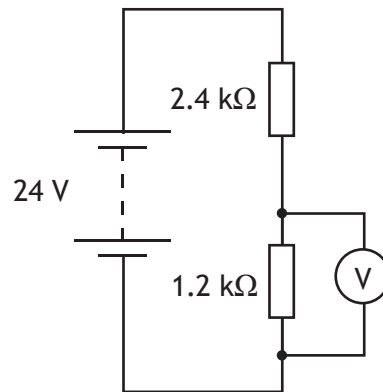

The reading on the voltmeter is

- A 8 V
- B 10 V
- C 16 V
- D 20 V
- E 24 V.

[Turn over

13. A circuit containing an LDR switches on a motor when the light level drops below a certain value.

The resistance of the LDR increases as the light level decreases.

Which of the following shows this circuit?

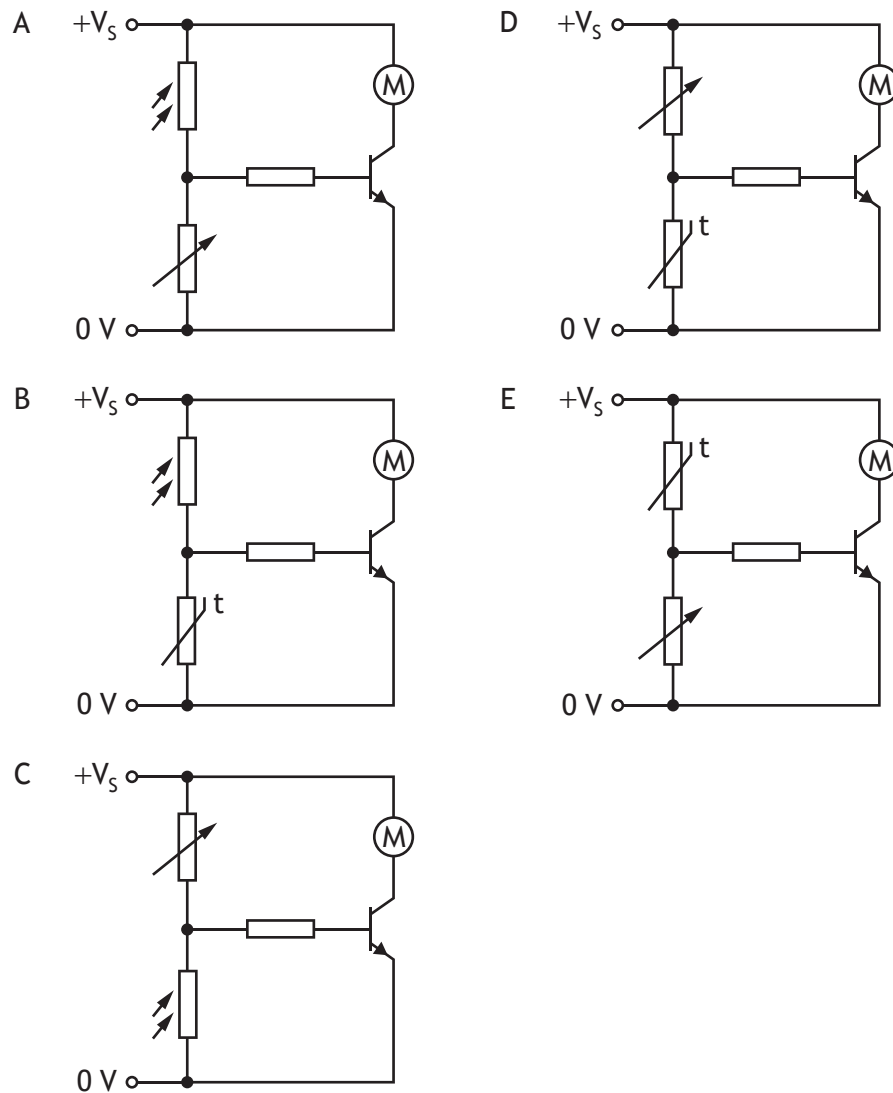

14. A slow cooker has a power rating of 250 W.
The slow cooker is switched on for 2 hours.
The energy used by the slow cooker in this time is

- A 25 J
- B 500 J
- C 30 000 J
- D 900 000 J
- E 1 800 000 J.

15. A student investigates the relationship between the power developed in a resistor and the resistance of the resistor. The voltage across the resistor and the temperature of the resistor are kept constant during the investigation.

The graph shows the results.

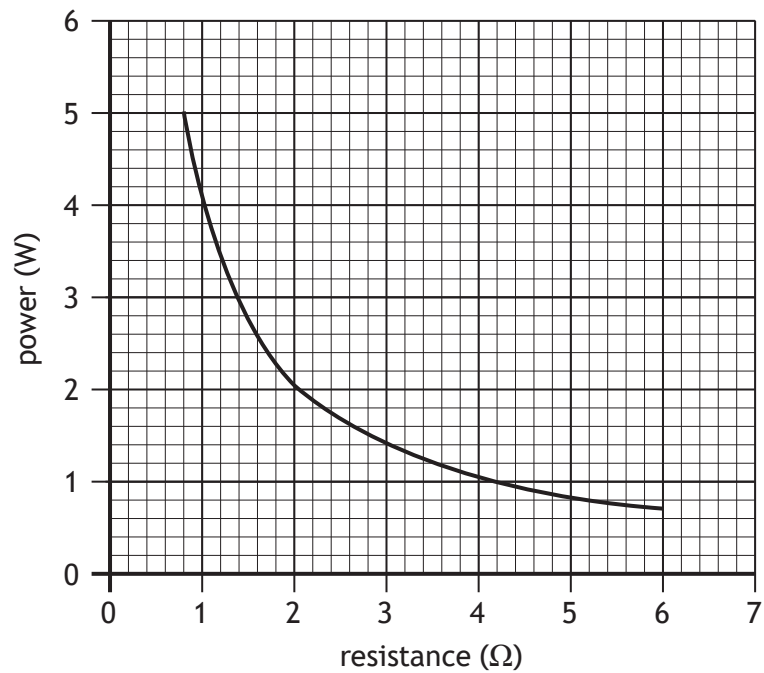

The voltage across the resistor is

- A 0.50 V
- B 1.0 V
- C 2.0 V
- D 4.0 V
- E 16 V.

[Turn over

16. A student carries out an experiment to determine the specific heat capacity of copper using the apparatus shown.

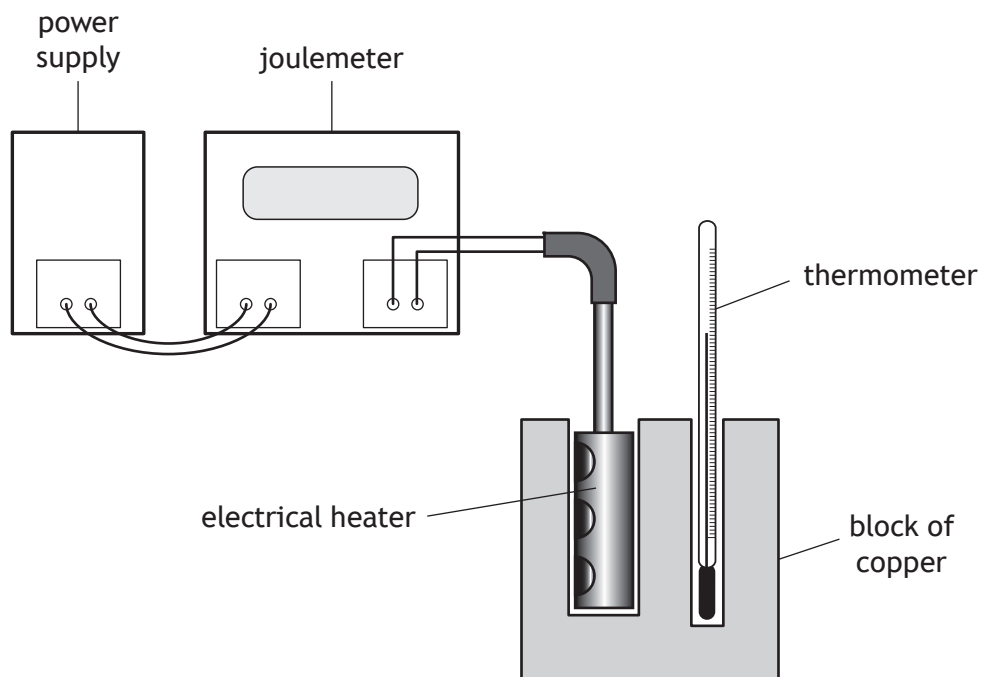

The student switches on the power supply and the electrical heater heats the block of copper.

The joulemeter measures the energy supplied to the electrical heater.

The student suggests the following measurements should also be made:

- I The mass of the block of copper.
- II The initial and final readings on the thermometer.
- III The power rating of the electrical heater.

Which of these measurements **must** be made to determine the specific heat capacity of copper?

- A I only
- B II only
- C I and II only
- D II and III only
- E I, II and III

17. The minimum energy required to melt 3.5 kg of ice at its melting point into water at the same temperature is
- A 1.5×10^4 J
 - B 1.2×10^6 J
 - C 7.9×10^6 J
 - D 1.2×10^9 J
 - E 7.9×10^9 J.
18. A hammer hits a nail with a force of 5.0 kN.
The pressure exerted by the hammer on the nail is 2.0×10^8 Pa.
The area of the nail hit by the hammer is
- A 2.5×10^{-8} m²
 - B 2.5×10^{-5} m²
 - C 4.0×10^4 m²
 - D 4.0×10^7 m²
 - E 1.0×10^{12} m².
19. A sealed hollow buoy drifts from warm Atlantic waters into colder Arctic waters.
The volume of the buoy remains constant.
The pressure of the trapped air inside the buoy changes because pressure is
- A directly proportional to the temperature in kelvin
 - B inversely proportional to the temperature in kelvin
 - C inversely proportional to the volume of the air inside the buoy
 - D inversely proportional to the temperature in degrees Celsius
 - E directly proportional to the temperature in degrees Celsius.

[Turn over

20. The pressure of a fixed mass of gas is 5.0×10^5 Pa. The temperature of the gas is 320 K and the volume of the gas is 2.2 m^3 .

The gas is then heated to a temperature of 370 K and the pressure of the gas increases to 5.5×10^5 Pa.

The new volume of the gas is

- A 1.7 m^3
 - B 2.1 m^3
 - C 2.3 m^3
 - D 2.8 m^3
 - E 4.1 m^3 .
21. The diagram represents a wave.

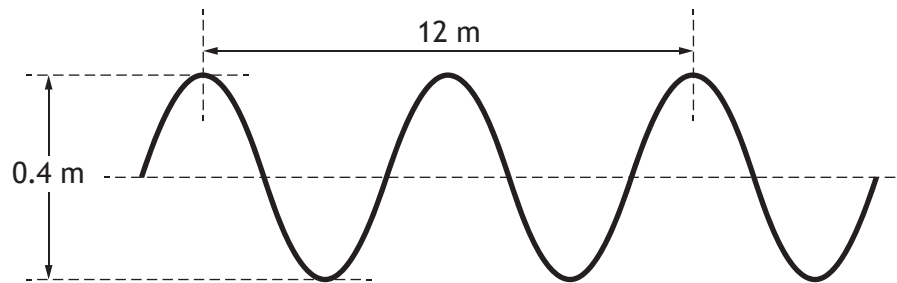

The speed of the wave is 3.0 m s^{-1} .

Which row in the table shows the amplitude and frequency of this wave?

	Amplitude (m)	Frequency (Hz)
A	0.2	0.25
B	0.2	0.50
C	0.2	2.0
D	0.4	0.50
E	0.4	2.0

22. Which diagram shows the diffraction of water waves as they pass through a gap in a barrier?

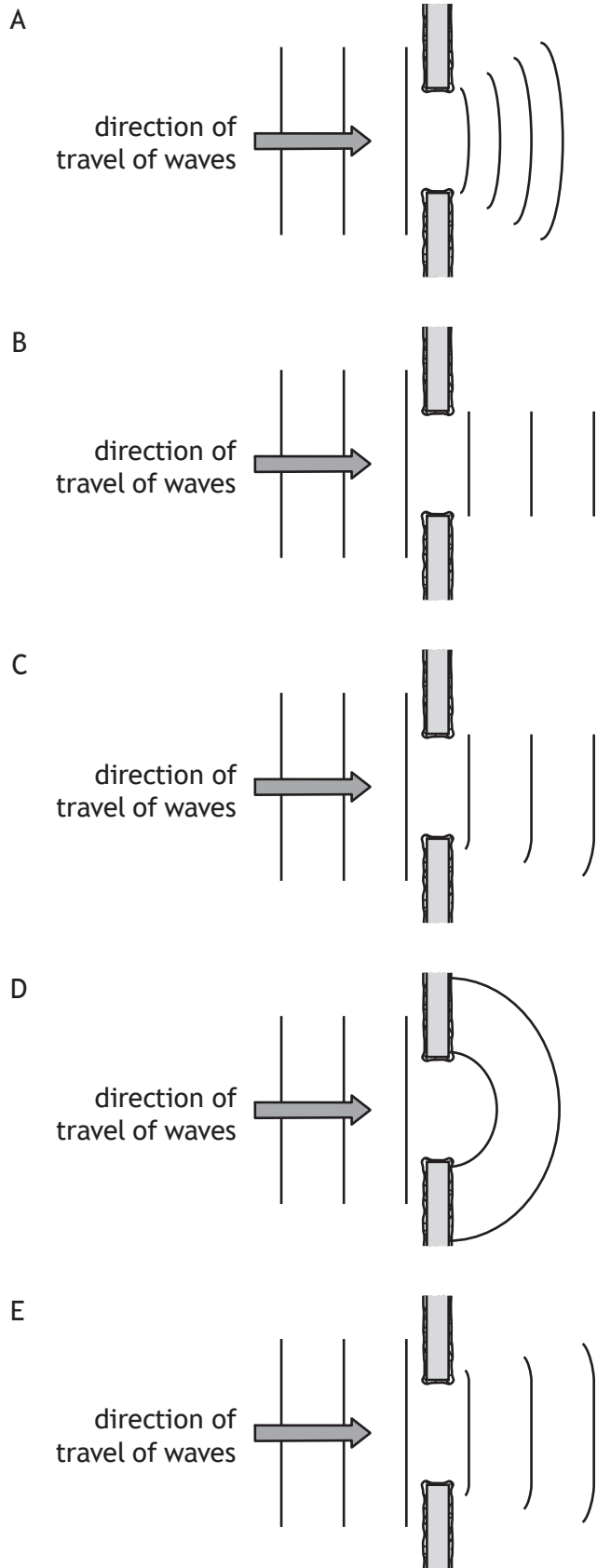

23. A ray of red light passes through a glass block as shown.

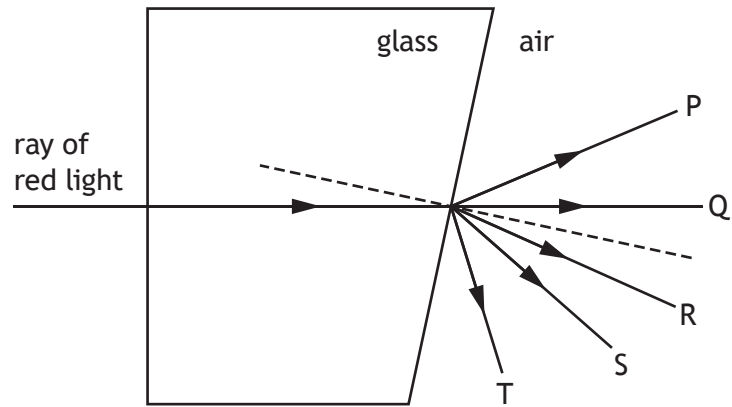

Which ray shows the path of the red light in air?

- A P
- B Q
- C R
- D S
- E T

24. A sample of uranium has an activity of 2.4×10^4 Bq.
The number of nuclei decaying in 15 minutes is

- A 2.7×10^1
- B 1.6×10^3
- C 2.4×10^4
- D 3.6×10^5
- E 2.2×10^7

25. A student makes the following statements about nuclear fusion:

- I Nuclear fusion is when a large nucleus splits into smaller nuclei.
- II Plasma containment is required to sustain nuclear fusion reactions in a reactor.
- III Nuclear fusion takes place at low temperatures.

Which of these statements is/are correct?

- A I only
- B II only
- C I and II only
- D I and III only
- E II and III only

**[END OF SECTION 1. NOW ATTEMPT THE QUESTIONS IN SECTION 2 OF
YOUR QUESTION AND ANSWER BOOKLET]**

SPACE FOR ROUGH WORK

SPACE FOR ROUGH WORK

[BLANK PAGE]

DO NOT WRITE ON THIS PAGE