

FOR OFFICIAL USE



National
Qualifications
2023

Mark

X857/75/01

**Physics
Section 1 — Answer grid
and Section 2**

WEDNESDAY, 17 MAY

1:00 PM – 3:30 PM



* X 8 5 7 7 5 0 1 *

Fill in these boxes and read what is printed below.

Full name of centre

Town

Forename(s)

Surname

Number of seat

Date of birth

Day

Month

Year

Scottish candidate number

Total marks — 135

SECTION 1 — 25 marks

Attempt ALL questions.

Instructions for completion of Section 1 are given on *page 02*.

SECTION 2 — 110 marks

Attempt ALL questions.

Reference may be made to the Data sheet on *page 02* of the question paper X857/75/02 and to the Relationships sheet X857/75/11.

Write your answers clearly in the spaces provided in this booklet. Additional space for answers and rough work is provided at the end of this booklet. If you use this space you must clearly identify the question number you are attempting. Any rough work must be written in this booklet. Score through your rough work when you have written your final copy.

Use **blue** or **black** ink.

Before leaving the examination room you must give this booklet to the Invigilator; if you do not, you may lose all the marks for this paper.



* X 8 5 7 7 5 0 1 0 1 *

SECTION 1 — 25 marks

The questions for Section 1 are contained in the question paper X857/75/02.

Read these and record your answers on the answer grid on *page 03* opposite.

Use **blue** or **black** ink. Do NOT use gel pens or pencil.

1. The answer to each question is **either** A, B, C, D or E. Decide what your answer is, then fill in the appropriate bubble (see sample question below).
2. There is **only one correct** answer to each question.
3. Any rough work must be written in the additional space for answers and rough work at the end of this booklet.

Sample question

The energy unit measured by the electricity meter in your home is the

- A ampere
- B kilowatt-hour
- C watt
- D coulomb
- E volt.

The correct answer is **B** — kilowatt-hour. The answer **B** bubble has been clearly filled in (see below).

A	B	C	D	E
<input type="radio"/>	<input checked="" type="radio"/>	<input type="radio"/>	<input type="radio"/>	<input type="radio"/>

Changing an answer

If you decide to change your answer, cancel your first answer by putting a cross through it (see below) and fill in the answer you want. The answer below has been changed to **D**.

A	B	C	D	E
<input type="radio"/>	<input checked="" type="radio"/>	<input type="radio"/>	<input checked="" type="radio"/>	<input type="radio"/>

If you then decide to change back to an answer you have already scored out, put a tick (✓) to the **right** of the answer you want, as shown below:

A	B	C	D	E	or	A	B	C	D	E
<input type="radio"/>	<input checked="" type="radio"/>	<input type="radio"/>	<input checked="" type="radio"/>	<input type="radio"/>		<input type="radio"/>	<input checked="" type="radio"/>	<input type="radio"/>	<input type="radio"/>	<input type="radio"/>



SECTION 1 — Answer grid



* O B J 2 5 A E 1 *

You must record your answers
to Section 1 questions on the
answer grid on **page 03**
of your **answer booklet**.



* X 8 5 7 7 5 0 1 0 3 *

[BLANK PAGE]

DO NOT WRITE ON THIS PAGE



[Turn over for SECTION 2

DO NOT WRITE ON THIS PAGE



SECTION 2 — 110 marks

Attempt ALL questions

1. A seagull flies above a school playground. The seagull remains at a constant height above the ground during its flight.

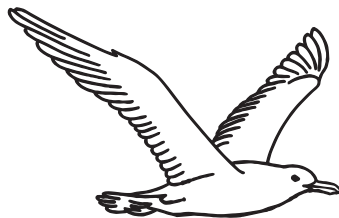

- (a) The seagull flies from point A to point E following the route shown.

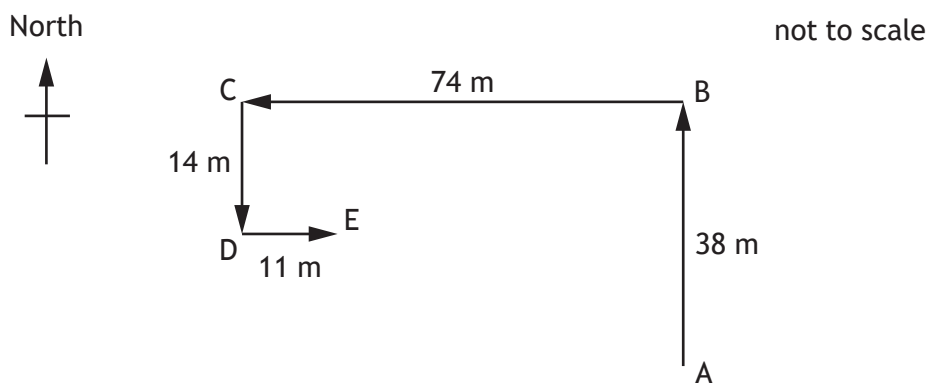

- (i) By scale diagram or otherwise, determine the magnitude of the resultant displacement of the seagull from point A to point E.

2

Space for working and answer



1. (a) (continued)

- (ii) By scale diagram or otherwise, determine the direction of the resultant displacement of the seagull from point A to point E.

2

Space for working and answer

- (b) The seagull takes 31 s to travel from point A to point E.

- (i) Determine the average velocity of the seagull for this journey.

3

Space for working and answer

- (ii) A student states that the average speed of the seagull between point A and point E is greater than the magnitude of the average velocity of the seagull between point A and point E.

Explain why the student is correct.

2



* X 8 5 7 7 5 0 1 0 7 *

1. (continued)

- (c) The seagull now flies at a height of 7.5 m above the ground, holding a chip in its beak.

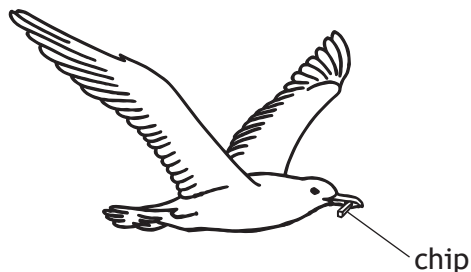

The mass of the chip is 0.0025 kg.

- (i) Show that the gravitational potential energy of the chip at this height is 0.18 J.

2

Space for working and answer

- (ii) The seagull now drops the chip.

Determine the maximum vertical speed of the chip as it reaches the ground.

3

Space for working and answer



1. (c) (continued)

(iii) Explain why, in practice, the vertical speed of the chip as it reaches the ground is less than determined in (c) (ii).

1

[Turn over



2. During a cycle race, a cyclist attempts to pass a water bottle to a team-mate.



The cyclist is travelling in a straight line at 12.5 m s^{-1} when they drop the bottle. The bottle hits the ground 0.53 s later.

The effects of air resistance on the bottle are negligible.

- (a) A spectator at the side of the road observes the cyclist dropping the bottle.

On the diagram below, sketch the path taken by the bottle from the point it is dropped, as observed by the spectator at the side of the road.

1



(An additional diagram, if required, can be found on *page 46*.)

- (b) (i) Calculate the vertical velocity of the bottle as it reaches the ground.

3

Space for working and answer



2. (b) (continued)

- (ii) Sketch a velocity-time graph showing the magnitude of the vertical velocity of the bottle from the time it is released until it reaches the ground.

Numerical values are required on both axes.

2



(An additional graph, if required, can be found on page 46.)

- (iii) Determine the height from which the bottle was dropped.

Space for working and answer

3

[Turn over



2. (continued)

- (c) At another point in the race, the cyclist rides behind their team-mate along a straight, flat section of road.



- (i) The cyclist and bike have a combined mass of 74 kg.
The cyclist produces a forward force of 54 N.
The total frictional force acting on the cyclist and bike is 22 N.
Determine the acceleration of the cyclist and bike.

Space for working and answer

4

- (ii) Explain, in terms of the forces acting on the cyclist, the advantage of cycling behind a team-mate.

1



[Turn over for next question

DO NOT WRITE ON THIS PAGE



* X 8 5 7 7 5 0 1 1 3 *

3. Information about some satellites is shown in the table.

Name of satellite	Date launched	Orbital altitude h (km)	Orbital period T
UKube-1	8 July 2014	825	101 minutes
Kosmos 2460	1 March 2010	19 100	676 minutes
Magellan	22 August 2019	20 200	718 minutes
Astra 1KR	20 April 2006	36 000	24 hours
Vela 4B	28 April 1967	111 000	111 hours

- (a) Television signals are transmitted from satellites that remain above the same point on Earth's surface at all times.

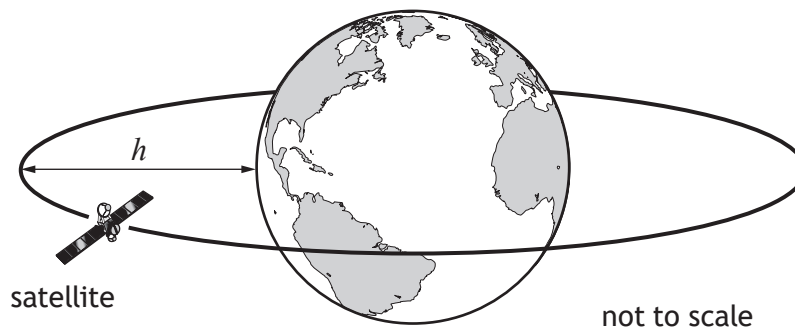

State which of the satellites in the table is used to transmit these television signals.

You must justify your answer.

2

3. (continued)

(b) UKube-1 has a mass of 3.5 kg.

At an orbital altitude of 825 km the gravitational field strength of Earth is 7.7 N kg^{-1} .

Calculate the weight of UKube-1 at this orbital altitude.

3

Space for working and answer

(c) Another satellite is in orbit at an altitude of 1200 km.

Predict the orbital period of this satellite.

1

[Turn over



4. A space scientist makes the following statement.

‘Before we can have human space exploration of the solar system and beyond, we need to build a base on the Moon.’

Using your knowledge of physics, comment on the benefits and/or challenges of using a base on the Moon from which humans could explore the solar system and beyond.

3



* X 8 5 7 7 5 0 1 1 6 *

DO NOT
WRITE IN
THIS
MARGIN

4. (continued)



* X 8 5 7 7 5 0 1 1 7 *

5. (continued)

(c) The star is 343 light-years from Earth.

Show that the distance from the star to Earth is 3.2×10^{18} m.

Space for working and answer

2

[Turn over



6. A student sets up the following circuit.

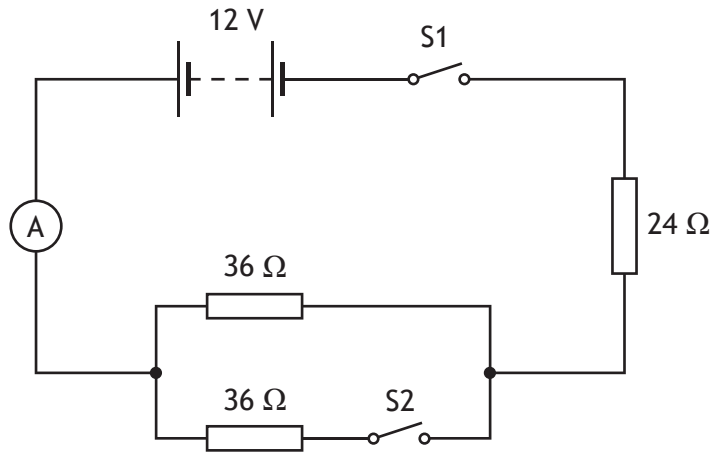

Initially, both switch S1 and switch S2 are open

(a) The student closes switch S1.

Determine the reading on the ammeter.

Space for working and answer

4

(b) The student now also closes switch S2.

(i) Determine the total resistance of this circuit.

Space for working and answer

4



6. (b) (continued)

- (ii) State whether the reading on the ammeter will now be less than, equal to or greater than the value determined in (a).

You must justify your answer.

2

[Turn over



7. A capacitor consisting of two parallel metal plates, X and Y, is connected in a circuit as shown.

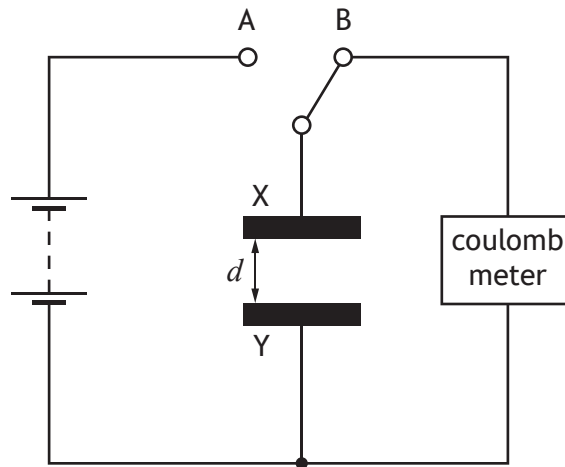

The distance d between plate X and plate Y can be adjusted.

The capacitor is initially uncharged.

The switch is moved to position A and charge is transferred to the capacitor.

The switch is now moved to position B and the charge Q stored on the capacitor is measured by the coulombmeter.

This process is repeated for a range of different distances d between plate X and plate Y.

- (a) The charge Q stored on the capacitor for a range of different distances d between plate X and plate Y is shown in the table.

d (mm)	Q ($\times 10^{-12}$ C)
10	178
20	90
30	62
40	47
50	37



7. (a) (continued)

(i) Using the graph paper, draw a graph of these results.

(Additional graph paper, if required, can be found on *page 47.*)

3

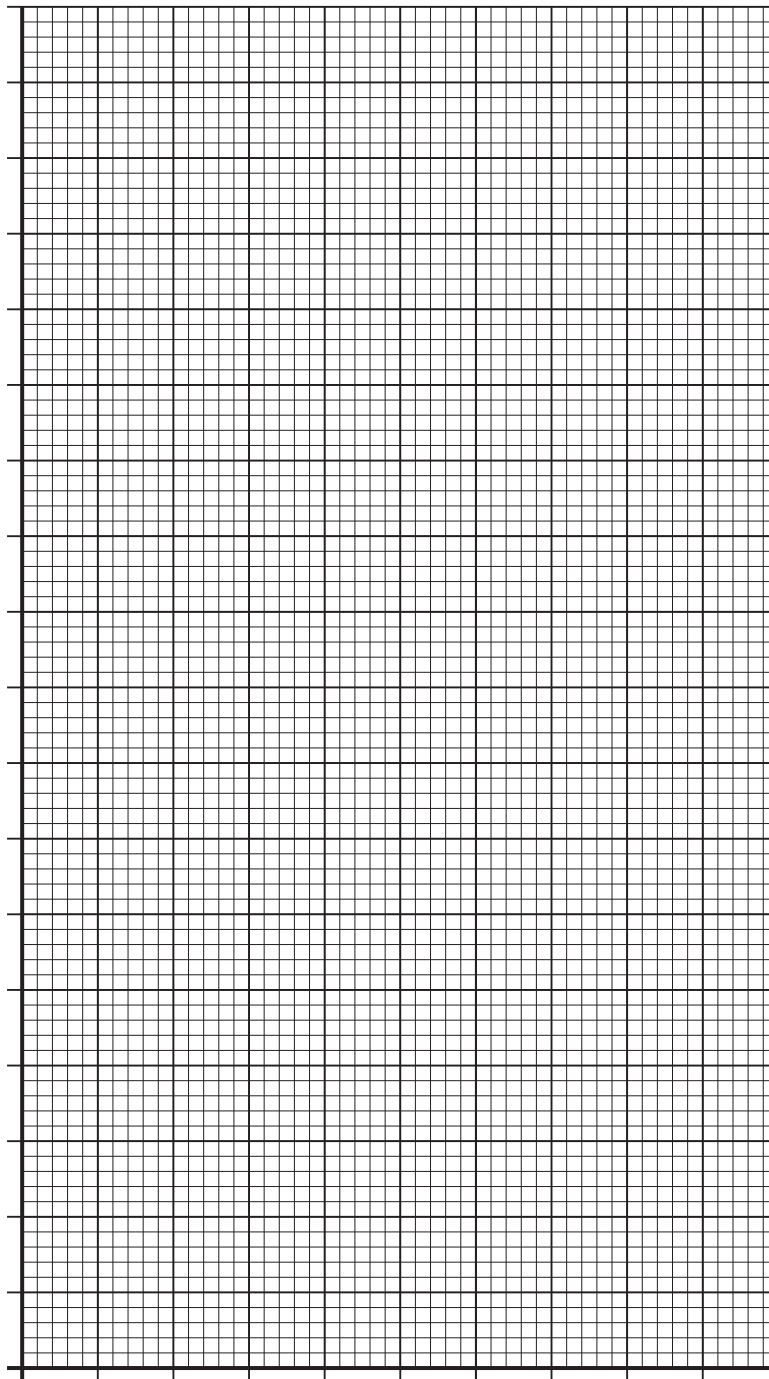

7. (a) (continued)

(ii) Use your graph to determine the charge stored on the capacitor when the distance between plate X and plate Y is 25 mm.

1

(b) Suggest two ways in which the experimental procedure could be improved.

2



[Turn over for next question

DO NOT WRITE ON THIS PAGE



* X 8 5 7 7 5 0 1 2 5 *

8. A set of hair straighteners contain a pair of titanium plates that are heated.

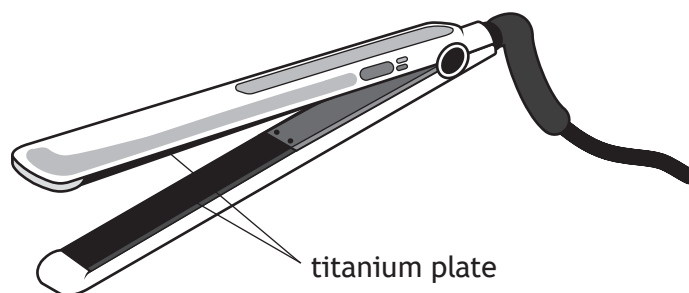

(a) One of the titanium plates has a mass of 1.90×10^{-2} kg.

The titanium plate is at an initial temperature of $25\text{ }^{\circ}\text{C}$. The hair straighteners are switched on and the titanium plate reaches a temperature of $235\text{ }^{\circ}\text{C}$.

The titanium plate has a specific heat capacity of $532\text{ J kg}^{-1}\text{ }^{\circ}\text{C}^{-1}$.

(i) Calculate the minimum energy required to raise the temperature of the titanium plate from $25\text{ }^{\circ}\text{C}$ to $235\text{ }^{\circ}\text{C}$.

3

Space for working and answer

(ii) Explain why the energy supplied to the titanium plate is greater than the heat energy gained by the plate.

1



8. (continued)

(b) The titanium plates are now replaced with ceramic plates.

Suggest **two** reasons why the time taken to heat the ceramic plates from 25 °C to 235 °C is different to the time taken to heat the titanium plates from 25 °C to 235 °C.

2

[Turn over



9. An aircraft is flying at high altitude.

(a) During the flight the pressure of the air inside the aircraft is reduced.

(i) State what is meant by the term *pressure*.

1

(ii) During the flight a passenger notices that the volume of a crisp packet is greater than it was at take-off.

At take-off the pressure of the gas inside the crisp packet was 101 kPa and the volume of gas in the crisp packet was $2.3 \times 10^{-3} \text{ m}^3$.

During the flight the pressure of the gas inside the crisp packet is 92 kPa.

The temperature of the gas inside the crisp packet remains constant.

Calculate the volume of the gas inside the crisp packet at a pressure of 92 kPa.

3

Space for working and answer

(iii) Describe how the kinetic model accounts for the pressure of the gas inside the crisp packet.

1



9. (continued)

- (b) Flying at high altitude increases the exposure of passengers and crew to radiation.

The graph shows how altitude affects the equivalent dose rate received by the passengers and crew on the aircraft.

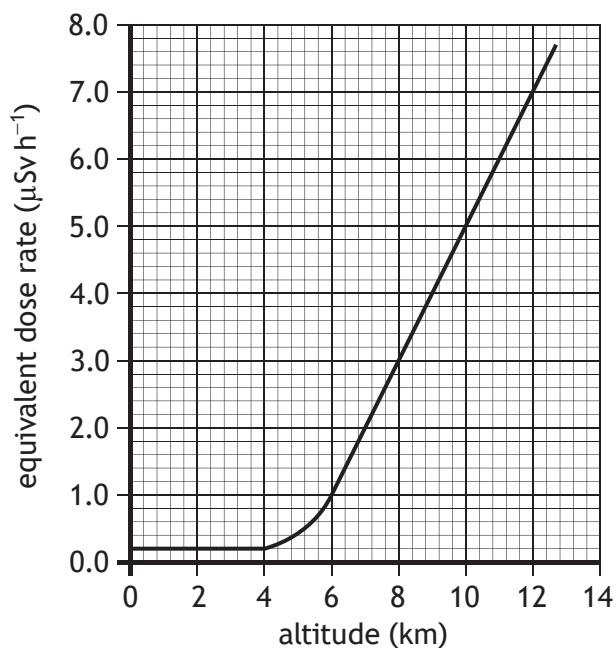

The aircraft flies at an altitude of 11 km for 3.5 hours.

Calculate the equivalent dose received by a crew member during this time.

3

Space for working and answer



* X 8 5 7 7 5 0 1 2 9 *

10. Some cars have parking sensors that emit pulses of ultrasound.

Ultrasound is high frequency sound waves. The emitted sound waves reflect from objects and are detected by sensors on the car.

During testing, a stationary car emits a sound wave with a frequency of 48 000 Hz. The wave reflects from a wall and is detected by the sensors on the car.

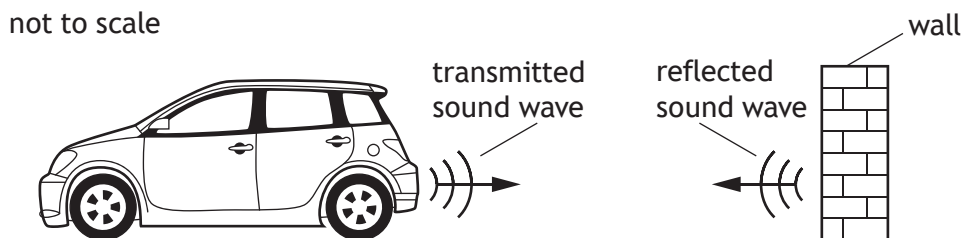

(a) The time taken between the sound wave being emitted and detected by the car is 0.015 s.

Determine the distance between the car and the wall.

4

Space for working and answer

10. (continued)

- (b) The system in the car is now adjusted to emit sound waves with a different frequency.

An oscilloscope connected to the system displays the following trace for the sound waves emitted by the car.

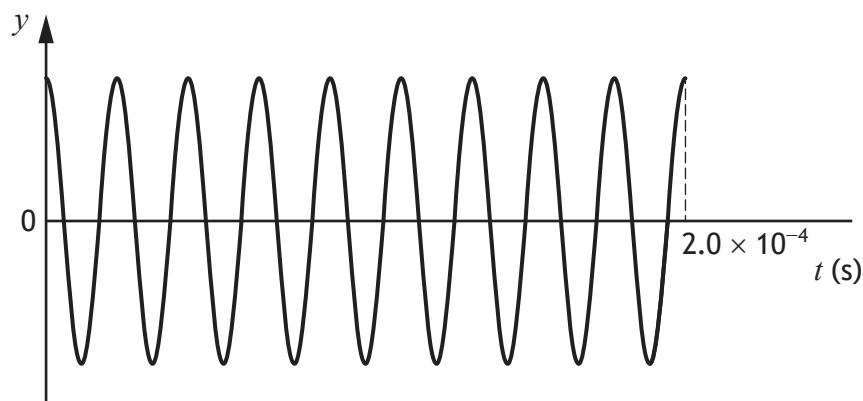

- (i) Show that the frequency of this sound wave is 45 000 Hz.

2

Space for working and answer

- (ii) Explain why the time taken between this sound wave being emitted and detected is also 0.015 s.

1

[Turn over



11. The diagram shows the electromagnetic spectrum in order of increasing wavelength.

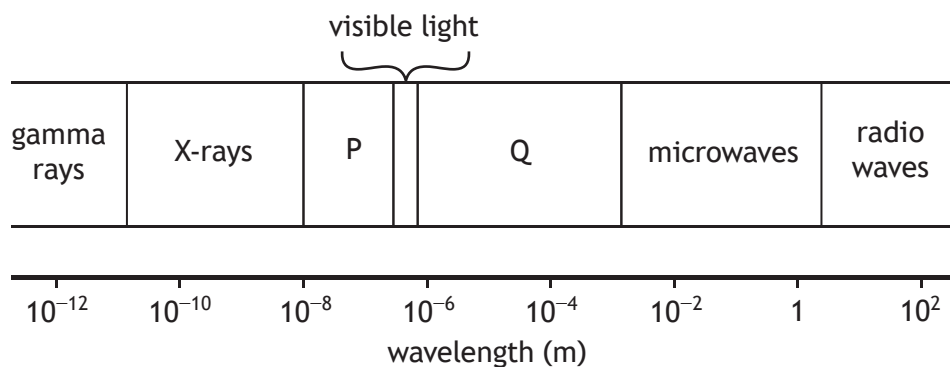

The names of two parts of the spectrum P and Q have been omitted.

- (a) State the names of parts P and Q.

1

P:

Q:

- (b) State which part of the electromagnetic spectrum experiences the greatest amount of diffraction.

Justify your answer.

2



* X 8 5 7 7 5 0 1 3 2 *

11. (continued)

(c) Electromagnetic radiation has many applications in everyday life.

- (i) Wireless headphones receive electromagnetic waves with a frequency of 2.42 GHz from an audio device.



(A) Show that the wavelength of these waves is 0.12 m.

2

Space for working and answer

(B) Identify the part of the electromagnetic spectrum that these waves belong to.

1

[Turn over



11. (c) (continued)

- (ii) X-rays are used in dental procedures to examine the condition of a patient's teeth.



During this procedure the patient's head is exposed to X-rays.

The mass of the patient's head is 4.5 kg.

The patient's head receives an absorbed dose of $5.0 \mu\text{Gy}$ from the X-rays.

- (A) Calculate the energy of the radiation absorbed by the patient's head.

3

Space for working and answer

- (B) Calculate the equivalent dose received by the patient's head.

3

Space for working and answer



* X 8 5 7 7 5 0 1 3 4 *

[Turn over for next question

DO NOT WRITE ON THIS PAGE



* X 8 5 7 7 5 0 1 3 5 *

12. The use of analogies from everyday life can help improve the understanding of physics concepts.

Rows of students with arms linked together moving from a smooth pavement to sand can be used as an analogy for the refraction of light.

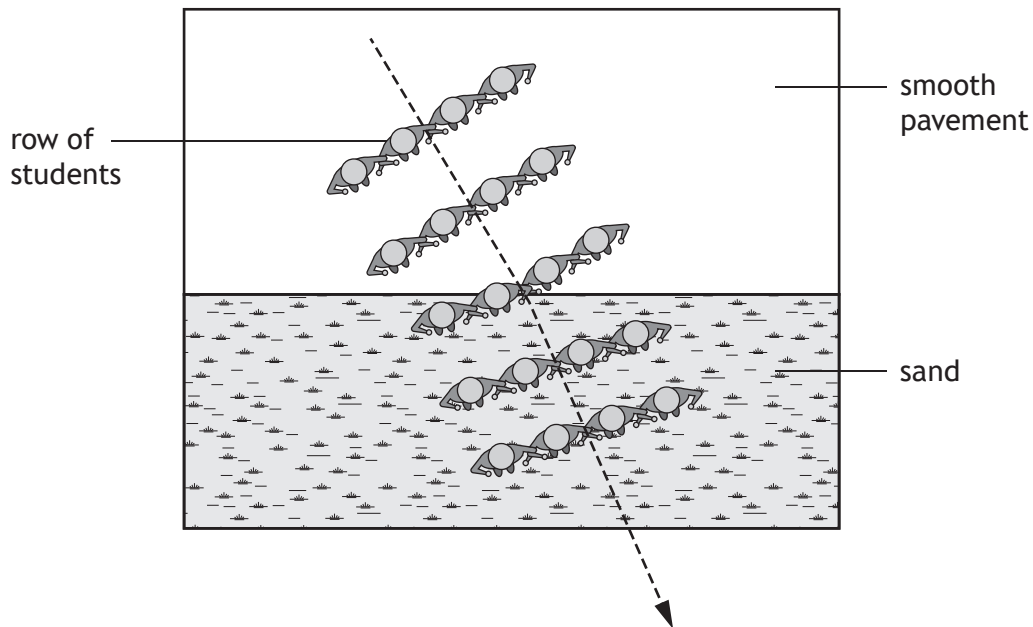

Using your knowledge of physics, comment on this analogy.

3

DO NOT
WRITE IN
THIS
MARGIN

12. (continued)



[BLANK PAGE]

DO NOT WRITE ON THIS PAGE



* X 8 5 7 7 5 0 1 3 8 *

13. An experiment is carried out, using the apparatus shown, to investigate the radiation emitted from different radioactive sources.

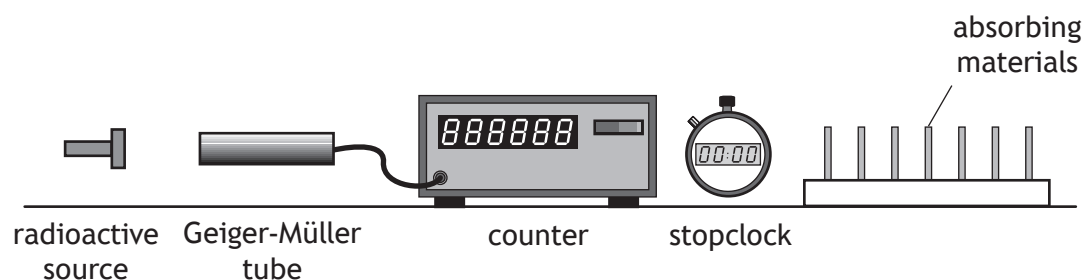

Different absorbing materials are placed, in turn, between the radioactive source and the Geiger-Müller tube, and the count rate is determined.

This procedure is repeated for each radioactive source.

The results are shown in the table.

Radioactive source	Count rate (counts per minute)			
	No absorbing material	Sheet of paper	3 mm thickness of aluminium	8 mm thickness of lead
X	540	542	539	380
Y	823	350	354	171
Z	652	649	12	14

- (a) One of the sources emits beta radiation only, one emits gamma radiation only, and one emits both alpha and gamma radiation.

State which source, X, Y or Z, emits both alpha and gamma radiation.

Justify your answer.

3



13. (continued)

- (b) A second experiment is carried out to investigate the ionising effect of radiation.

A radioactive source is held close to a spark counter. The spark counter consists of a metal wire connected to a microammeter and a high voltage power supply as shown.

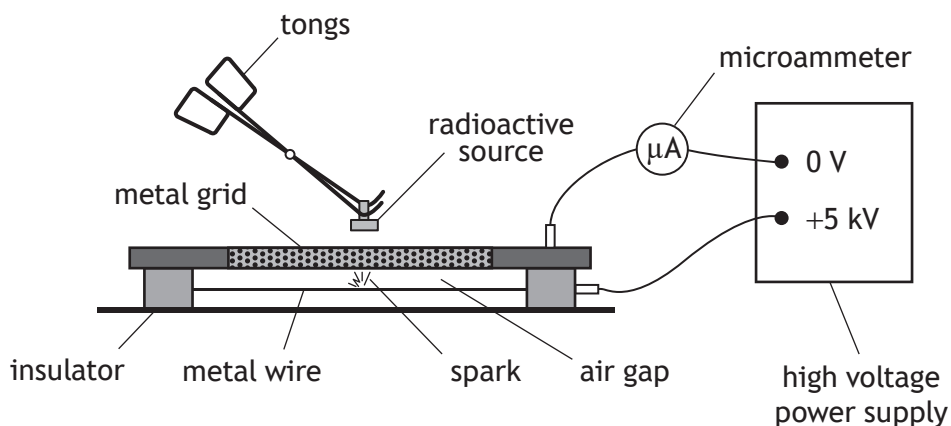

A radioactive source is placed close to the metal grid.

Radiation from the source ionises the air between the metal wire and the grid. Sparks are produced between the wire and the grid.

- (i) State what is meant by the term *ionisation*.

1



13. (b) (continued)

- (ii) The radioactive source used in this experiment emits alpha and gamma radiation.

The source is placed at different distances above the metal grid and the sparks produced are observed.

The results are shown in the table below.

Distance between the source and metal grid (mm)	Observation
10	continuous sparking
30	few sparks
60	no sparks

Using information from the table, state which type of radiation emitted from the source is causing the air between the wire and metal grid to be ionised.

You must justify your answer.

2

- (iii) The radioactive source is now placed at a fixed height above the metal grid.

In a time of one minute, 96 sparks are observed and the average reading on the ammeter is $0.12 \mu\text{A}$.

Determine the average charge transferred between the wire and the grid during each spark.

4

Space for working and answer



14. Iodine-125 is a radioactive substance used to treat cancer.

A sealed capsule containing iodine-125 is implanted inside a patient, next to the cancer cells.

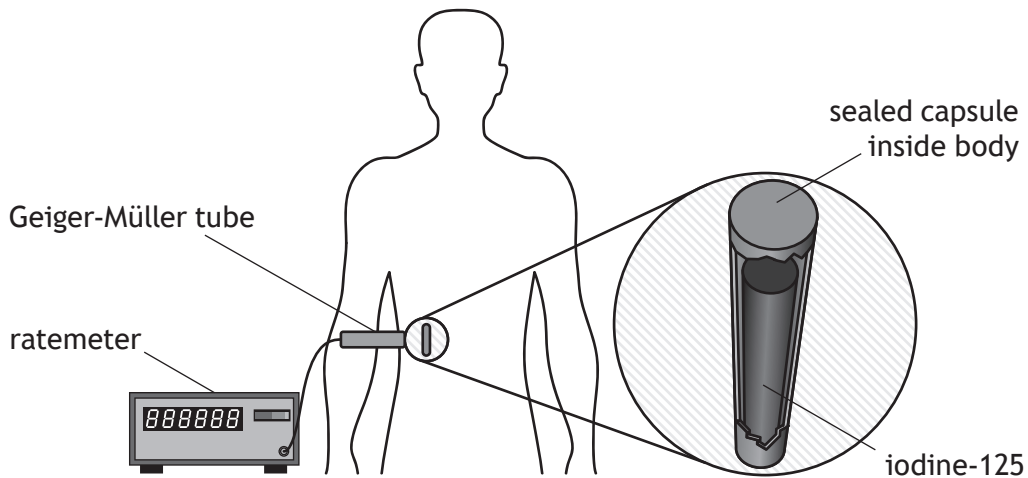

Gamma rays emitted by the iodine-125 damage the cancer cells.

A Geiger-Müller tube and ratemeter are used to measure the count rate from the iodine-125.

Measurements of the count rate are taken at regular time intervals.

These measurements are used to produce a graph showing how the corrected count rate varies with the number of days after implant.

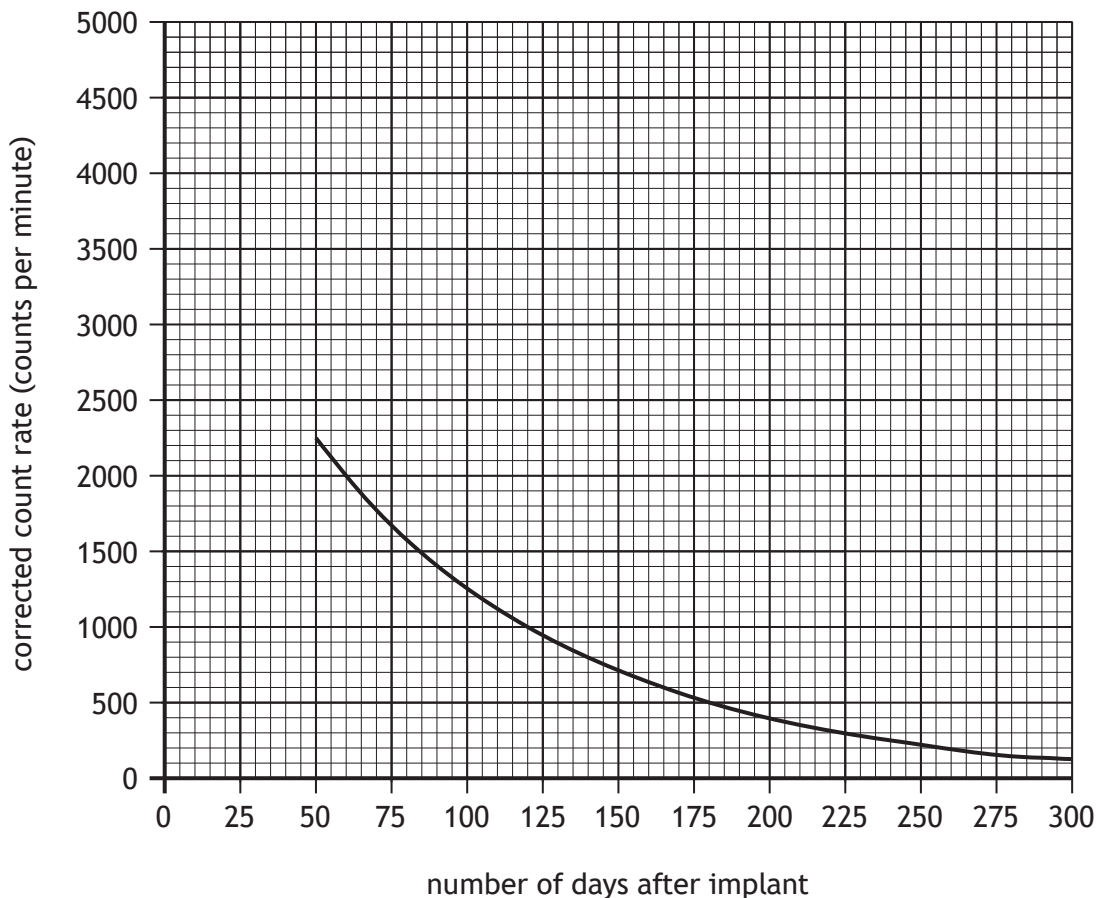

14. (continued)

MARKS
DO NOT
WRITE IN
THIS
MARGIN

(a) (i) State the additional measurement that must have been made in order to determine the corrected count rate.

1

(ii) Using the graph, determine the half-life of iodine-125.

1

(iii) Determine the time it takes for the corrected count rate to reduce to one eighth of its initial value.

2

Space for working and answer

(iv) Determine the initial corrected count rate of iodine-125 at the time it was implanted inside the patient.

1

(b) State one other use of nuclear radiation.

1

[END OF QUESTION PAPER]



* X 8 5 7 7 5 0 1 4 3 *

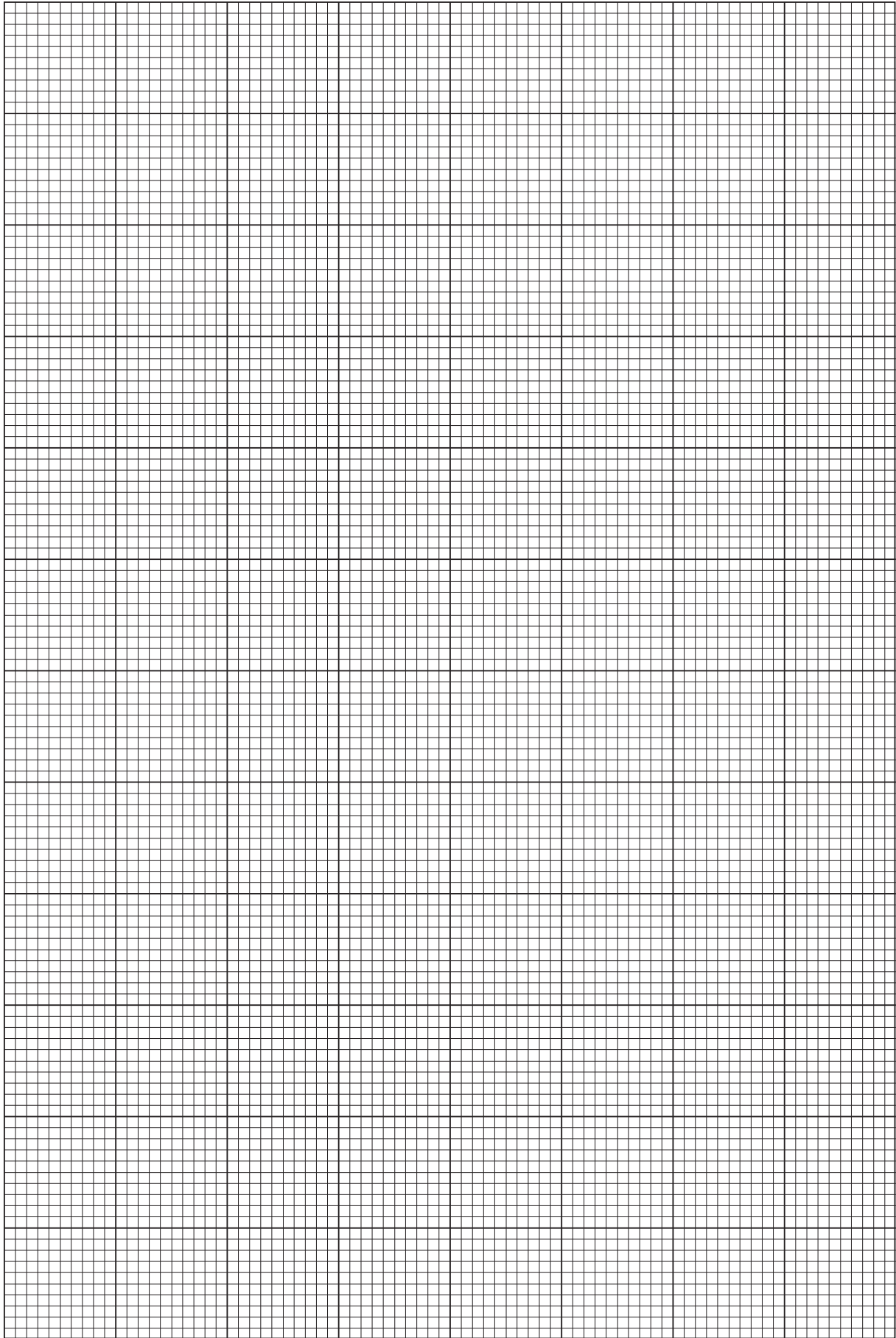

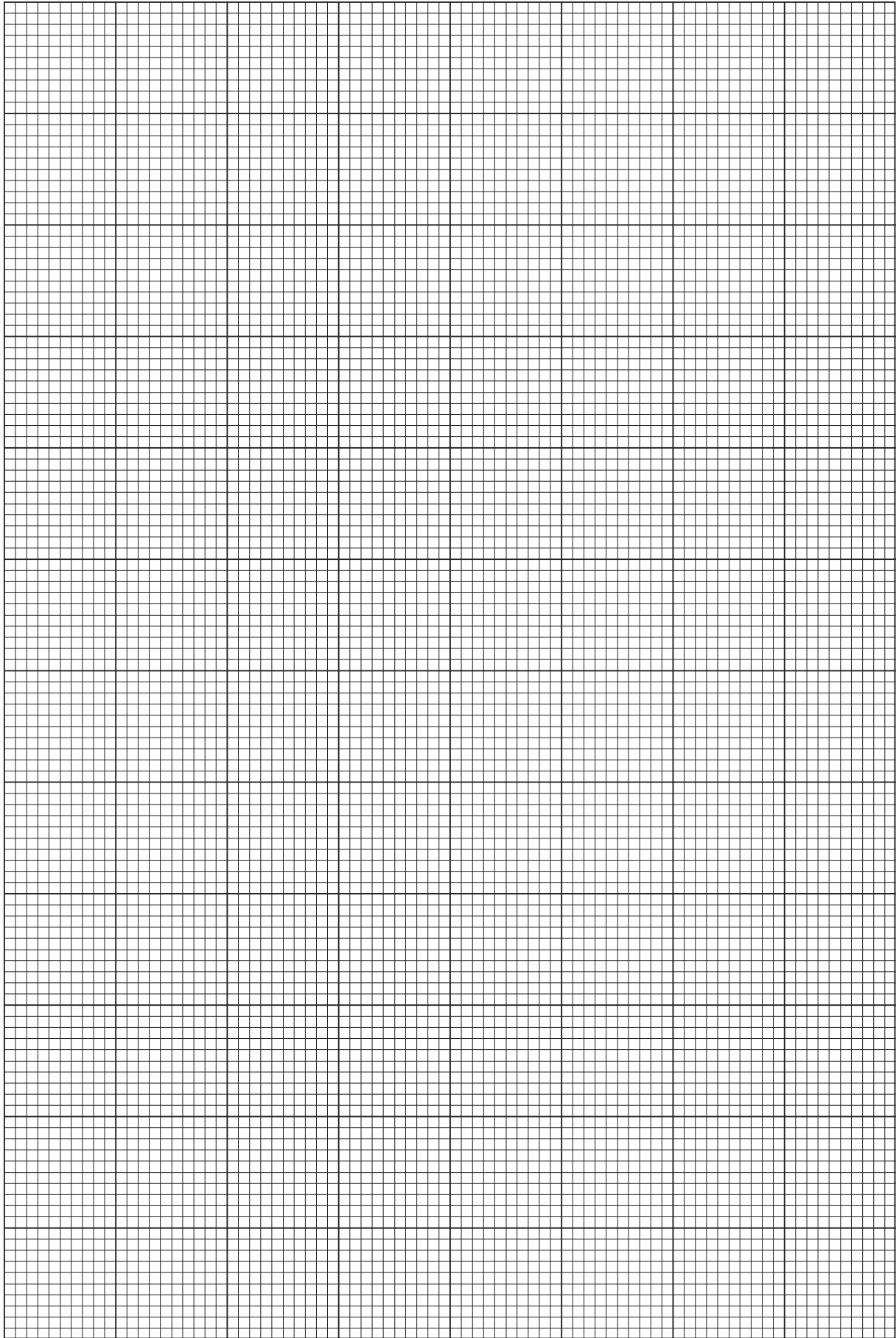

ADDITIONAL SPACE FOR ANSWERS AND ROUGH WORK

Additional diagram for use with question 2 (a)



Additional graph for use with question 2 (b) (ii)



ADDITIONAL SPACE FOR ANSWERS AND ROUGH WORK

Additional graph paper for use with question 7 (a) (i)

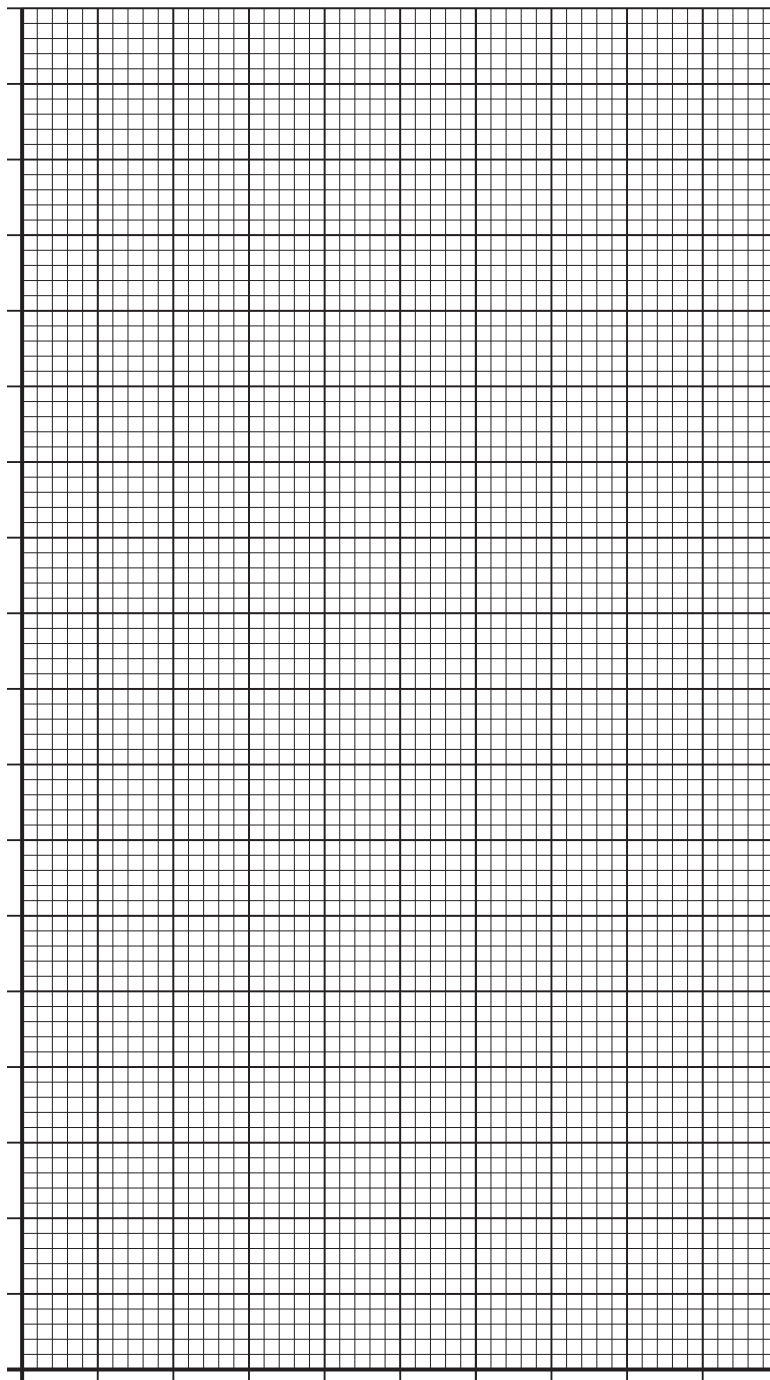

MARKS DO NOT
WRITE IN
THIS
MARGIN

ADDITIONAL SPACE FOR ANSWERS AND ROUGH WORK



MARKS DO NOT
WRITE IN
THIS
MARGIN

ADDITIONAL SPACE FOR ANSWERS AND ROUGH WORK



[BLANK PAGE]

DO NOT WRITE ON THIS PAGE



* X 8 5 7 7 5 0 1 5 0 *

[BLANK PAGE]

DO NOT WRITE ON THIS PAGE



[BLANK PAGE]

DO NOT WRITE ON THIS PAGE

Acknowledgement of copyright

- Question 11 (c) (i) Image by Sandeep Singh is adapted from pexels.com,
<https://www.pexels.com/photo/white-apple-earpods-on-red-surface-7156886/>
- Question 11 (c) (ii) Roman Zaiets/shutterstock.com

