

FOR OFFICIAL USE



National
Qualifications
2019

Mark

X860/75/01

Practical Electronics

FRIDAY, 24 MAY

9:00 AM – 10:00 AM



* X 8 6 0 7 5 0 1 *

Fill in these boxes and read what is printed below.

Full name of centre

Town

Forename(s)

Surname

Number of seat

Date of birth

Day

Month

Year

Scottish candidate number

Total marks — 60

Attempt ALL questions.

Write your answers clearly in the spaces provided in this booklet. Additional space for answers is provided at the end of this booklet. If you use this space you must clearly identify the question number you are attempting.

Use **blue** or **black** ink.

Before leaving the examination room you must give this booklet to the Invigilator; if you do not, you may lose all the marks for this paper.





* X 8 6 0 7 5 0 1 0 1 *

Total marks — 60
Attempt ALL questions

1. The table below gives information about some circuit components.
 Some of the boxes have been left blank.

(a) Complete the table for the missing entries.

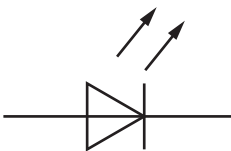
3

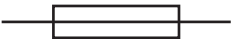
Component name	Symbol	Function
Light emitting diode		Emits light indicating a current flow
MOSFET transistor		
Motor		Converts electrical energy to kinetic energy
		To protect wiring from too much current

1. (continued)

(b) A technician is examining the circuit board shown below when a fault is discovered.

A resistor with an incorrect value has been used.

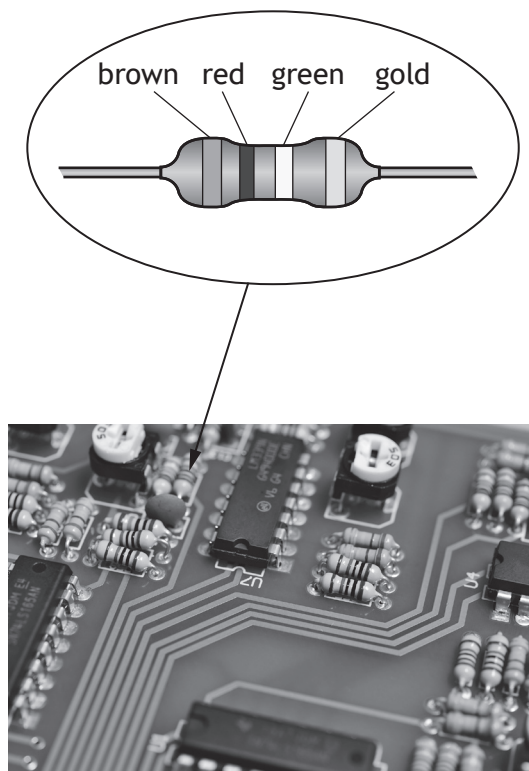

Use the information in the data sheet to answer the questions below.

(i) Determine the resistance of the resistor. 1

(ii) The technician replaces the incorrect component with a resistor of value 600Ω which has a 2% tolerance. Determine the minimum and maximum resistance of the resistor. 2

2. A remote entry system for a block of flats allows a resident to unlock the outside door from inside their flat.

Part of this system is shown in the diagram below.

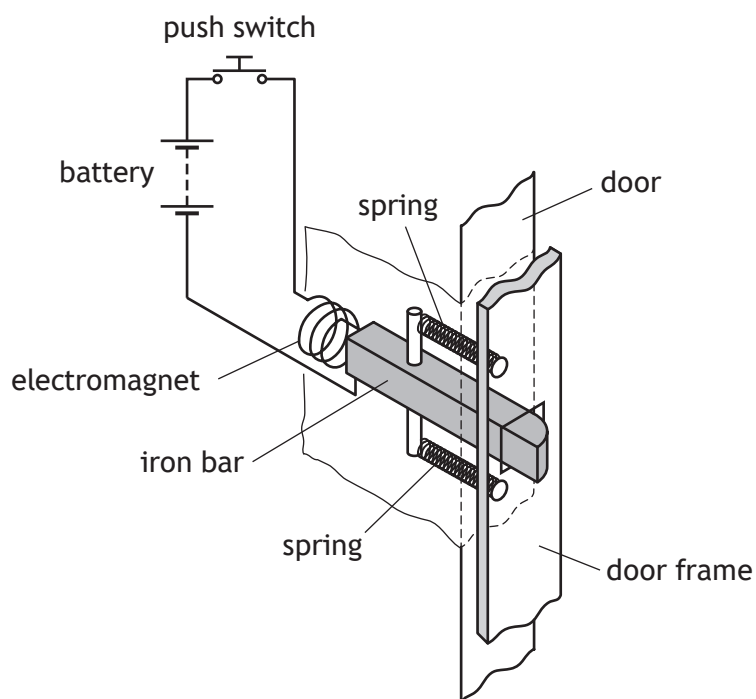

- (a) Explain how this part of the system operates to unlock the door.

2



2. (continued)

- (b) A light dependent resistor and sleeving is connected to a process board by two wires as shown in the picture below.

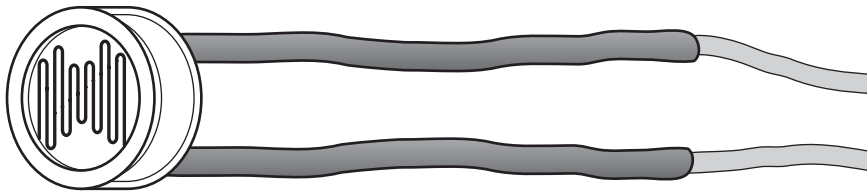

- (i) Name the wiring technique shown.

1

- (ii) State why this technique is used.

1

[Turn over



3. A circuit diagram is shown below.

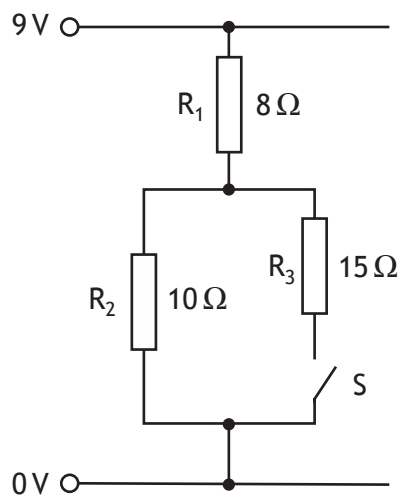

Switch S is open.

(a) (i) Calculate the total resistance of the circuit.

1

Space for working and answer

(ii) Calculate the current in the circuit.

3

Space for working and answer



MARKS

DO NOT
WRITE IN
THIS
MARGIN

3. (a) (continued)

(iii) Calculate the power dissipated in resistor R_1 .

Space for working and answer

3

(b) Switch S is now closed.

Calculate the effective resistance of R_2 and R_3 in parallel.

Space for working and answer

3

[Turn over



* X 8 6 0 7 5 0 1 0 7 *

4. There are many different types of logic gates used in electronic circuits.

(a) Draw the circuit symbol for a NAND gate.

1

(b) The truth table for a logic gate is shown below.

A	B	Output
0	0	1
0	1	0
1	0	0
1	1	0

Name the logic gate that produces this truth table.

1



4. (continued)

Many electronic devices use several logic gates connected to one another.

(c) Complete the truth table for the logic circuit shown below.

3

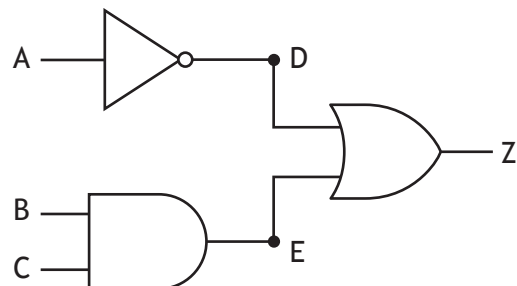

A	B	C	D	E	Z
0	0	0			
0	0	1			
0	1	0			
0	1	1			
1	0	0			
1	0	1			
1	1	0			
1	1	1			

(An additional truth table, if required, can be found on page 20)

[Turn over



5. A student wants to measure the **voltage** across a component in a circuit and sets up the multimeter as shown below.

(a) Identify the two errors the student has made.

2

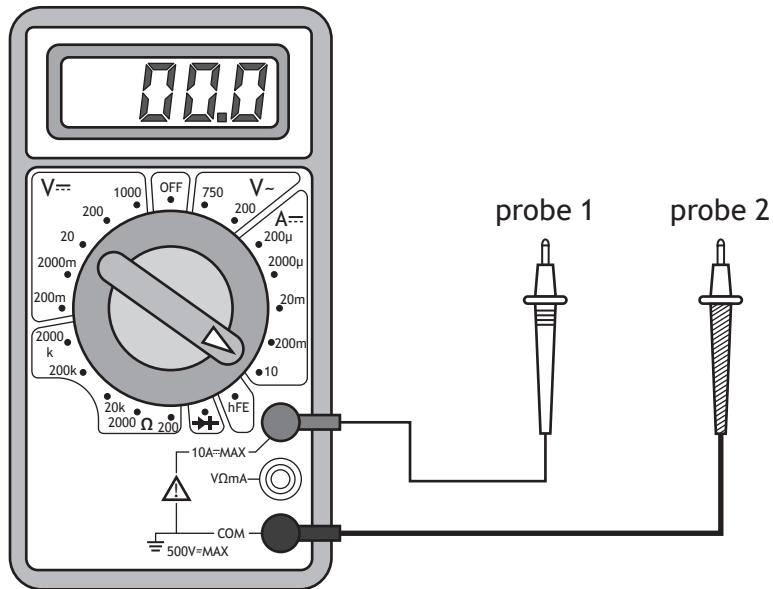

Error 1:

Error 2:

MARKS

DO NOT
WRITE IN
THIS
MARGIN

5. (continued)

(b) The student is given a resistor with no colour markings.

Describe how the student would set up and use a multimeter to accurately measure the resistance of the resistor.

3

[Turn over



* X 8 6 0 7 5 0 1 1 1 *

6. An oscilloscope is connected to show the output trace from a signal generator. The trace is shown on the screen. The Y-gain and timebase settings are also shown.

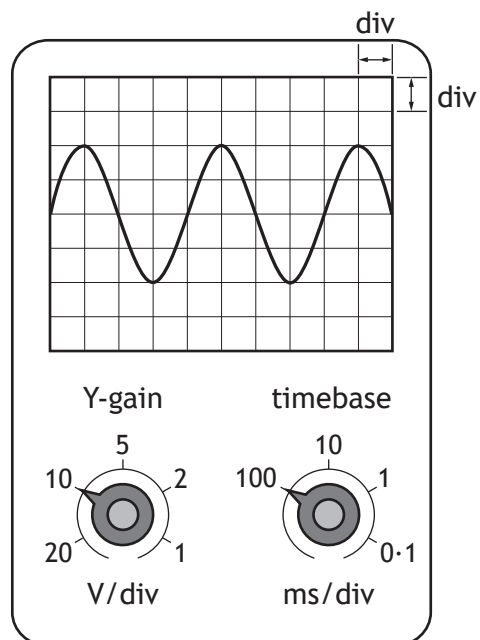

- (a) Determine the frequency of the signal.
Space for working and answer

3

6. (continued)

The output from the signal generator was changed to produce the trace shown below.

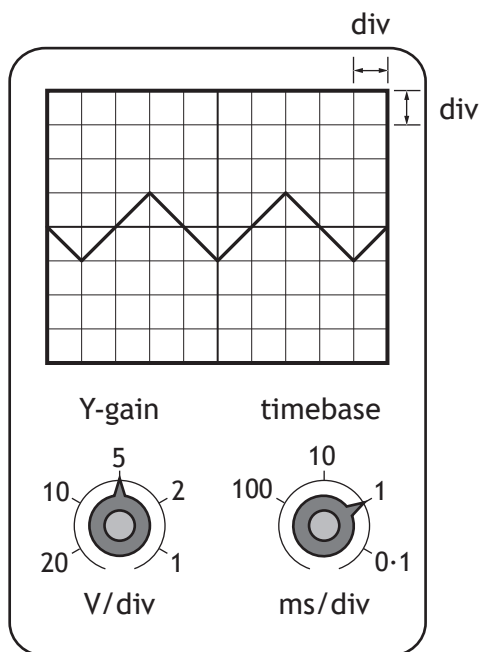

(b) State whether the signal is analogue or digital.

1

[Turn over

7. A low temperature warning system is controlled using a LM741 comparator circuit as shown in the simulation below.

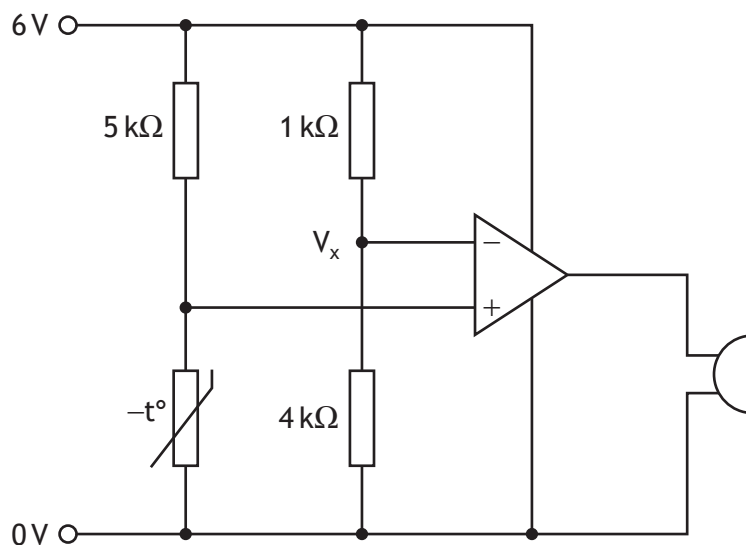

- (a) Calculate the reference voltage V_x .

3

Space for working and answer

- (b) State the resistance of the thermistor when the voltage across it is equal to the reference voltage V_x .

1

- (c) Describe how this circuit works.

3



8. A student simulated the circuit shown below.

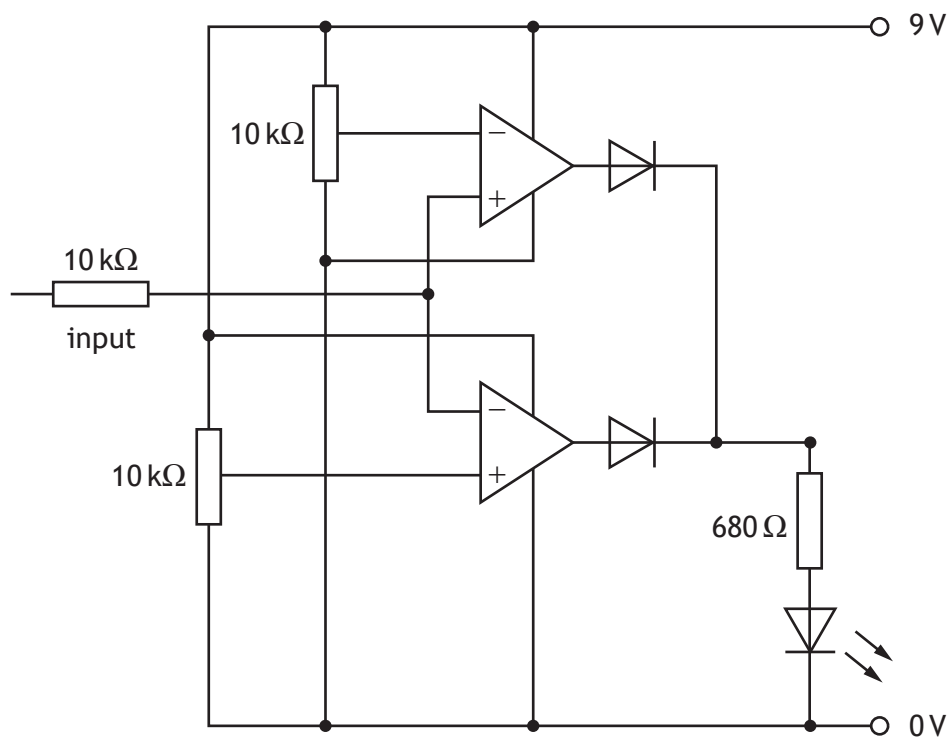

(a) Complete the following table by giving **three** pre-power up checks for this circuit.

3

Pre-power up checklist
Check both IC's orientation

[Turn over



8. (continued)

(b) A student also produced a simulation of a circuit to logic test a single AND gate using a LED as the output device.

However the simulation does not work as specified.

Identify **the four** errors in the simulation below.

4

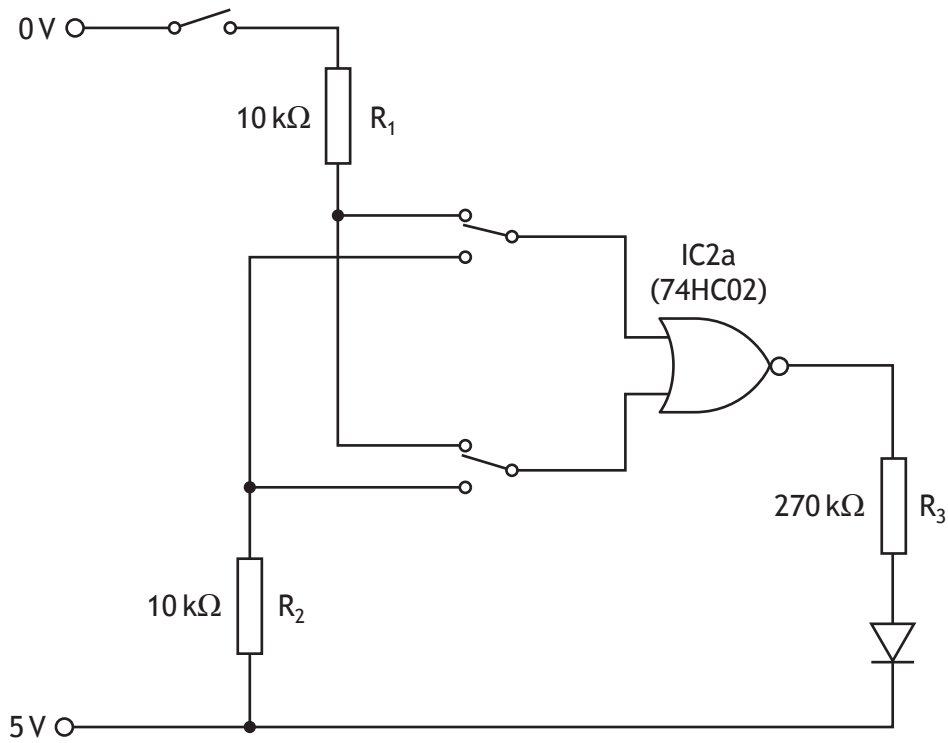

Error 1:

Error 2:

Error 3:

Error 4:



9. A security system for a house requires a lamp and an alarm to turn on when movement is detected outside the house. The security system only needs to operate at night.

Selecting from the elements given below, draw a block diagram of an electronic solution for the security system.

On your diagram, clearly indicate the input, process and output sections of your solution.

6

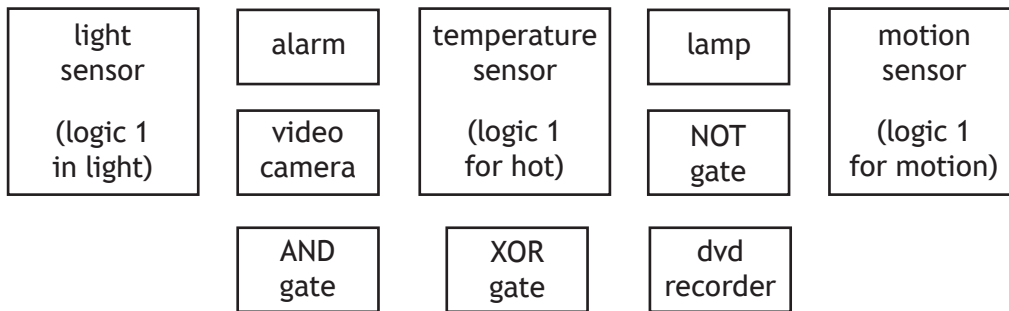

* X 8 6 0 7 5 0 1 1 7 *

10. The stripboard plan shows a **component (top) view** of a circuit with the following layout.

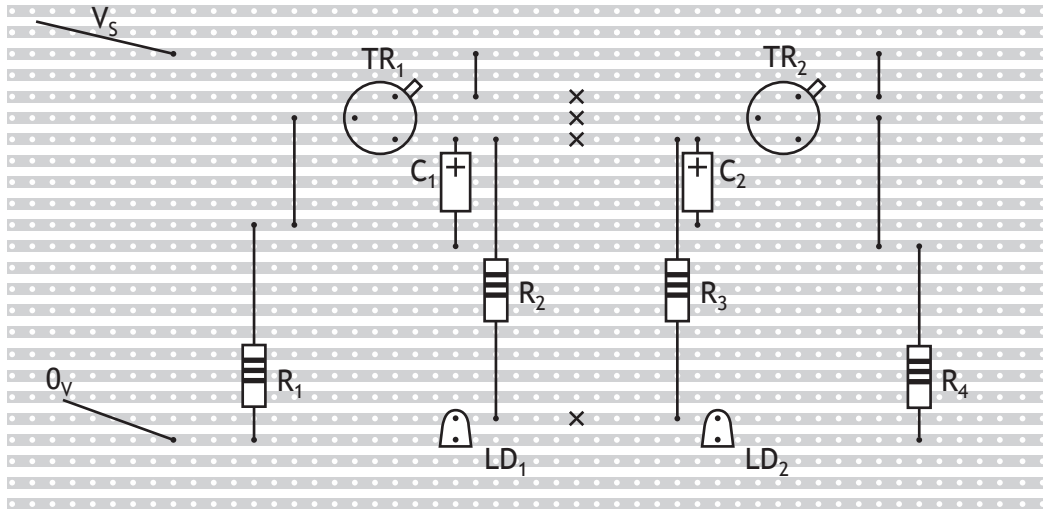

Component data

\$R_1\$ and \$R_4\$ – carbon film 2K2 0.25W

\$R_2\$ and \$R_3\$ – carbon film 390R 0.25W

\$C_1\$ – 100µF electrolytic capacitor

\$C_2\$ – 100µF electrolytic capacitor

\$LD_1\$ and \$LD_2\$ 5mm standard LED

\$TR_1\$ and \$TR_2\$ – BC179 pnp bipolar transistors

X shows where a track has been cut

\$TR_1\$ and \$TR_2\$ pin connections

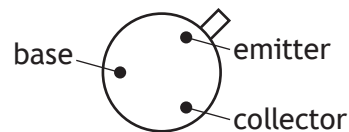

Draw a circuit diagram for this circuit.

Each component must be labelled.

6



10. (continued)

[END OF QUESTION PAPER]



* X 8 6 0 7 5 0 1 1 9 *

ADDITIONAL SPACE FOR ANSWERS

Additional truth table for question 4 (c)

A	B	C	D	E	Z
0	0	0			
0	0	1			
0	1	0			
0	1	1			
1	0	0			
1	0	1			
1	1	0			
1	1	1			



MARKS

DO NOT
WRITE IN
THIS
MARGIN

ADDITIONAL SPACE FOR ANSWERS



* X 8 6 0 7 5 0 1 2 1 *

MARKS

DO NOT
WRITE IN
THIS
MARGIN

ADDITIONAL SPACE FOR ANSWERS



* X 8 6 0 7 5 0 1 2 2 *

[BLANK PAGE]

DO NOT WRITE ON THIS PAGE



* X 8 6 0 7 5 0 1 2 3 *

[BLANK PAGE]

DO NOT WRITE ON THIS PAGE

Acknowledgement of copyright

Question 1(b) Artit Thongchuea/shutterstock.com



* X 8 6 0 7 5 0 1 2 4 *



National
Qualifications
2019

X860/75/11

**Practical Electronics
Data sheet**

FRIDAY, 24 MAY

9:00 AM – 10:00 AM



* X 8 6 0 7 5 1 1 *

Relationships required for National 5 Practical Electronics

$$V = IR$$

$$R_T = R_1 + R_2 + \dots$$

$$\frac{1}{R_T} = \frac{1}{R_1} + \frac{1}{R_2} + \dots$$

$$P = IV$$

$$P = I^2R$$

$$P = \frac{V^2}{R}$$

$$\frac{V_1}{V_2} = \frac{R_1}{R_2}$$

$$V_2 = \frac{R_2}{R_1 + R_2} \times V_s$$

$$f = \frac{1}{T}$$

Resistor colour codes

4-band resistor

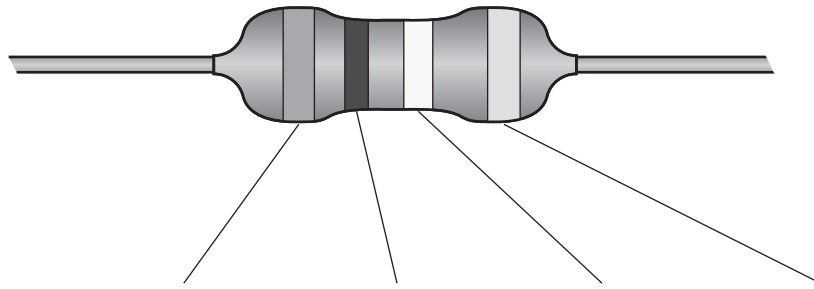

Colour	1st band value	2nd band value	Multiplier	Tolerances
Black	0	0	× 1	
Brown	1	1	× 10	±1%
Red	2	2	× 100	±2%
Orange	3	3	× 1000	±3%
Yellow	4	4	× 10000	±4%
Green	5	5	× 100000	±0.5%
Blue	6	6	× 1000000	±0.25%
Violet	7	7	× 10000000	±0.10%
Grey	8	8	× 100000000	±0.05%
White	9	9	× 1000000000	
Gold			× 0.1	±5%
Silver			× 0.01	±10%
No band				±20%

IC Pinout diagrams

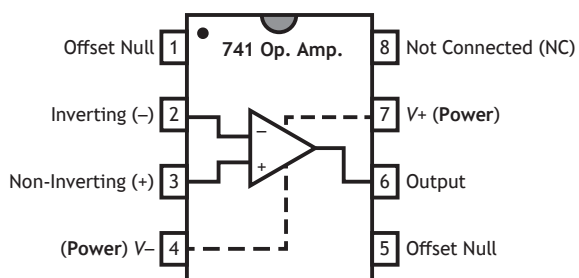

741 Op-amp

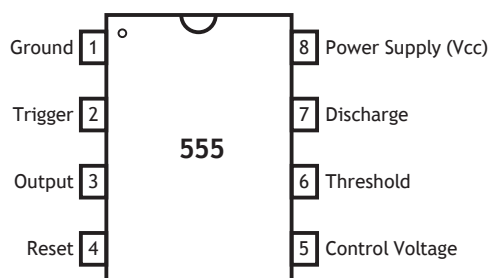

555 timer

[Turn over

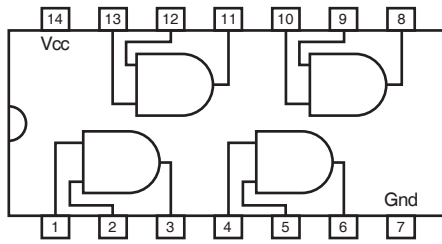

7408 Quad 2 input
AND Gates

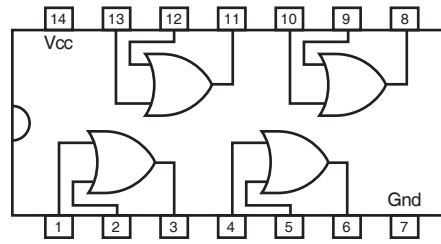

7432 Quad 2 input
OR Gates

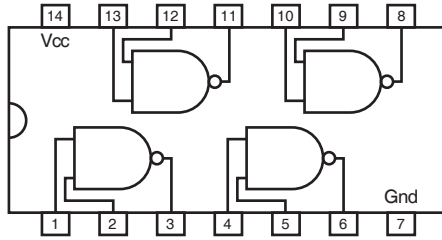

7400 Quad 2 input
NAND Gates

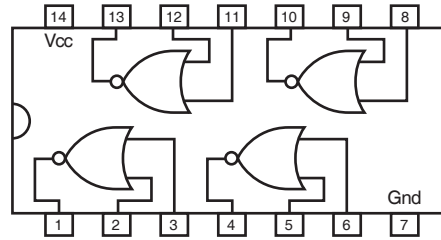

7402 Quad 2 input
NOR Gates

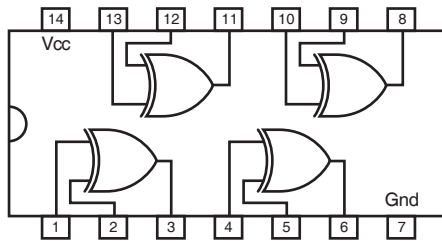

7486 Quad 2 input
XOR Gates

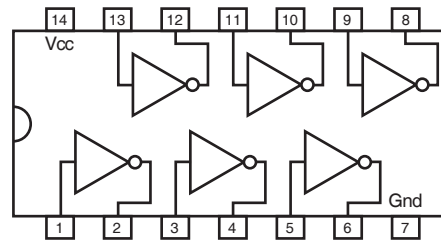

7404 Hex NOT Gates
(Inverters)

[END OF DATA SHEET]