

FOR OFFICIAL USE



--	--	--	--	--	--

National  
Qualifications  
2021 ASSESSMENT RESOURCE

Mark

--

**X823/77/01**

**Engineering Science  
Answer booklet**



\* X 8 2 3 7 7 0 1 \*

Fill in these boxes and read what is printed below.

Full name of centre

--

Town

--

Forename(s)

--

Surname

--

Number of seat

--

Date of birth

Day

--	--

Month

--	--

Year

--	--

Scottish candidate number

--	--	--	--	--	--	--	--	--	--

Write your answers clearly in this answer booklet. You must clearly identify in the margin the question number you are attempting.

**Worksheets for questions 2 (b), 7 (a) and (b), 8 (e) and 9 (g) are included. Write your answers to these questions clearly in the spaces provided.**

Use **blue** or **black** ink.

Before leaving the examination room you must give this booklet to the Invigilator; if you do not, you may lose all the marks for this paper.



\* X 8 2 3 7 7 0 1 0 1 \*



Worksheet for question 2 (b)

Activity	Duration (weeks)	Precedents
A	3	----
B	2	----
C	4	----
D	5	A,B
E	7	A,C
F	1	D,E
G	1	F

Key

EST = earliest possible start time  
 LST = latest possible start time  
 EFT = earliest possible finish time  
 LFT = latest possible finish time  
 A = activity  
 DUR = duration  
 F = float

EST	A	EFT
		F
LST	DUR	LFT

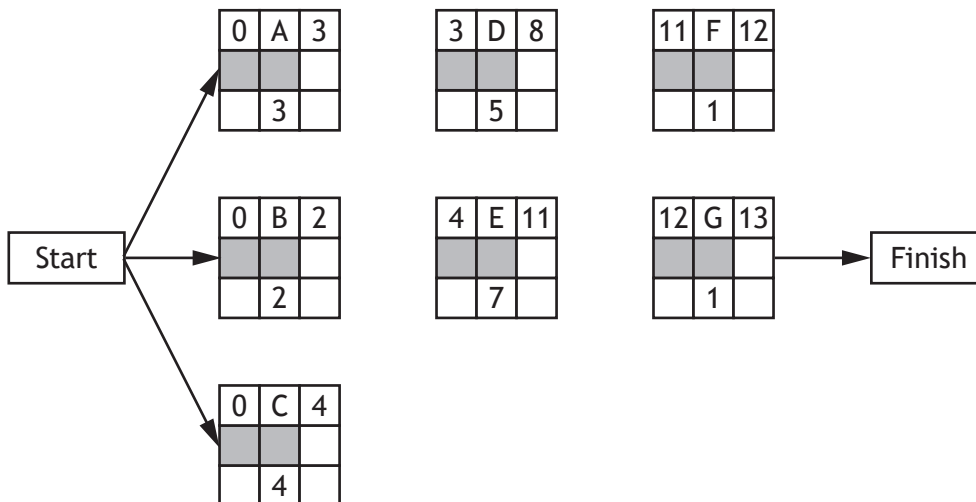

Critical path \_\_\_\_\_



Worksheet for question 7 (a)

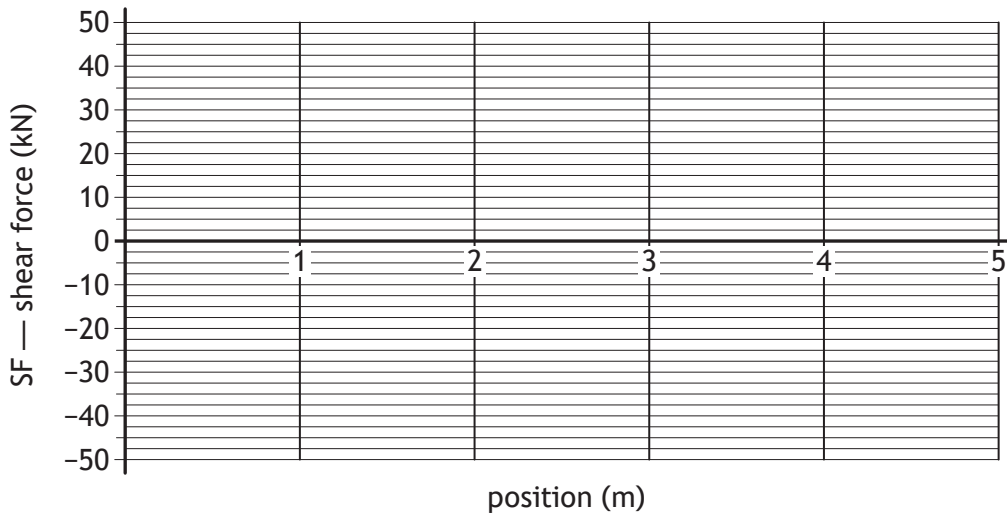

Worksheet for question 7 (b)

	Position							From left-hand end (A)
	0	1	2	2.5	3	4	5	m
<b>BM</b>	0						0	kNm

[Turn over



\* X 8 2 3 7 7 0 1 0 3 \*

Worksheet for question 8 (e)

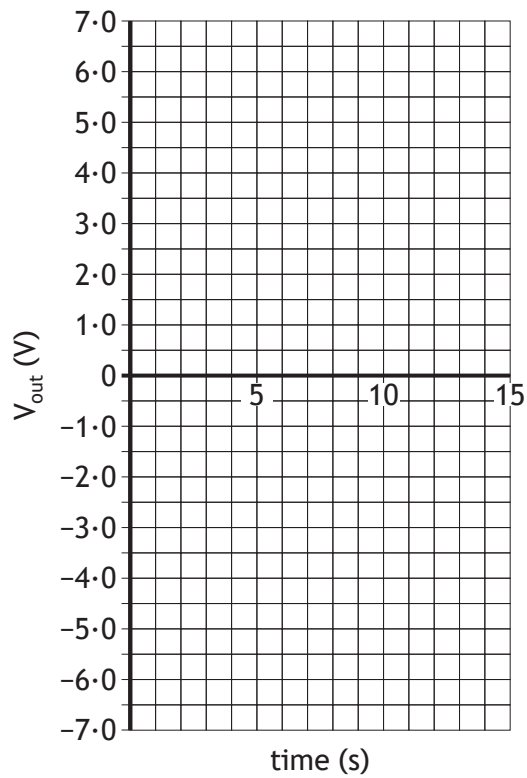
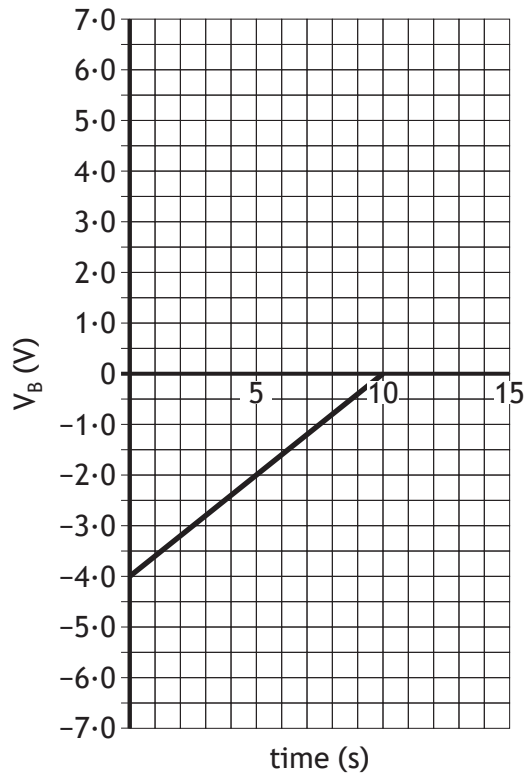
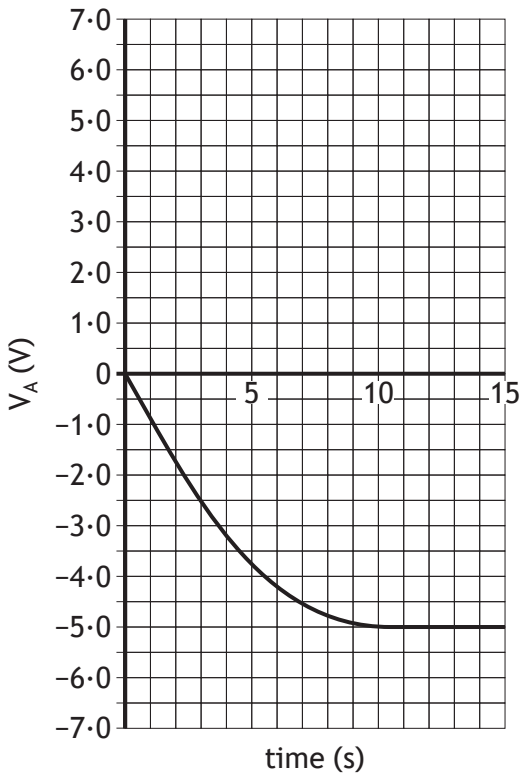

\* X 8 2 3 7 7 0 1 0 4 \*

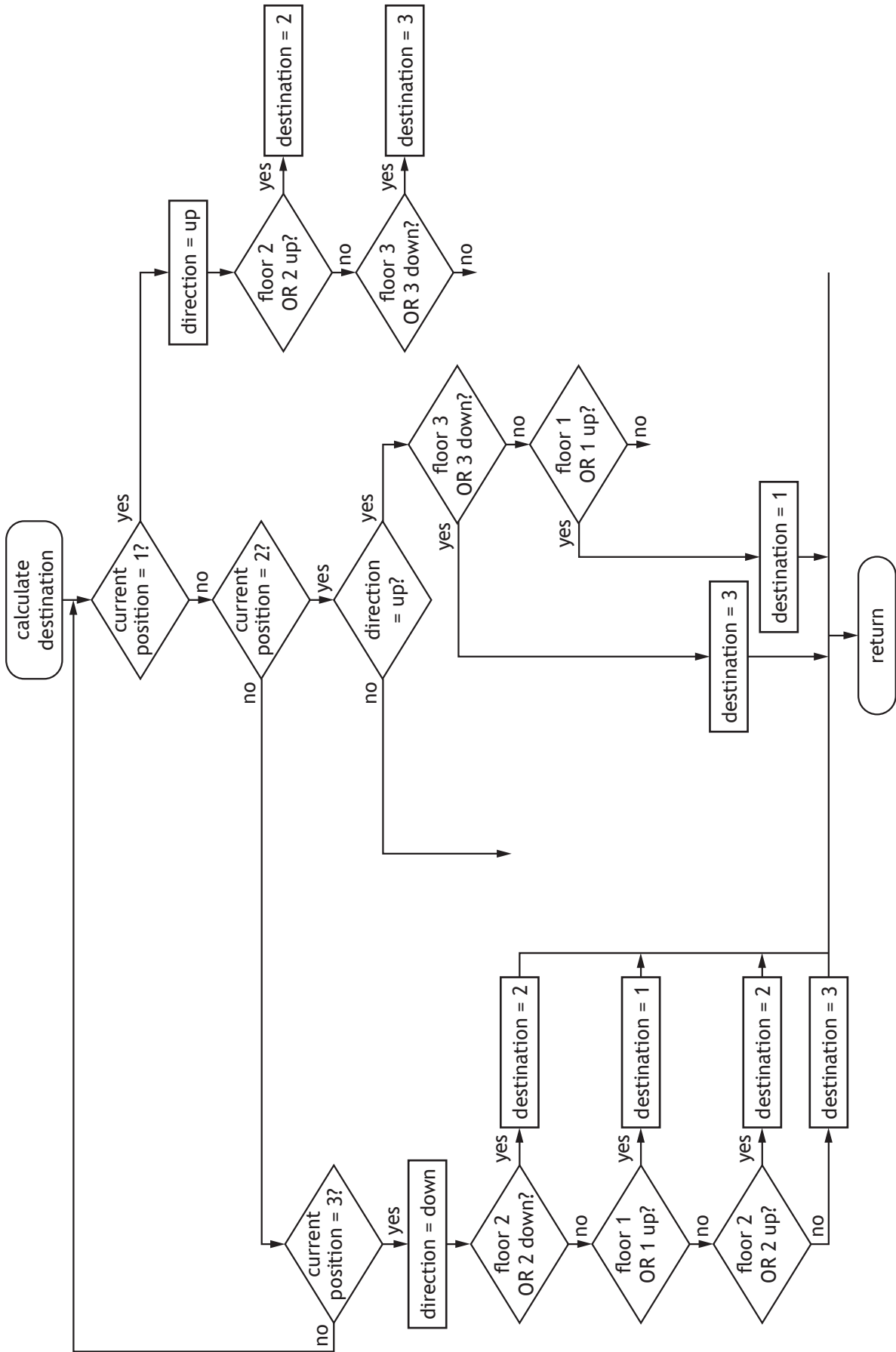

\* X 8 2 3 7 7 0 1 0 5 \*

ENTER  
NUMBER  
OF  
QUESTION

DO NOT  
WRITE IN  
THIS  
MARGIN



\* X 8 2 3 7 7 0 1 0 6 \*

ENTER  
NUMBER  
OF  
QUESTION

DO NOT  
WRITE IN  
THIS  
MARGIN



\* X 8 2 3 7 7 0 1 0 7 \*

ENTER  
NUMBER  
OF  
QUESTION

DO NOT  
WRITE IN  
THIS  
MARGIN



\* X 8 2 3 7 7 0 1 0 8 \*



ENTER  
NUMBER  
OF  
QUESTION

DO NOT  
WRITE IN  
THIS  
MARGIN



\* X 8 2 3 7 7 0 1 0 9 \*

ENTER  
NUMBER  
OF  
QUESTION

DO NOT  
WRITE IN  
THIS  
MARGIN



\* X 8 2 3 7 7 0 1 1 0 \*

ENTER  
NUMBER  
OF  
QUESTION

DO NOT  
WRITE IN  
THIS  
MARGIN



\* X 8 2 3 7 7 0 1 1 1 \*

ENTER  
NUMBER  
OF  
QUESTION

DO NOT  
WRITE IN  
THIS  
MARGIN



\* X 8 2 3 7 7 0 1 1 2 \*

ENTER  
NUMBER  
OF  
QUESTION

DO NOT  
WRITE IN  
THIS  
MARGIN



\* X 8 2 3 7 7 0 1 1 3 \*

ENTER  
NUMBER  
OF  
QUESTION

DO NOT  
WRITE IN  
THIS  
MARGIN



\* X 8 2 3 7 7 0 1 1 4 \*

ENTER  
NUMBER  
OF  
QUESTION

DO NOT  
WRITE IN  
THIS  
MARGIN



\* X 8 2 3 7 7 0 1 1 5 \*

ENTER  
NUMBER  
OF  
QUESTION

DO NOT  
WRITE IN  
THIS  
MARGIN



\* X 8 2 3 7 7 0 1 1 6 \*



ENTER  
NUMBER  
OF  
QUESTION

DO NOT  
WRITE IN  
THIS  
MARGIN



\* X 8 2 3 7 7 0 1 1 7 \*

ENTER  
NUMBER  
OF  
QUESTION

DO NOT  
WRITE IN  
THIS  
MARGIN



\* X 8 2 3 7 7 0 1 1 8 \*

ENTER  
NUMBER  
OF  
QUESTION

DO NOT  
WRITE IN  
THIS  
MARGIN



\* X 8 2 3 7 7 0 1 1 9 \*

ENTER  
NUMBER  
OF  
QUESTION

DO NOT  
WRITE IN  
THIS  
MARGIN



\* X 8 2 3 7 7 0 1 2 0 \*

ENTER  
NUMBER  
OF  
QUESTION

DO NOT  
WRITE IN  
THIS  
MARGIN



\* X 8 2 3 7 7 0 1 2 1 \*

ENTER  
NUMBER  
OF  
QUESTION

DO NOT  
WRITE IN  
THIS  
MARGIN



\* X 8 2 3 7 7 0 1 2 2 \*

ENTER  
NUMBER  
OF  
QUESTION

DO NOT  
WRITE IN  
THIS  
MARGIN



\* X 8 2 3 7 7 0 1 2 3 \*

