



---

# National 5 Practical Woodworking

## Practical activity

### Parts and materials: storage box

**Valid for sessions 2024-25, 2025-26, 2026-27 only.**

The information in this publication may be reproduced in support of SQA qualifications only on a non-commercial basis. If it is reproduced, SQA must be clearly acknowledged as the source. If it is to be reproduced for any other purpose, written permission must be obtained from [permissions@sqa.org.uk](mailto:permissions@sqa.org.uk).

This edition: May 2024 (version 1.0)

© Scottish Qualifications Authority 2024

# Contents

Introduction	1
Instructions for teachers and lecturers	2
Questions and answers	5

# Introduction

This document contains information for teachers and lecturers when preparing materials for candidates to use in the National 5 Practical Woodworking practical activity.

The National 5 Practical Woodworking course assessment has an annually issued task for candidates to complete. We publish this on SQA's secure website at the end of October of each academic session and is valid for that academic session only.

To support centres (and to ease the planning of material purchases) we will use the same parts and materials list for three academic sessions.

# Instructions for teachers and lecturers

## storage box

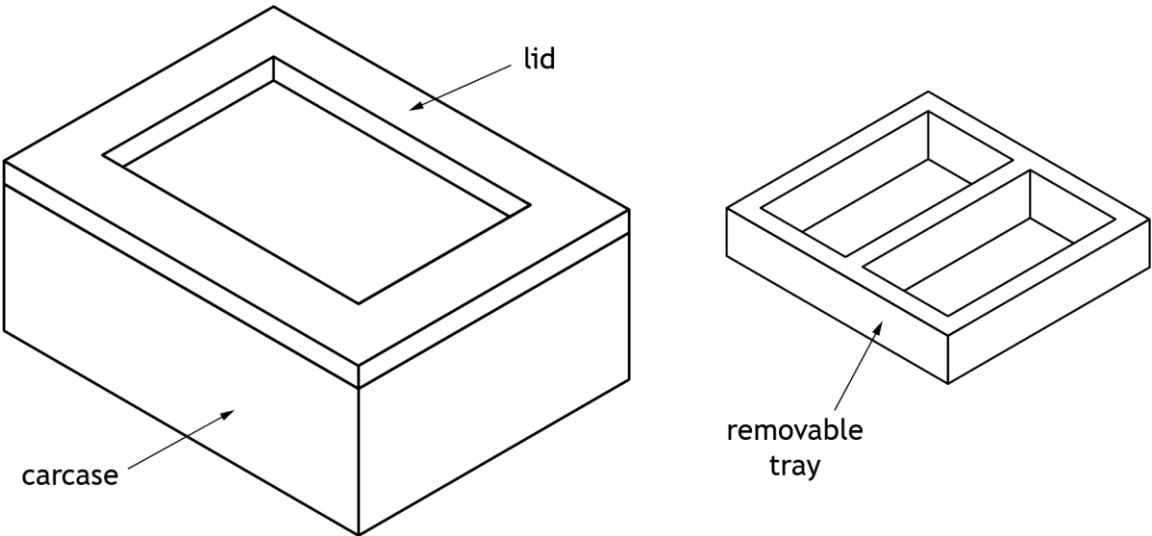

## Storage box

The drawing of the storage box gives no indication of the joints required to complete the lid, the carcass, the tray or the turnery detail. These aspects will change from year to year, sampling jointing and machining exclusively from the National 5 course specification. The turnery will either be incorporated in a decorative feature or a component of the product.

We have provided a generic cutting list below. This allows you to plan the purchase of materials before we publish the detailed drawings for that session's task. The cutting list allows for all combinations of construction over the stated period.

**Note:** To minimise waste, we advise that you **do not cut materials** until we have issued the final cutting list for any given year, as there may be significant changes.

The thickness of all component parts will remain constant throughout the three sessions. However, to allow construction to vary from year to year, there may be some reduction in the length of some parts.

No quantity, length or breadth will increase from the size given in the generic cutting list.

### Generic cutting list

#### Lid

Part	No	Material	Length(mm)	Breadth(mm)	Thickness(mm)
Rails	2	Solid wood	250	35	18
Stiles	2	Solid wood	190	35	18
Insert	1	Centre choice	Centre choice	Centre choice	Centre choice

#### Carcass

Part	No	Material	Length(mm)	Breadth(mm)	Thickness(mm)
Front and back	2	Solid wood	250	90	16
Sides	2	Solid wood	190	90	16
Partition or internals	2	Solid wood	190	90	16
Tray supports	2	Solid wood	190	53	16
Base	1	Centre choice	250	190	3

#### Tray

Part	No	Material	Length(mm)	Breadth(mm)	Thickness(mm)
Sides and partition	1	Solid wood	930	30	12
Base	1	Centre choice	250	190	3

## Turnery

Part	No	Material	Length(mm)	Breadth(mm)	Thickness(mm)
Turned component	1	Solid wood	250	45	45

### Alteration or adaptation

You must not alter, adapt or modify the practical activity in any way. This includes moving the content into a different format or re-drawing and/or producing additional working drawings.

**You must not alter lengths or breadths** and you should not alter the thicknesses. However, if centres cannot source a material thickness, they can substitute for the closest available thickness. Any change to thickness must not impact on the validity of assessment. If a thickness is changed, you **must** amend the dimensions of the working drawings to reflect this change. The amended drawings must be in the identical format and layout to those issued by SQA.

# Questions and answers

**Q. My candidates are doing the course over two years, which practical activity do I give them?**

A. You must give them the practical activity for the same academic session as the question paper they are sitting. For example, a candidate sitting the question paper in May or June 2022 (whether as a one or two year delivery) would need to do the practical activity published in October 2021 (for use in session 2021-22).

**Q. Do I need to inform SQA if I am changing thicknesses?**

A. No. However, if selected for verification, you must let the verifier know when the visit is arranged so that they know what to expect.

**Q. I can't get lengths or breadths in the sizes noted, can I change them?**

A. No. This is a national assessment activity and consistency across all centres is essential. We want all candidates to be using the same length and breadth sizes to ensure that every candidate is doing the same assessment. Thicknesses are a special case, and you can only alter this by exception. If you cannot source the required materials and sizes, you need to escalate this within your centre, as your candidates will be unable to begin the practical activity.

**Q. Can I change the practical activity?**

A. No. You cannot change, reformat or add to the documentation related to the practical activity, as all candidates must do the same assessment. Likewise, you cannot give additional drawings to candidates. The only exception is when thicknesses have been changed and there is a consequential change to these dimensions.

**Q. Can the candidates produce something else?**

A. No. All candidates must do the practical activity for the current session. You cannot award marks for anything else.

**Q. What if I give candidates a practical activity from a previous session?**

A. You cannot award marks, as this is like giving candidates a past paper instead of the current live question paper. The practical activity documentation clearly states the academic session it is valid for. In addition, we remove older practical activity documentation from SQA's secure website after each academic session, so it is unlikely this would happen.

**Q. Can I substitute materials?**

A. No. You must use the materials stated in this document – if we state 'solid wood', then you cannot use manufactured board.

**Q. If I change a thickness, what is a suitable thickness?**

A. If you cannot find material in the given thickness, you must use material of the next available size. You should use your professional judgement to ensure that the assessment remains valid and candidates are not disadvantaged.

In addition, if you cannot source material in the given thickness, replacing it with something excessively thinner or thicker would not be appropriate. This would not allow the candidate to demonstrate their application of practical skills in a way that is consistent with candidates from other centres.



# Administrative information

---

Published: May 2024 (version 1.0)

---

## History of changes

Version	Description of change	Date

## Security and confidentiality

This document can be used by practitioners in SQA approved centres for the assessment of National Courses and not for any other purpose.

© Scottish Qualifications Authority 2024